

CJBX

Schallgedämmte Lüftungsanlagen mit Riemenantrieb



Ventilator:

- Lüftungsgeräte mit doppelseitig saugenden Ventilatoren der Serie CBX, CBXC und CBXR.
- Gehäuse aus verzinktem Stahlblech mit Wärme- und Schallsollierung.
- Gleichdruckturbine aus verzinktem Stahlblech.
- Stopfbüchse zur Kabeleinführung.

Motor:

- Motoren der Effizienzklasse IE3 für Leistungen $\geq 0,75$ kW, außer einphasige, 2 Drehzahlen und 8 Polen.
- Motoren der Effizienzklasse F mit Kugellager, Schutzart IP55.

- Drehstrommotor 230/400 V 50 Hz (bis 4 kW) und 400/690 V 50 Hz (für Leistungen über 4 kW).
- Betriebstemperatur: -25 °C ... $+60$ °C.

Ausführung:

- Verzinktem Stahlblech.

Auf Anfrage:

- Ausblasen mit rundem Querschnitt.
- ATEX-Zertifizierung.

Bestellnummer

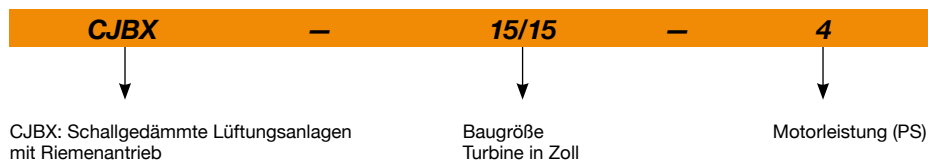

Technische Daten

Modell	Drehzahl (U/min)	Max. zulässiger Strom (A)			Installierte Leistung (kW)	Max. Luftvolumenstrom (m³/h)	Schalldruckpegel¹ dB (A) Abgestrahlt	Gewicht ca. (Kg)	Montagetyp
		230V	400V	690V					
CJBX-7/7-0.75	1600	2,17	1,25		0,55	1450	57	41	A
CJBX-7/7-1 IE3	1790	2,82	1,62		0,75	1500	59	43	A
CJBX-9/9-0.25	825	1,23	0,71		0,18	1700	46	48	A
CJBX-9/9-0.33	920	1,66	0,96		0,25	1800	48	50	A
CJBX-9/9-0.5	1020	2,02	1,17		0,37	2200	51	52	A
CJBX-9/9-0.75	1050	2,17	1,25		0,55	2900	55	55	A
CJBX-9/9-1 IE3	1070	2,82	1,62		0,75	3055	56	56	A
CJBX-9/9-1.5 IE3	1260	4,07	2,34		1,10	3600	60	59	A
CJBX-10/10-0.75	845	2,17	1,25		0,55	3800	56	57	A
CJBX-10/10-1 IE3	960	2,82	1,62		0,75	4175	59	59	A
CJBX-10/10-1.5 IE3	1070	4,07	2,34		1,10	4800	61	61	A
CJBX-10/10-2 IE3	1140	5,41	3,11		1,50	5400	64	65	A
CJBX-12/12-0.5	595	2,02	1,17		0,37	4200	53	69	A
CJBX-12/12-0.75	675	2,17	1,25		0,55	4800	56	71	A
CJBX-12/12-1 IE3	765	2,82	1,62		0,75	5400	59	72	A
CJBX-12/12-1.5 IE3	855	4,07	2,34		1,10	5800	60	75	A

Technische Daten

Modell	Drehzahl (U/min)	Max. zulässiger Strom (A)			Installierte Leistung (kW)	Max. Luftvolumenstrom (m ³ /h)	Schalldruckpegel ¹ dB (A) Abgestrahlt	Gewicht ca. (Kg)	Montagetyp
		230V	400V	690V					
CJBX-12/12-2 IE3	965	5,41	3,11		1,50	6500	63	79	A
CJBX-12/12-3 IE3	1180	7,93	4,56		2,20	7400	66	87	A
CJBX-15/15-0.75	525	2,17	1,25		0,55	5900	51	85	B
CJBX-15/15-1 IE3	595	2,82	1,62		0,75	6500	53	86	B
CJBX-15/15-1.5 IE3	635	4,07	2,34		1,10	7500	55	89	B
CJBX-15/15-2 IE3	670	5,41	3,11		1,50	8200	57	93	B
CJBX-15/15-3 IE3	740	7,93	4,56		2,20	9455	60	101	B
CJBX-15/15-4 IE3	805	10,70	6,15		3,00	10285	62	103	B
CJBX-18/18-1.5 IE3	480	4,07	2,34		1,10	9000	44	122	B
CJBX-18/18-2 IE3	605	5,41	3,11		1,50	9250	47	125	B
CJBX-18/18-3 IE3	590	7,93	4,56		2,20	11500	49	134	B
CJBX-18/18-4 IE3	640	10,70	6,15		3,00	13200	52	136	B
CJBX-18/18-5.5 IE3	675	13,90	8,00		4,00	15000	55	141	B
CJBX-18/18-7.5 IE3	760		10,30	5,97	5,50	17000	57	155	B
CJBX-20/20-2 IE3	430	5,41	3,11		1,50	11500	55	222	B
CJBX-20/20-3 IE3	530	7,93	4,56		2,20	12800	58	231	B
CJBX-20/20-4 IE3	575	10,70	6,15		3,00	14200	60	233	B
CJBX-20/20-5.5 IE3	635	13,90	8,00		4,00	15500	62	238	B
CJBX-20/20-7.5 IE3	675		10,30	5,97	5,50	17500	64	252	B
CJBX-20/20-10 IE3	725		13,90	8,06	7,50	20000	66	267	B
CJBX-22/22-2 IE3	385	5,41	3,11		1,50	14000	51	250	B
CJBX-22/22-3 IE3	475	7,93	4,56		2,20	15000	54	257	B
CJBX-22/22-4 IE3	515	10,70	6,15		3,00	17000	57	261	B
CJBX-22/22-5.5 IE3	570	13,90	8,00		4,00	19000	59	265	B
CJBX-22/22-7.5 IE3	605		10,30	5,97	5,50	21500	61	279	B
CJBX-22/22-10 IE3	725		13,90	8,06	7,50	22000	63	290	B
CJBX-22/22-15 IE3	765		20,90	12,10	11,00	27000	66	316	B
CJBX-25/25-3 IE3	375	7,93	4,56		2,20	17000	54	297	B
CJBX-25/25-4 IE3	405	10,70	6,15		3,00	20500	57	299	B
CJBX-25/25-5.5 IE3	450	13,90	8,00		4,00	22000	58	304	B
CJBX-25/25-7.5 IE3	485		10,30	5,97	5,50	24500	60	318	B
CJBX-25/25-10 IE3	545		13,90	8,06	7,50	28000	63	329	B
CJBX-25/25-15 IE3	610		20,90	12,10	11,00	32000	66	349	B
CJBX-30/28-3 IE3	280	7,93	4,56		2,20	20000	53	380	B
CJBX-30/28-4 IE3	310	10,70	6,15		3,00	22000	55	382	B
CJBX-30/28-5.5 IE3	340	13,90	8,00		4,00	25000	57	387	B
CJBX-30/28-7.5 IE3	380		10,30	5,97	5,50	31500	61	402	B
CJBX-30/28-10 IE3	410		13,90	8,06	7,50	36000	63	415	B
CJBX-30/28-15 IE3	430		20,90	12,10	11,00	42000	66	426	B
CJBX-30/28-20 IE3	480		27,90	16,20	15,00	48000	68	449	B

1. Die angegebenen Schalldruckpegel-Werte sind Drücke in dB(A), gemessen im Abstand von 3 m.



Erp. (Energy Related Products)

Informationen über die Richtlinie 2009/125/EG können auf der SODECA-Website oder den QuickFan-Selector heruntergeladen werden.

Abmessungen mm

Standardlieferung Horizontaler Druck
(H) LG 90

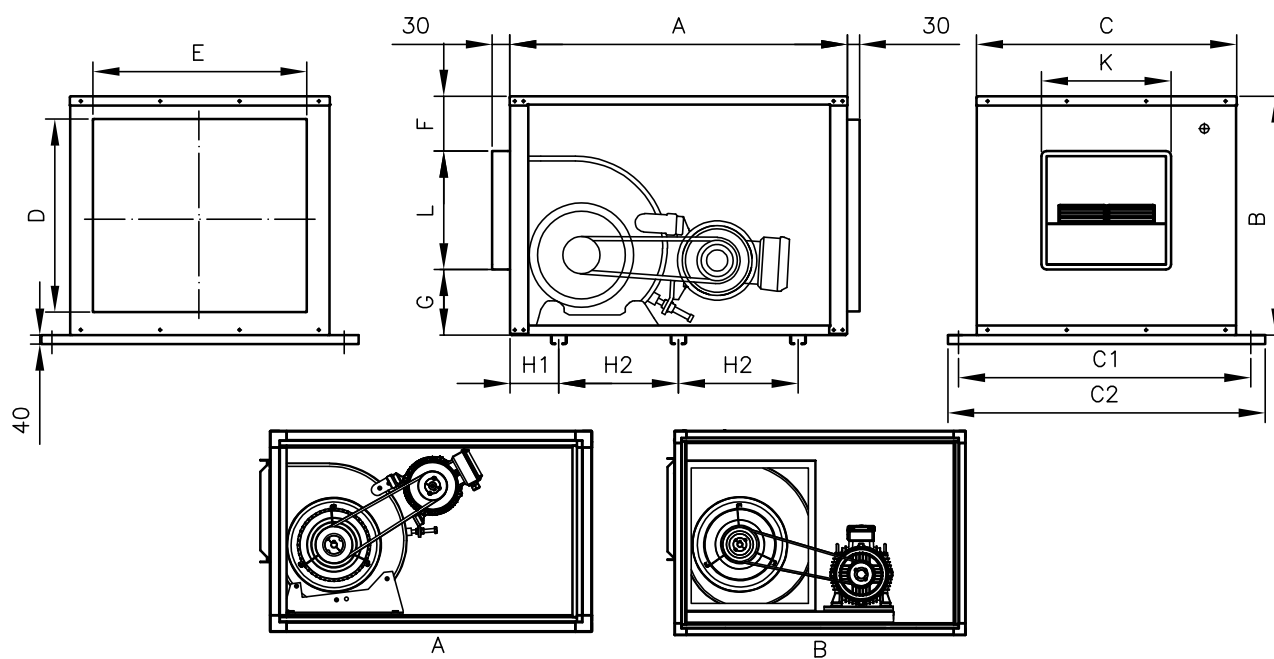

	A	B	C	C1	C2	D	E	F	G	H1	H2	K	L	Montagetyp
CJBX-7/7	650	460	500	-	-	370	410	107	128	-	-	250	228	A
CJBX-9/9	700	523	550	-	-	426	454	101	145	-	-	316	279	A
CJBX-10/10	750	575	600	-	-	483	508	100	170	-	-	342	308	A
CJBX-12/12	850	650	700	-	-	554	604	94	198	-	-	404	361	A
CJBX-15/15	1000	755	800	908	938	659	704	43	288	133	341	489	423	B
CJBX-18/18	1200	875	1000	1050	1080	779	903	35	338	117	460	556	502	B
CJBX-20/20	1400	1175	1100	1250	1280	1080	1005	157	398	94	588	622	622	B
CJBX-22/22	1460	1250	1250	1320	1350	1155	1155	136	401	80	648	672	712	B
CJBX-25/25	1632	1375	1450	1520	1550	1278	1354	148	413	78	738	782	815	B
CJBX-30/28	1800	1600	1650	1740	1770	1505	1555	139	527	83	808	906	956	B

Abmessungen mm

Auf Anfrage Vertikaldruck
(V) LG 0

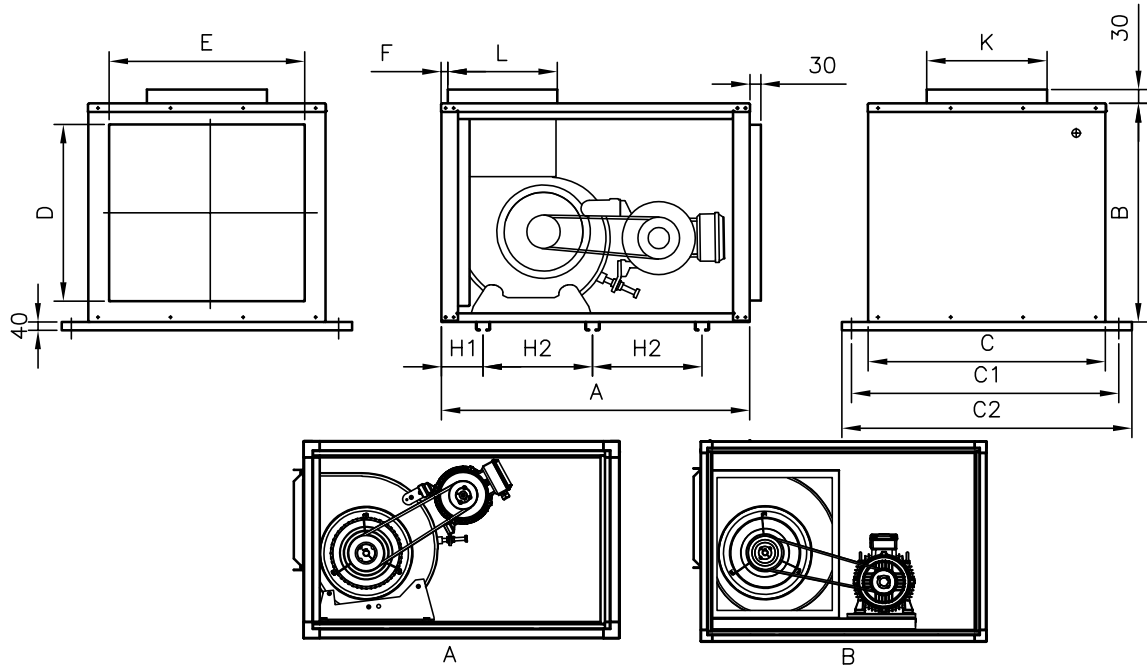

	A	B	C	C1	C2	D	E	F	H1	H2	K	L	Montagetyp
CJBX-7/7	650	460	500	-	-	370	410	14	-	-	253	230	A
CJBX-9/9	700	522	550	-	-	426	454	15	-	-	320	283	A
CJBX-10/10	750	575	600	-	-	483	508	21	-	-	346	312	A
CJBX-12/12	850	650	700	-	-	554	604	8	-	-	407	362	A
CJBX-15/15	1000	755	800	908	938	659	704	19	133	341	494	429	B
CJBX-18/18	1200	875	1000	1050	1080	779	903	30	117	460	561	507	B
CJBX-20/20	1400	1175	1100	1250	1280	1080	1005	55	94	588	626	626	B
CJBX-22/22	1460	1250	1250	1320	1350	1155	1155	61	80	648	677	718	B
CJBX-25/25	1630	1375	1450	1520	1550	1278	1354	66	78	738	786	818	B
CJBX-30/28	1800	1600	1650	1740	1770	1505	1555	45	83	808	910	959	B

Zubehör



INT



VSD3/A-RFT
- VSD1/A-RFM



AET



VIS



TEJ

Kennlinien

Q= Volumenstrom in m³/h, m³/s und cfm Pe= Statischer Druck in mmH₂O, Pa und inWG

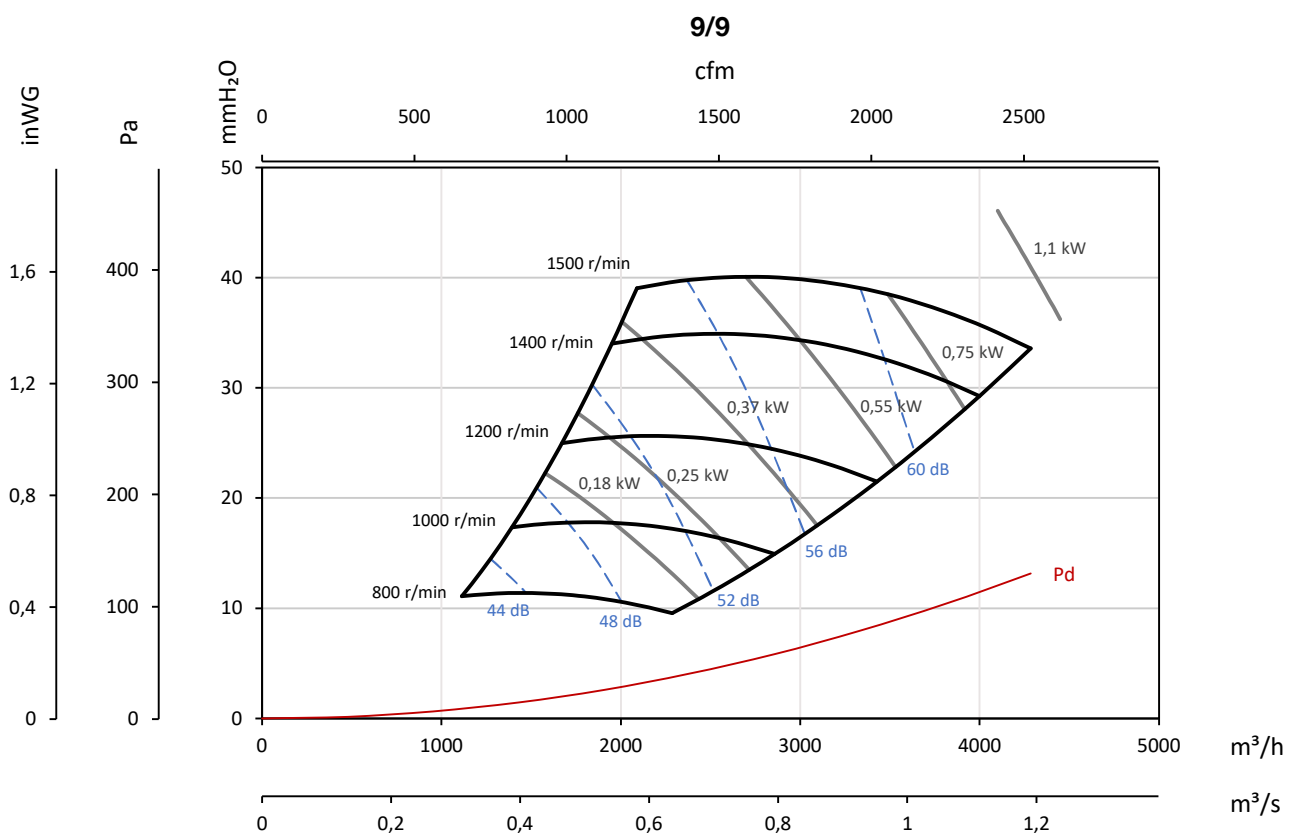
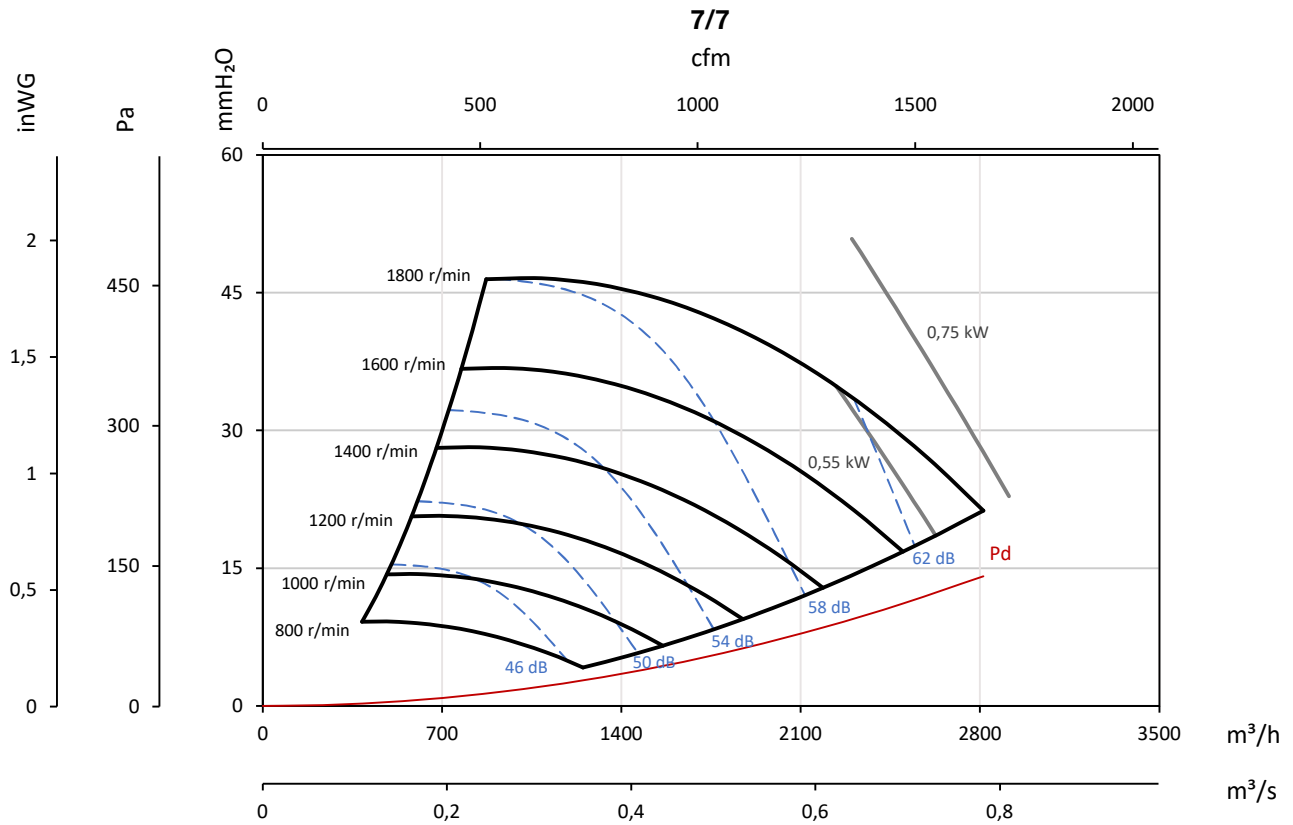

Kennlinien

Q= Volumenstrom in m³/h, m³/s und cfm Pe= Statischer Druck in mmH₂O, Pa und inWG

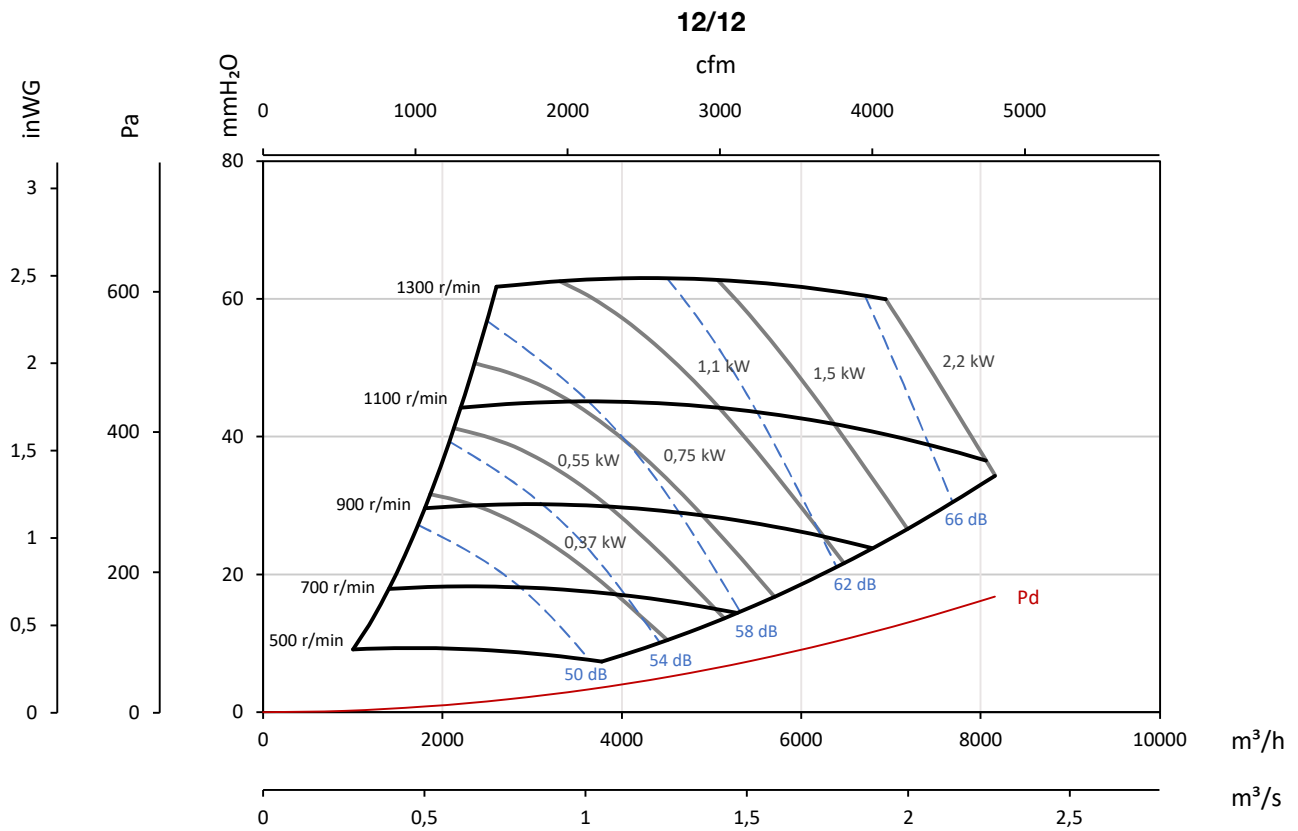
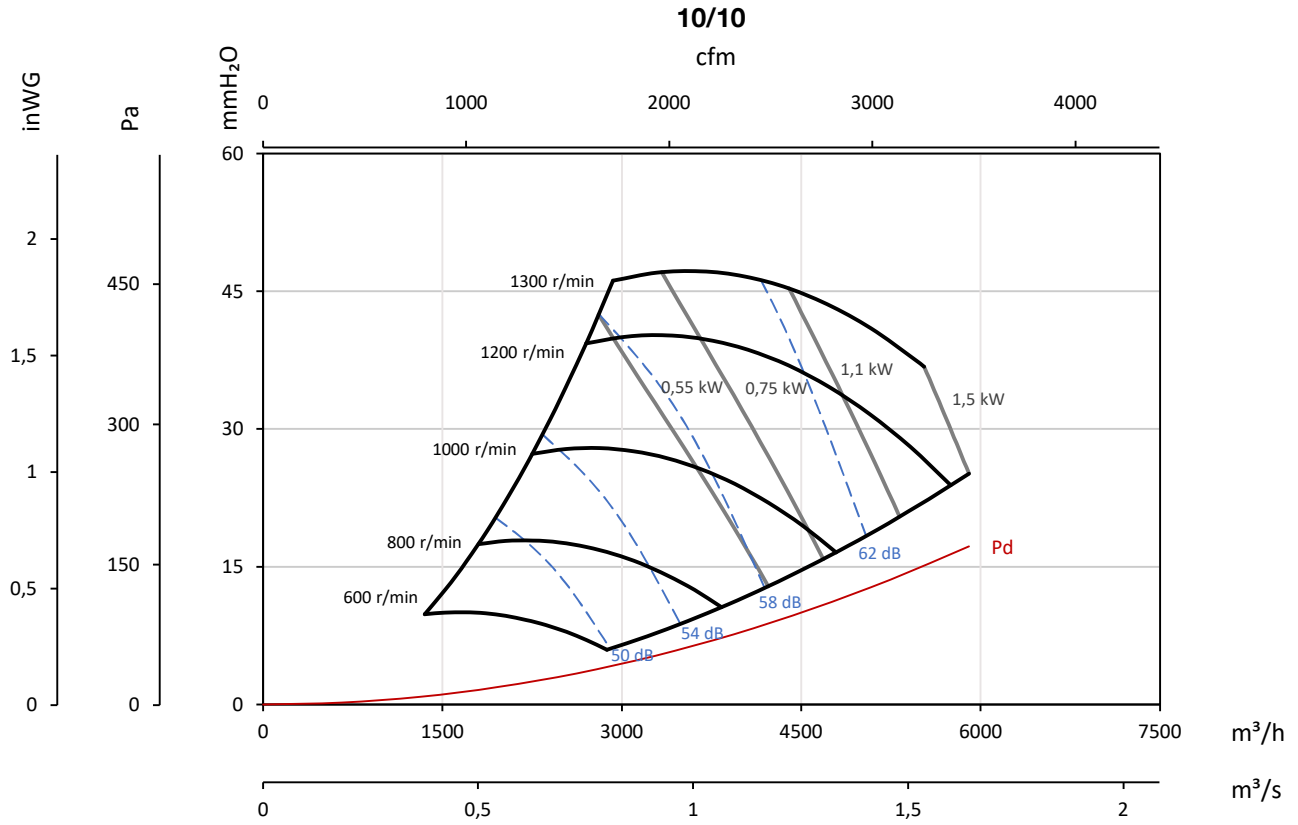

Kennlinien

Q= Volumenstrom in m³/h, m³/s und cfm Pe= Statischer Druck in mmH₂O, Pa und inwg

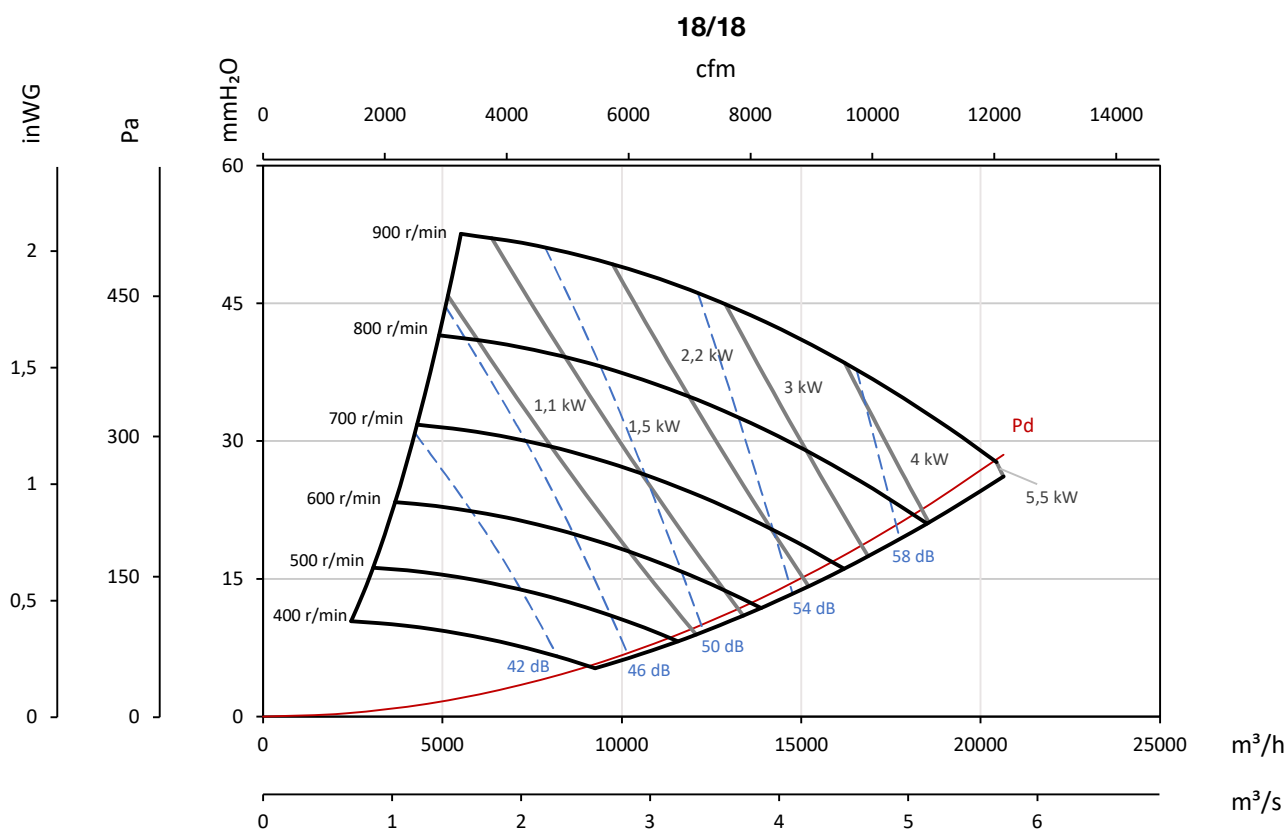
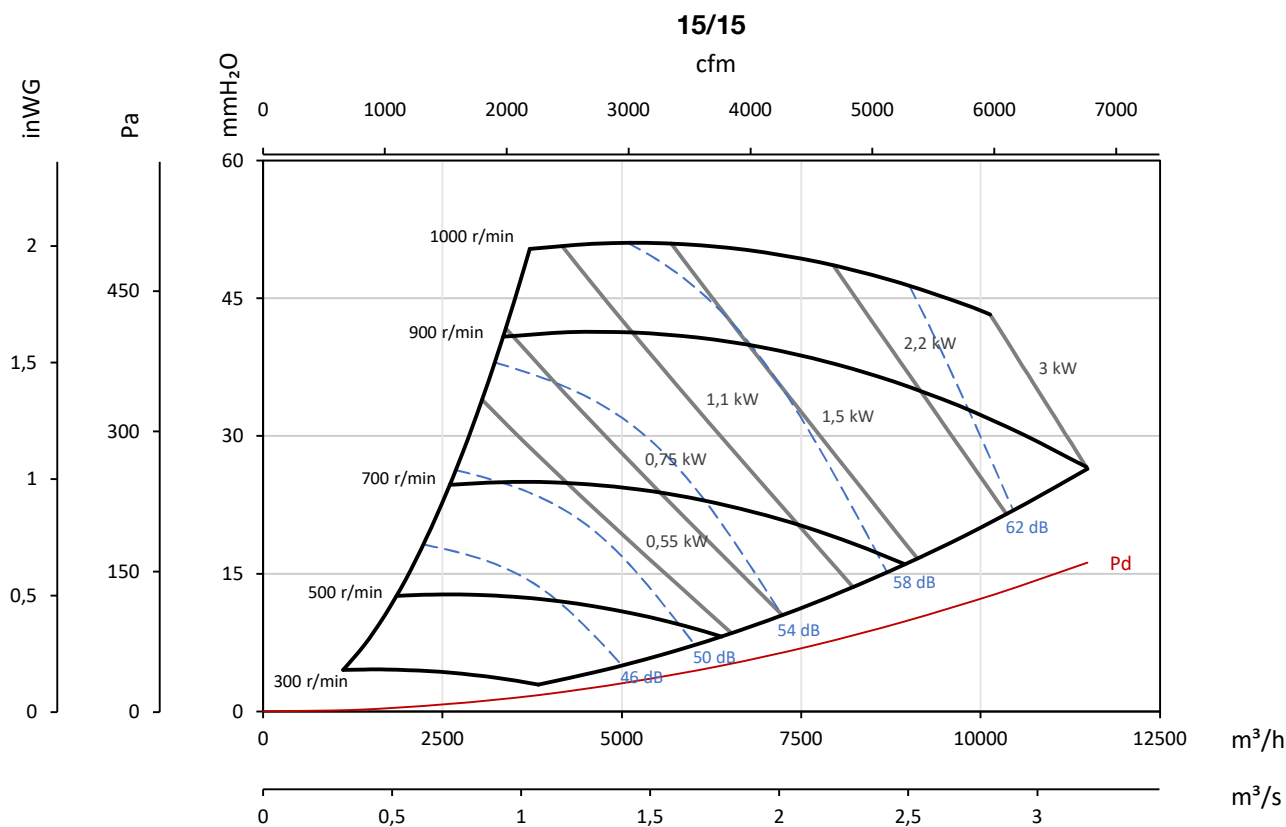

Kennlinien

Q= Volumenstrom in m³/h, m³/s und cfm Pe= Statischer Druck in mmH₂O, Pa und inWG

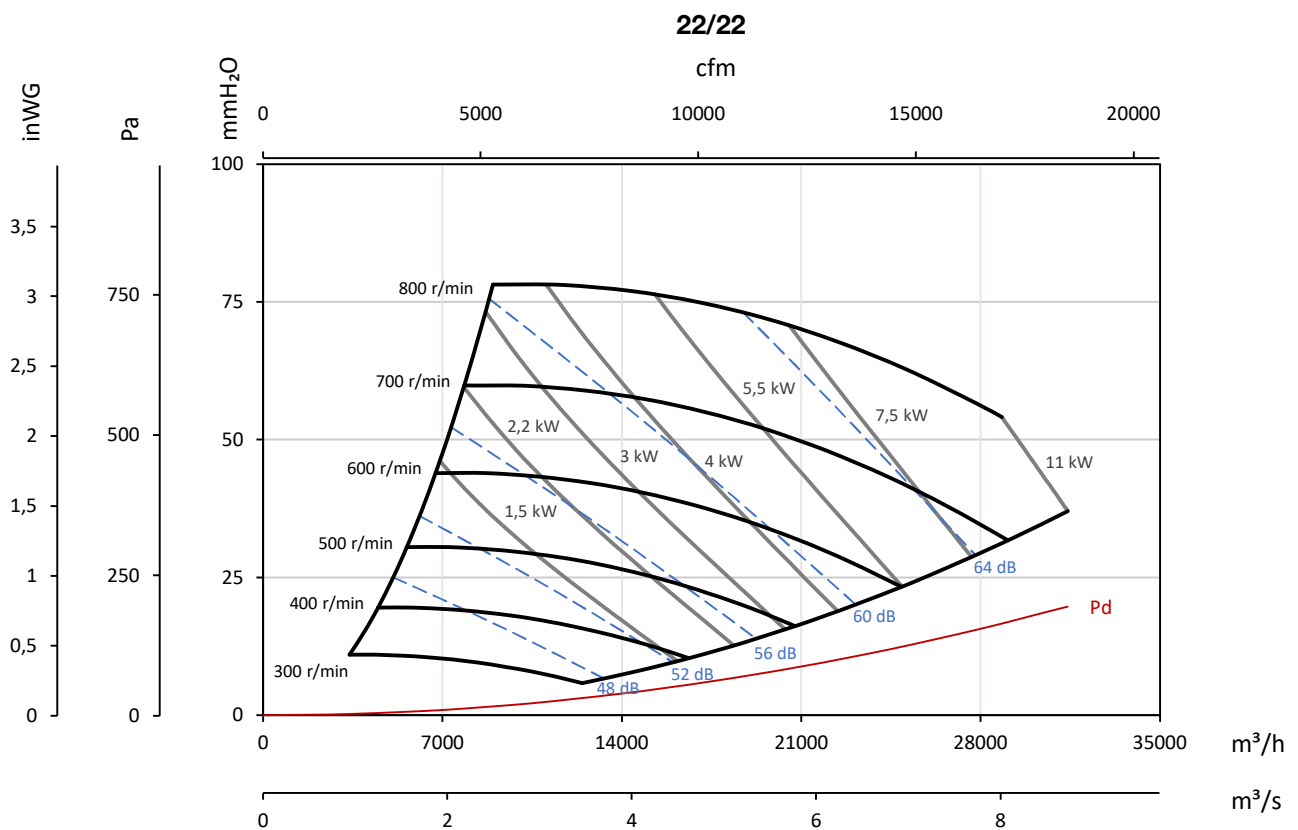
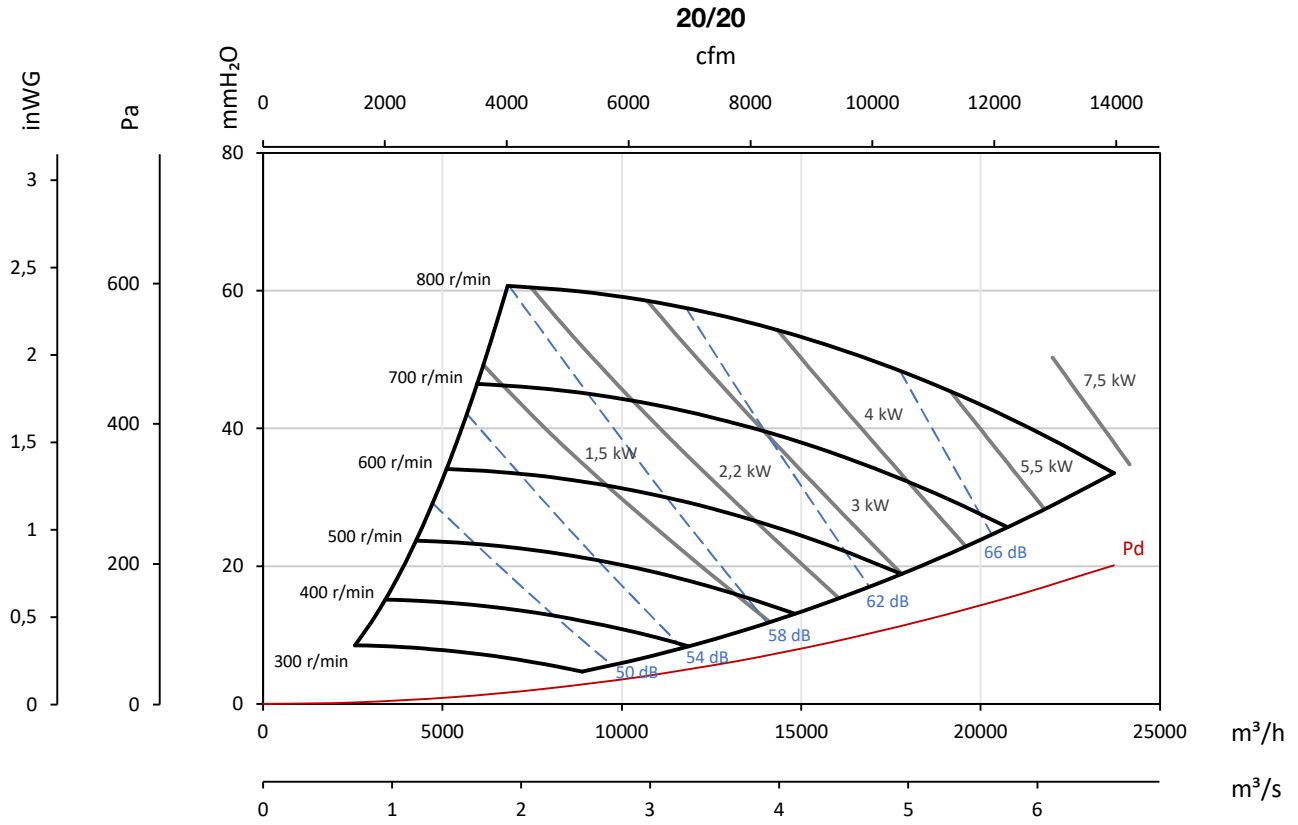

Kennlinien

Q= Volumenstrom in m³/h, m³/s und cfm Pe= Statischer Druck in mmH₂O, Pa und inwg

