

Ventilation Systems – Design and Calculations

AIR RENEWAL RATES FOR PREMISES IN GENERAL

recommended number of renewals/hour, depending on the type of premises (DIN 1946 standard)

Type of Premises renewals/h

Wardrobes	4-6
Laundries	10-20
Auditoria	6-8
Accumulator premises	5-10
Classrooms	5-7
Spray painting facilities	10-20
Libraries	4-5
Paint stripping facilities	5-15
Painting cabins	25-50
Offices	4-8
Strongrooms	3-6
Swimming pools	3-4
Cinemas, Theatres	5-8
Dipping baths	0-80
Domestic kitchens	15-25
Restaurants - Casinos	8-12
Commercial kitchens	15-30
Conference rooms	6-8
Bathrooms	5-7
Waiting rooms	4-6
Small meeting rooms	6-8
Photocopy rooms	10-15
Showers	12-25
Machine rooms	10-40
Foundries	8-15
Large meeting rooms	5-10
Garages	6
Workshops (high level of disturbance)	10-20
Gymnasia	4-6
Workshops (low level of disturbance)	3-6
Rooms	3-8
Assembly workshops	4-8
Domestic lavatory	4-5
Solder workshops	20-30
Public/industrial lavatory	8-15
Shops	4-8
Laboratories	8-15
Dry cleaners	5-15
Rolling mills	8-15
Changing rooms	6-8

CALCULATION OF AIRFLOWS IN FARMS

Recommended airflow per animal, depending on the type of rearing. (m³/h by rearing type)

Type	Age or Weight	Summer	Winter
Poultry fattening	Chicks 1-7 days old	1-3	0.1-0.2
Poultry fattening	Chicks 2-7 weeks old	5-8	0.2-0.3
Poultry fattening	Chicks over 7 weeks old	8-10	0.3-0.5
Hens for Laying	1 to 1.5 kg	8-10	0.3 -0.5
Hens for Laying	1 to 2 kg	9-12	0.3 -1

Hens for Laying	2 to 3 kg	12-15	0.5 -2
Laying hens	-	10-15	0.5-2
Piglets	5 kg	8	4
Piglets	10 kg	16	5
Piglets	15 kg	24	6
Piglets	20 kg	32	7
Piglets	25 kg	40	8
Pigs fattening	25 kg	30	4
Pigs fattening	30 kg	36	5
Pigs fattening	40 kg	48	6
Pigs fattening	50 kg	60	7
Pigs fattening	60 kg	72	9
Pigs fattening	70 kg	84	10
Pigs fattening	80 kg	96	11
Fattening pigs	90 Kg	108	13
Fattening pigs	100 kg	120	14
Sows	Weaner	180	17
Sows	to be inseminated	240	23
Sows	Pregnant	250	25
Sows with litter	Litter 10	375	28
Boars	-	360	36
Calves	3 weeks	50	5-10
Calves	2 weeks	100	10-25
Cattle fattening	-	150	15-50
Cows	-	175-200	40-60
Lambs fattening	20 to 25 Kg	90-100	10-15

ASSISTANCE WITH DUCT DESIGN

Design of Elbow Joints

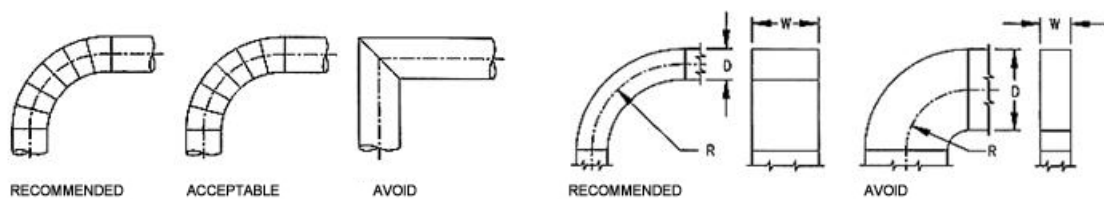

Elbow Radius: The elbow joints must have a radius of curvature of between 2 and 2.5 diameters, except when the available space does not allow this. (Recommended: average radius of curvature in the centre of 2 to 2.5 diameter / Acceptable: average radius of curvature in the centre of 1.5 diameter)

Size Ratio (W/D): The elbows must have W/D and R/D ratios greater than 1. Avoid "squared" right-angle elbow joints. If they are unavoidable, use them only with clean air and equip them with alert guidelines. Consult manufacturers about loss factors of elbows with alert guidelines.

Design of Ducts with Side Junctions

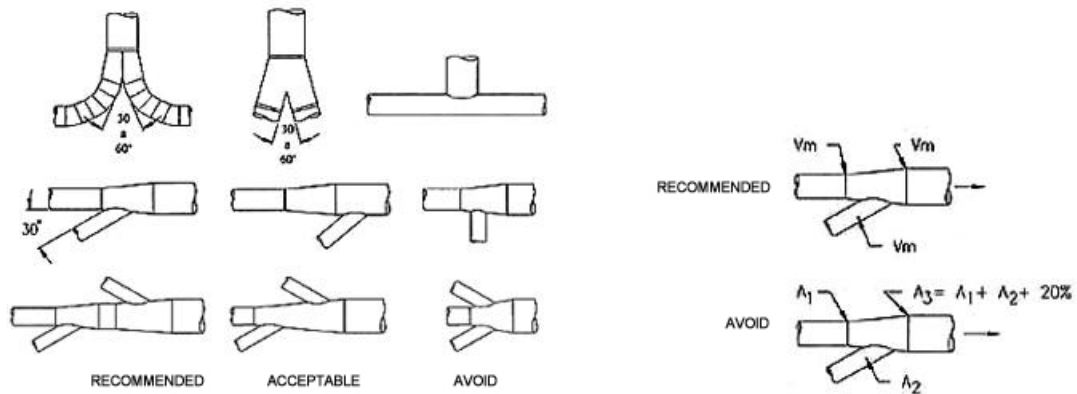

Side duct junctions: A side duct should join the main one at a tapered (progressive) widening and at an angle of 30° or less (recommended), or up to 45° or if there is insufficient space. The angle of the widening section must not be greater than 15°.

V_m : Minimum transport velocity

A: Duct cross-section

Correct duct size: Dimensions of the duct to maintain a velocity equal to or greater than the minimum transport velocity.

Design of fan inlet

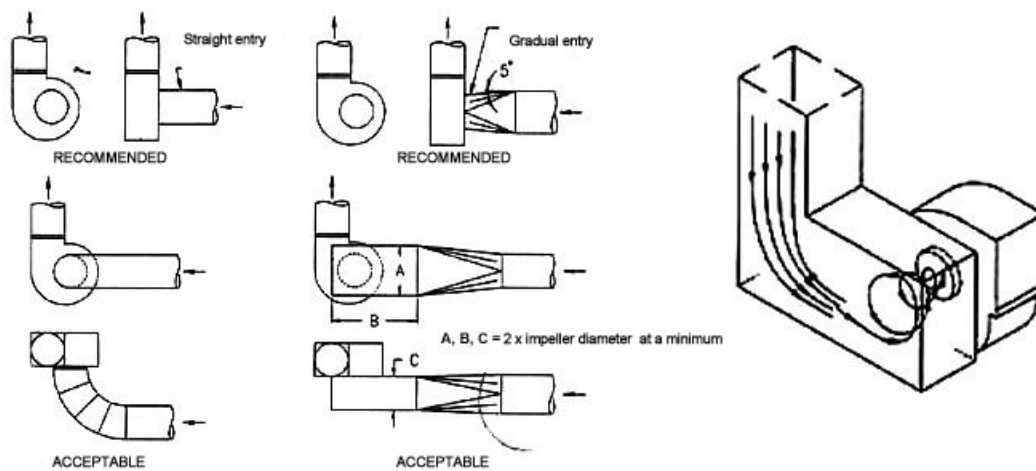

Use alert guidelines to avoid vortices in the air and an unbalanced load on the fan's impeller

Design of changes in duct cross-section

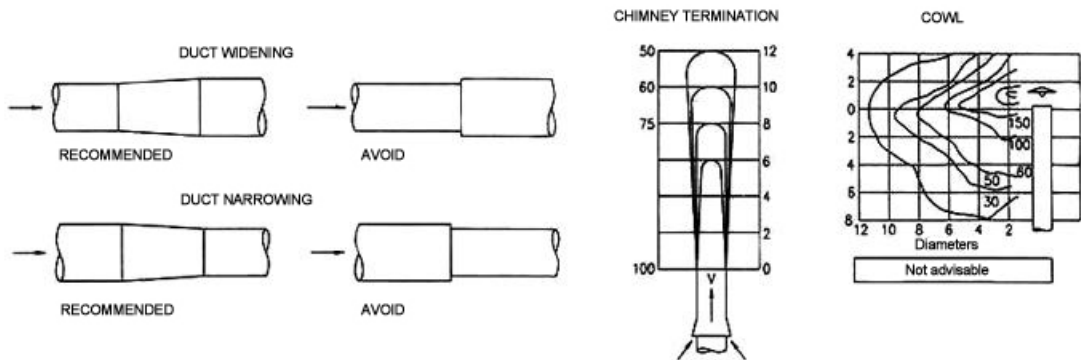

Design of chimney outlets

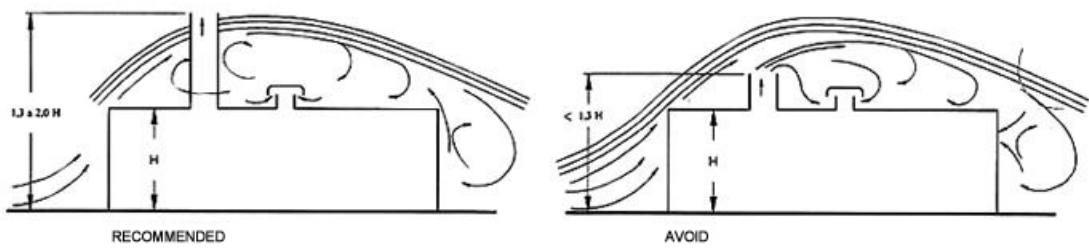

Recommended: chimney with discharge high in comparison with the height of the building, air inlets in the roof.
 Avoid: Chimney with discharge low with respect to the height of the building and the air inlets. Only applicable in the simple case of a low rise building without obstacles in the vicinity and on almost flat terrain.
 Note: A dip on the lee of the building (the opposite side to where the wind blows from) can cause pollutants to enter the building through any windows or air inlets in that area.

Types of suction hoods

DESCRIPTION	SLOT	LIPPED SLOT	LIPPED SIMPLE	FITTED CABIN	RAISED FITTED	LIPPED MULTIPLE	
WIL	0,2	0,2	0,20	0,2	0,2	0,2	
FLOW	3,7 LVX	2,6 LVX	$V(10X+A)$	$0,75V(10X+A)$	$VA-VMH$	$1,4 PVH$	$V(10X+A)$
							$0,75V(10X+A)$

Examples of optimal air entry into premises

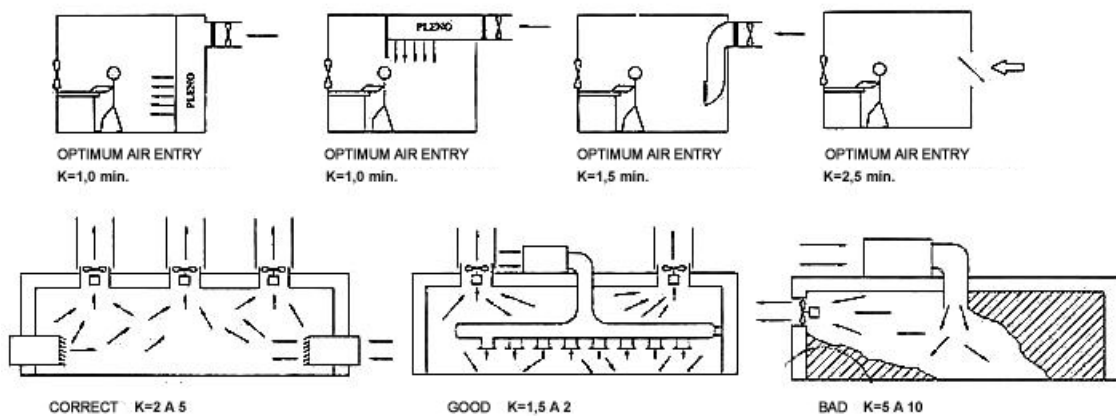

LOSS COEFFICIENTS IN DUCTS AND FITTINGS

These coefficients are used when calculating the loss of energy, using the dynamic pressure method. This method relies on the fact that all the energy losses due to friction in ducts and shape resistance due to separations in fittings are a function of the dynamic pressure, and can be calculated by multiplying the dynamic pressure by a frictional loss coefficient. To obtain the dynamic pressure, apply the following formula:

$$Pd = \left(\frac{V^2}{4,043} \right)$$

Where V is the velocity at which air flows in the duct.

Hood loss coefficients

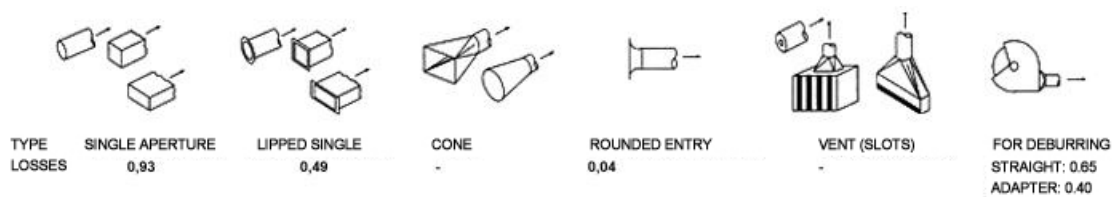

Inlet loss coefficients

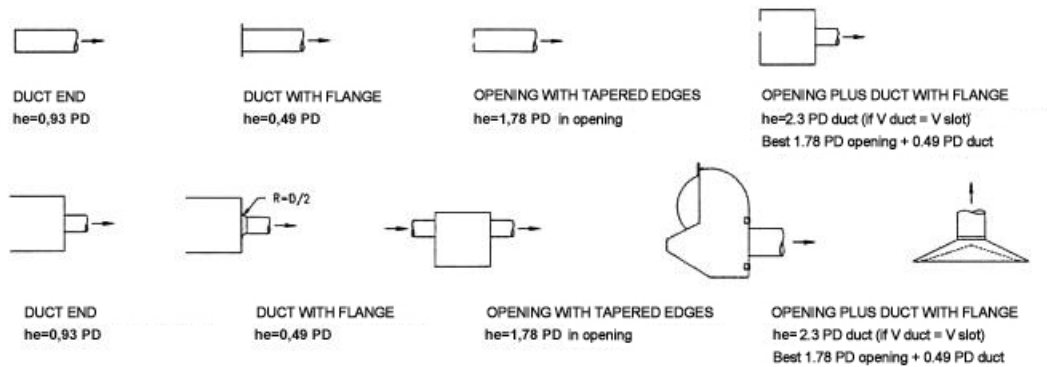

Reproduced with permission from "Industrial Health Engineering" by A.

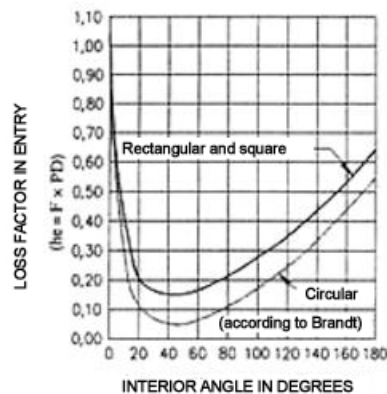

Open surface area at least twice the cross-section of the duct

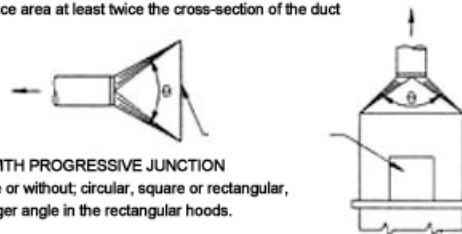

LOSS IN ENTRY	CIRCULAR	RECTANGULAR
15°	0,15 PD	0,25 PD
30°	0,08 PD	0,16 PD
45°	0,06 PD	0,15 PD
60°	0,08 PD	0,17 PD
90°	0,15 PD	0,25 PD
120°	0,26 PD	0,35 PD
150°	0,40 PD	0,48 PD

PD= Dynamic pressure in the duct
PE= Static pressure in the shaft, mm.w.c
he= Loss of energy in the entry, mm.w.c
Q = Airflow in m3/s
A= Cross-section of shaft in m2

Elbow loss coefficients

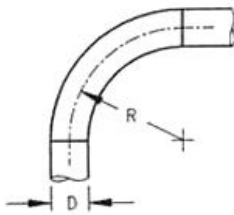

R/D	Loss of energy Fraction of PD
2,75	0,26
2,50	0,22
2,25	0,26
2,00	0,27
1,75	0,32
1,50	0,39
1,25	0,55

ELBOWS WITH CIRCULAR CROSS-SECTIONS.

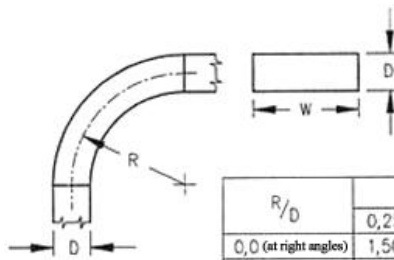

R/D	Size Ratio W/D					
	0,25	0,5	1,0	2,0	3,0	4,0
0,0 (at right angles)	1,50	1,32	1,15	1,04	0,92	0,86
0,5	1,36	1,21	1,05	0,95	0,84	0,79
1,0	0,45	0,28	0,21	0,21	0,20	0,19
1,5	0,28	0,18	0,13	0,13	0,12	0,12
2,0	0,24	0,15	0,11	0,11	0,10	0,10
3,0	0,24	0,15	0,11	0,11	0,10	0,10

ELBOWS WITH SQUARE AND RECTANGULAR CROSS-SECTIONS

Junction loss coefficients

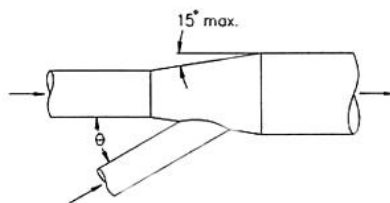

Note: The loss of energy occurs in the side duct and should be accounted for in it.

Do not include in the calculation the recovery of pressure in the side ducts with progressive joints.

0-degree angle	Loss of energy in side duct Fraction of PD
10	0,06
15	0,09
20	0,12
25	0,15
30	0,18
35	0,21
40	0,25
45	0,28
50	0,32
60	0,44
90	1,00

Chimney cowl loss coefficients

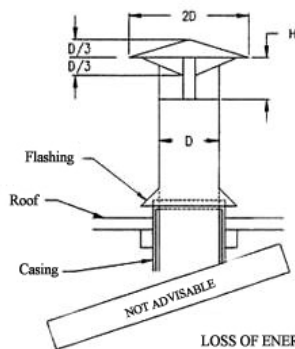

LOSS OF ENERGY IN COWLS

H, number of diameters	Loss of energy Fraction of PD
1,0 D	0,10
0,75 D	0,18
0,70 D	0,22
0,65 D	0,30
0,60 D	0,41
0,55 D	0,56
0,50 D	0,73
0,45 D	1,0

CAPTURE VELOCITIES

The capture velocity is the minimum air velocity (produced by the hood) required to capture the contaminated air and direct it toward the hood. The air speed achieved depends on the airflow sucked in and the area of the hood opening.

Contaminant dispersal conditions	Example	Capture velocity in m/s
Released at almost zero velocity into quiet air	Evaporation from tanks; degreasing, etc...	0.25-0.5
Released at low velocity into moderately still air	Spray booths, intermittent container filling, low speed conveyor belt transfers, welding, plating, passivation	0.05-1
Active generation into zone of very rapid air motion	Shallow spray painting booths, barrel filling, loading conveyors, crushers	1-2.5
Released at high velocity into zone of very rapid air motion	Grinding/deburring, abrasive blasting, demoulding in foundries	2.5-10

In each of the abovementioned conditions, a range of capture velocities is given. Selecting the appropriate value depends on the following factors

Lower limit	Upper Limit
<ul style="list-style-type: none"> Minimal air currents in the premises, favourable to contaminant capture Contaminants of low toxicity or merely annoying Low or intermittent production of contaminants Large hood or of large size or a large air mass in motion 	<ul style="list-style-type: none"> Disturbing air currents in the premises Highly toxic contaminants High production levels, continuous use Small hood, local control only

TRANSPORT VELOCITIES

The transport velocities of different materials depends on their size, density and the shape of the material (Dalla Valle)

6.1 Vertical upwards velocity:

$$V = 10.7 \frac{s}{s+1} \times d^{0,57}$$

6.2 Horizontal transport velocity:

$$V = 8,4 \frac{s}{s+1} \times d^{0,40}$$

V = Velocity, m/s

s = Material density

D = average diameter of the largest particle, mm.

6.3 Loss of energy due to mixture friction:

$$\frac{F_m}{F_a} = 1 + 0,32 \frac{W_s}{W_a}$$

F_m = Energy loss due to mixture friction

F_a = Loss of energy of air

W_s = Mass of solid

W_a = Mass of air

RECOMMENDED VELOCITIES FOR VENTILATION SYSTEMS

Function Type Public Buildings (m/s) Industrial Plants (m/s)

Air intake from outside	2.5-4.5	5-6
Air cleaners	2.5	2.5-3.0
Heater connection to fan	3.5-4.5	5-7
Main supply ducts	5.0-8.0	5-12
Risers and branch ducts	2.5-3.0	4.5-9.0
Supply registers and grilles	1.2 -2.3	-
Supply apertures	-	1.5-2.5
Supply grilles near the floor	0.8 -1.2	-
Vertical pipes	2.5-3.0	4.5-9.0
Main extract ducts	4.5-8.0	6-12

CYCLONE SEPARATORS

STANDARD MEASUREMENTS FOR CYCLONE SEPARATORS

CYCLONE SEPARATION FACTOR (S)

V = tangential velocity

r = Radius of the cyclone = $A/2$

g = Earth's gravitational acceleration

