

CJTHT

Ventilatori assiali 400 °C/2h e 300 °C/2h. Con scatola dotata di isolamento acustico



Unità di estrazione con ventilatori assiali per il funzionamento all'interno di zone a rischio incendio.

Ventilatore:

- Ventilatore con rivestimento tubolare in lamiera di acciaio.
- Struttura in lamiera di acciaio galvanizzato con isolamento termico e acustico.
- Eliche a inclinazione variabile in alluminio pressofuso.
- Omologazione secondo la norma EN 12101-3, con certificazioni n. 0370-CPR-0312 (F400) e 0370-CPR-0974 (F300).

Motore:

- Motori in classe H per uso continuo S1 e di emergenza S2. Con cuscinetti a sfere, grado di protezione IP55, a 1 o 2 velocità in base al modello.
- Motori di efficienza IE3 per potenze uguali o superiori a 0,75 kW, ad esclusione delle versioni monofase, 2 velocità e 8 poli.
- Trifase 230/400 V 50 Hz (fino a 3 kW) e 400/690 V 50 Hz (potenze superiori a 3 kW).

- Temperatura massima dell'aria da movimentare: Servizio S1 -25 °C +40 °C in continuo, adatto anche per climi caldi con temperature fino a 50 °C. Servizio S2 300 °C/2h, 400 °C/2h.

Finitura:

- Ventilatore: Anticorrosiva in resina di poliestere polimerizzata a 190 °C, previo sgrassaggio con trattamento nanotecnologico senza fosfati.
- Scatola: Anticorrosiva in lamiera di acciaio galvanizzato.

Versioni disponibili:

- CJTHT/ATEX: Ventilatori assiali con scatola dotata di isolamento acustico, con certificazioni ATEX, Categoria 3 Ex II3G per zona 2.
- CJTHT/PLUS: Ventilatori assiali con attenuatore acustico.

Su richiesta:

- Direzione aria girante-motore.
- Giranti totalmente reversibile.

Codice di ordinazione

Dalla dimensione 40 alla dimensione 100

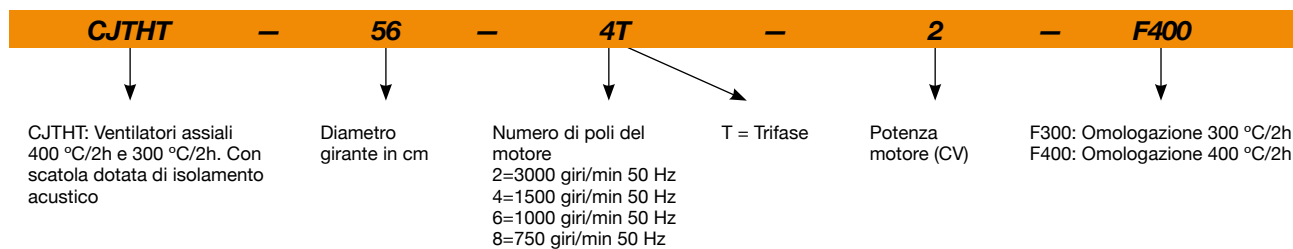

Dimensione 125

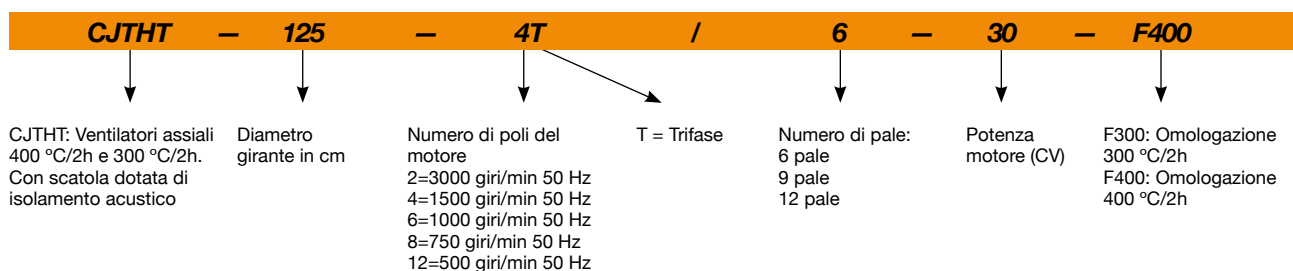

Caratteristiche tecniche

Modello	Velocità (giri/min)	Intensità massima consentita (A)			Potenza installata (kW)	Angolo di inclinazione delle pale (°)	Portata massima (m³/h)	Livello di pressione sonora¹ dB (A) Aspirazione	Peso circa (Kg)
		230V	400V	690V					
CJTHT-40-2/4T-1.5	2900 / 1435		2,89 / 1,04		1,10 / 0,25	20	7040 / 3480	71 / 56	50
CJTHT-40-4T-0.75	1420	2,84	1,64		0,55	32	4800	55	41
CJTHT-40-6T-0.75	930	2,90	1,75		0,55	32	3150	46	49
CJTHT-40-6/12T-0.75	940 / 455		2,35 / 1,15		0,60 / 0,15	32	3150 / 1520	46 / 31	53
CJTHT-45-2/4T-2	2940 / 1465		3,58 / 1,19		1,50 / 0,37	16	9400 / 4680	71 / 56	53
CJTHT-45-4T-0.75	1420	2,84	1,64		0,55	36	7450	58	43
CJTHT-45-6T-0.75	930	2,90	1,75		0,55	30	4450	48	51
CJTHT-45-6/12T-0.75	940 / 455		2,35 / 1,15		0,60 / 0,15	30	4450 / 2150	48 / 33	55
CJTHT-50-4T-0.75	1420	2,84	1,64		0,55	22	8390	60	48
CJTHT-50-6T-0.75	930	2,90	1,75		0,55	32	7000	52	52
CJTHT-56-4T-1 IE3	1430	3,08	1,79		0,75	22	11250	63	59
CJTHT-56-4T-1.5 IE3	1420	4,10	2,37		1,10	30	13600	63	61
CJTHT-56-4/8T-1.5	1440 / 705		2,69 / 1,12		1,10 / 0,25	30	13600 / 6640	63 / 48	65
CJTHT-56-4T-2 IE3	1425	5,89	3,38		1,50	36	15030	64	63
CJTHT-56-6T-0.75	930	2,90	1,75		0,55	38	10140	54	61
CJTHT-56-6/12T-0.75	940 / 455		2,35 / 1,15		0,60 / 0,15	38	10140 / 4890	54 / 39	65
CJTHT-63-4T-1 IE3	1430	3,08	1,79		0,75	14	15190	67	63
CJTHT-63-4T-1.5 IE3	1420	4,10	2,37		1,10	20	17800	66	66
CJTHT-63-4/8T-1.5	1440 / 705		2,69 / 1,12		1,10 / 0,25	20	17800 / 8680	66 / 51	69
CJTHT-63-4T-2 IE3	1425	5,89	3,38		1,50	24	19280	66	67
CJTHT-63-4/8T-2	1415 / 715		3,40 / 1,65		1,50 / 0,30	24	19280 / 9740	66 / 52	74
CJTHT-63-4T-3 IE3	1435	7,86	4,52		2,20	32	22150	68	73
CJTHT-63-4/8T-3	1415 / 700		4,80 / 1,85		2,20 / 0,45	32	22150 / 10920	68 / 53	87
CJTHT-63-4T-4 IE3	1430	11,01	6,33		3,00	38	24240	69	78
CJTHT-63-4/8T-4	1420 / 710		6,45 / 2,28		3,00 / 0,60	38	24240 / 12070	69 / 54	91
CJTHT-63-6T-0.75	930	2,90	1,75		0,55	28	13590	57	66
CJTHT-63-6/12T-0.75	940 / 455		2,35 / 1,15		0,60 / 0,15	28	13590 / 6550	57 / 42	69
CJTHT-63-6T-1 IE3	940	3,36	1,93		0,75	38	15890	58	67
CJTHT-63-6/12T-1	935 / 455		3,75 / 2,76		0,80 / 0,20	38	15890 / 7700	58 / 43	71
CJTHT-71-4T-1.5 IE3	1420	4,10	2,37		1,10	12	19480	71	82
CJTHT-71-4/8T-1.5	1440 / 705		2,69 / 1,12		1,10 / 0,25	12	19480 / 9500	71 / 56	86
CJTHT-71-4T-2 IE3	1425	5,89	3,38		1,50	14	20900	70	84
CJTHT-71-4/8T-2	1415 / 715		3,40 / 1,65		1,50 / 0,30	14	20900 / 10560	70 / 56	91
CJTHT-71-4T-3 IE3	1435	7,86	4,52		2,20	22	25100	70	90
CJTHT-71-4/8T-3	1415 / 700		4,80 / 1,85		2,20 / 0,45	22	25100 / 12370	70 / 55	103
CJTHT-71-4T-4 IE3	1430	11,01	6,33		3,00	28	27480	70	95
CJTHT-71-4/8T-4	1420 / 710		6,45 / 2,28		3,00 / 0,60	28	27480 / 13680	70 / 55	108
CJTHT-71-6T-0.75	930	2,90	1,75		0,55	20	16100	60	82
CJTHT-71-6/12T-0.75	940 / 455		2,35 / 1,15		0,60 / 0,15	20	16100 / 7760	60 / 45	86
CJTHT-71-6T-1 IE3	940	3,36	1,93		0,75	26	17300	60	84
CJTHT-71-6/12T-1	935 / 455		3,75 / 2,76		0,80 / 0,20	26	17300 / 8380	60 / 45	87
CJTHT-71-6T-1.5 IE3	945	4,73	2,72		1,10	34	19930	61	86
CJTHT-71-6/12T-1.5	940 / 460		3,52 / 2,00		1,20 / 0,30	34	19930 / 9760	61 / 46	97
CJTHT-80-4T-3 IE3	1435	7,86	4,52		2,20	12	25450	75	98
CJTHT-80-4/8T-3	1415 / 700		4,80 / 1,85		2,20 / 0,45	12	25450 / 12550	75 / 60	111
CJTHT-80-4T-4 IE3	1430	11,01	6,33		3,00	16	30250	74	103
CJTHT-80-4/8T-4	1420 / 710		6,45 / 2,28		3,00 / 0,60	16	30250 / 15060	74 / 59	115
CJTHT-80-4T-5.5 IE3	1440		7,95	4,61	4,00	18	32750	73	113
CJTHT-80-4/8T-5.5	1450 / 715		7,88 / 2,87		3,80 / 1,00	18	32750 / 16150	73 / 58	147
CJTHT-80-6T-1.5 IE3	945	4,73	2,72		1,10	18	21450	63	95
CJTHT-80-6/12T-1.5	940 / 460		3,52 / 2,00		1,20 / 0,30	18	21450 / 10500	63 / 48	105
CJTHT-80-6T-2 IE3	945	6,25	3,62		1,50	26	25950	64	99
CJTHT-80-6/12T-2	960 / 470		4,46 / 3,43		1,60 / 0,40	26	25950 / 12700	64 / 49	113
CJTHT-80-6T-3 IE3	950	9,78	5,62		2,20	32	29930	65	113

Caratteristiche tecniche

Modello	Velocità (giri/min)	Intensità massima consentita (A)			Potenza installata (kW)	Angolo di inclinazione delle pale (°)	Portata massima (m³/h)	Livello di pressione sonora¹ dB (A) Aspirazione	Peso circa (Kg)
		230V	400V	690V					
CJTHT-80-6/12T-3	940 / 475		5,62 / 3,32		2,20 / 0,55	32	29930 / 15120	65 / 51	118
CJTHT-80-8T-0.75	700	3,48	2,00		0,55	20	17540	57	99
CJTHT-80-8T-1	710	5,06	2,92		0,75	28	20650	58	111
CJTHT-90-4T-4 IE3	1430	11,01	6,33		3,00	8	33580	79	127
CJTHT-90-4/8T-4	1420 / 710		6,45 / 2,28		3,00 / 0,60	8	33580 / 16720	79 / 64	139
CJTHT-90-4T-5.5 IE3	1440		7,95	4,61	4,00	12	38890	78	137
CJTHT-90-4/8T-5.5	1450 / 715		7,88 / 2,87		3,80 / 1,00	12	38890 / 19170	78 / 63	171
CJTHT-90-4T-7.5 IE3	1430		10,40	6,04	5,50	18	46140	77	171
CJTHT-90-4/8T-7.5	1455 / 725		11,40 / 3,86		5,50 / 1,10	18	46140 / 22910	77 / 62	190
CJTHT-90-4T-10 IE3	1460		14,20	8,17	7,50	22	50140	76	208
CJTHT-90-4/8T-10	1455 / 725		15,10 / 5,16		7,50 / 1,50	22	50140 / 24900	76 / 61	198
CJTHT-90-6T-2 IE3	945	6,25	3,62		1,50	16	28780	66	123
CJTHT-90-6/12T-2	960 / 470		4,46 / 3,43		1,60 / 0,40	16	28780 / 14090	66 / 51	137
CJTHT-90-6T-3 IE3	950	9,78	5,62		2,20	24	34000	66	137
CJTHT-90-6/12T-3	940 / 475		5,62 / 3,32		2,20 / 0,55	24	34000 / 17180	66 / 52	142
CJTHT-90-6T-4 IE3	945	12,80	6,36		3,00	30	38900	69	171
CJTHT-90-6/12T-4	970 / 485		7,37 / 3,53		2,80 / 0,70	30	38900 / 19450	69 / 54	171
CJTHT-90-8T-1	710	5,06	2,92		0,75	18	22900	60	135
CJTHT-90-8T-2	700	7,32	4,21		1,50	30	29490	63	139
CJTHT-90-8T-3	705	9,30	5,35		2,20	32	30850	64	171
CJTHT-100-4T-7.5 IE3	1430		10,40	6,04	5,50	10	46850	82	179
CJTHT-100-4/8T-7.5	1455 / 725		11,40 / 3,86		5,50 / 1,10	10	46850 / 23260	82 / 67	198
CJTHT-100-4T-10 IE3	1460		14,20	8,17	7,50	16	57400	79	216
CJTHT-100-4/8T-10	1455 / 725		15,10 / 5,16		7,50 / 1,50	14	54710 / 27170	80 / 65	206
CJTHT-100-4T-15 IE3	1455		20,70	11,99	11,00	22	66300	79	251
CJTHT-100-4/8T-15	1470 / 730		20,70 / 7,19		11,00 / 3,00	22	66300 / 32880	79 / 64	251
CJTHT-100-4T-20 IE3	1460		27,80	16,03	15,00	28	76150	80	258
CJTHT-100-4/8T-20	1470 / 725		31,72 / 11,75		15,00 / 3,80	28	76150 / 37560	80 / 65	258
CJTHT-100-4T/9-15 IE3	1460		20,70	11,99	11,00	18	55340	80	260
CJTHT-100-4T/9-20 IE3	1460		27,80	16,03	15,00	22	63260	80	268
CJTHT-100-4T/9-25 IE3	1475		35,40	20,39	18,50	26	70620	80	308
CJTHT-100-4T/9-30 IE3	1475		42,20	24,44	22,00	30	74840	82	316
CJTHT-100-6T-3 IE3	950	9,78	5,62		2,20	16	37600	70	145
CJTHT-100-6/12T-3	940 / 475		5,62 / 3,32		2,20 / 0,55	16	37600 / 18990	70 / 56	150
CJTHT-100-6T-4 IE3	945	12,80	6,36		3,00	20	41150	69	179
CJTHT-100-6/12T-4	970 / 485		7,37 / 3,53		2,80 / 0,70	20	41150 / 20580	69 / 54	179
CJTHT-100-6T-5.5 IE3	970		8,37	4,82	4,00	26	47780	70	187
CJTHT-100-6T/9-5.5 IE3	970		11,00	6,35	4,00	20	39020	70	196
CJTHT-100-6T/9-7.5 IE3	970		12,30	7,07	5,50	26	46770	71	200
CJTHT-100-6T/9-10 IE3	970		15,20	8,83	7,50	34	52260	74	225
CJTHT-125-4T/6-20 IE3	1460		27,80	16,03	15,00	10	78600	87	466
CJTHT-125-4/8T/6-20	1470 / 725		31,72 / 11,75		15,00 / 3,80	10	78600 / 38770	87 / 72	485
CJTHT-125-4T/6-25 IE3	1465		35,40	20,39	18,50	14	92550	86	549
CJTHT-125-4/8T/6-27	1470 / 730		39,70 / 14,10		20,00 / 5,00	16	98830 / 48910	85 / 70	557
CJTHT-125-4T/6-30 IE3	1470		42,20	24,44	22,00	16	98830	85	554
CJTHT-125-4/8T/6-37	1475 / 735		54,55 / 18,50		28,00 / 6,50	20	110890 / 55260	85 / 70	633
CJTHT-125-4T/6-40 IE3	1475		53,30	31,02	30,00	22	117450	85	606
CJTHT-125-4T/6-50 IE3	1480		66,80	38,70	37,00	26	131050	85	734
CJTHT-125-4T/6-60 IE3	1475		80,90	46,90	45,00	28	135820	85	767
CJTHT-125-4T/6-75 IE3	1480		98,60	57,20	55,00	34	152100	88	848
CJTHT-125-4T/9-25 IE3	1465		35,40	20,39	18,50	10	79650	87	558
CJTHT-125-4T/9-30 IE3	1470		42,20	24,44	22,00	12	88290	86	563
CJTHT-125-4/8T/9-27	1470 / 730		39,70 / 14,10		20,00 / 5,00	12	88290 / 43690	86 / 71	566
CJTHT-125-4/8T/9-37	1475 / 735		54,55 / 18,50		28,00 / 6,50	16	104040 / 51840	85 / 70	642

Caratteristiche tecniche

Modello	Velocità (giri/min)	Intensità massima consentita (A)			Potenza installata (kW)	Angolo di inclinazione delle pale (°)	Portata massima (m³/h)	Livello di pressione sonora¹ dB (A) Aspirazione	Peso circa (Kg)
		230V	400V	690V					
CJTHT-125-4T/9-40 IE3	1475		53,30	31,02	30,00	16	104040	85	615
CJTHT-125-4T/9-50 IE3	1480		66,80	38,70	37,00	20	118400	85	743
CJTHT-125-4T/9-60 IE3	1475		80,90	46,90	45,00	24	134970	85	776
CJTHT-125-4T/9-75 IE3	1480		98,60	57,20	55,00	28	146770	86	857
CJTHT-125-4T/9-100 IE3	1480		128,00	74,22	75,00	34	158560	88	1018
CJTHT-125-4T/12-50 IE3	1480		66,80	38,70	37,00	18	101660	86	772
CJTHT-125-4T/12-60 IE3	1475		80,90	46,90	45,00	20	109180	86	785
CJTHT-125-4T/12-75 IE3	1480		98,60	57,20	55,00	26	131240	86	866
CJTHT-125-4T/12-100 IE3	1480		128,00	74,22	75,00	32	154100	88	1036
CJTHT-125-6T/6-5.5 IE3	970		8,37	4,82	4,00	10	51500	77	402
CJTHT-125-6T/6-7.5 IE3	970		12,30	7,07	5,50	14	60640	75	410
CJTHT-125-6/12T/6-7.5	970 / 480		14,50 / 5,17		5,50 / 1,00	14	60640 / 30010	75 / 60	454
CJTHT-125-6T/6-10 IE3	960		15,20	8,83	7,50	20	72650	74	458
CJTHT-125-6/12T/6-10	970 / 490		13,60 / 5,69		7,20 / 1,80	20	72650 / 36510	74 / 60	466
CJTHT-125-6T/6-15 IE3	955		22,50	13,07	11,00	26	85850	74	475
CJTHT-125-6/12T/6-15	970 / 485		23,10 / 8,41		11,00 / 3,00	26	85850 / 42710	74 / 59	566
CJTHT-125-6T/6-20 IE3	950		29,00	16,78	15,00	30	92850	76	542
CJTHT-125-6/12T/6-24	970 / 480		41,60 / 13,21		17,60 / 2,85	34	99650 / 49320	78 / 63	631
CJTHT-125-6T/9-10 IE3	960		15,20	8,83	7,50	14	63490	77	467
CJTHT-125-6/12T/9-10	970 / 490		13,60 / 5,69		7,20 / 1,80	14	63490 / 31910	77 / 63	475
CJTHT-125-6T/9-15 IE3	955		22,50	13,07	11,00	20	77550	75	484
CJTHT-125-6/12T/9-15	970 / 485		23,10 / 8,41		11,00 / 3,00	20	77550 / 38580	75 / 60	575
CJTHT-125-6T/9-20 IE3	950		29,00	16,78	15,00	26	92950	75	551
CJTHT-125-6/12T/9-24	970 / 480		41,60 / 13,21		17,60 / 2,85	30	98500 / 48750	76 / 61	640
CJTHT-125-6T/9-25 IE3	975		36,10	20,77	18,50	32	101450	77	627
CJTHT-125-6T/9-30 IE3	975		42,30	24,35	22,00	36	106520	80	638
CJTHT-125-6T/12-10 IE3	970		15,20	8,83	7,50	12	49630	79	496
CJTHT-125-6T/12-15 IE3	970		22,50	13,07	11,00	18	67310	77	513
CJTHT-125-6T/12-20 IE3	970		29,00	16,78	15,00	24	81840	76	580
CJTHT-125-6T/12-25 IE3	975		36,10	20,77	18,50	30	96770	77	656
CJTHT-125-6T/12-30 IE3	975		42,30	24,35	22,00	32	102040	78	667
CJTHT-125-6T/12-40 IE3	985		56,00	32,50	30,00	34	106350	79	782

1 I valori dei livelli di rumore sono pressioni in dB(A), misurate in campo libero a una distanza di 3 metri.



Erp. (Energy Related Products)

Informazioni sulla direttiva 2009/125/CE scaricabili dal sito web di SODECA o da QuickFan Selector.

Caratteristiche acustiche

Spettro di potenza sonora Lw(A) in dB(A) per banda di frequenza in Hz
Valori presi in aspirazione con portata massima

	63	125	250	500	1000	2000	4000	8000		63	125	250	500	1000	2000	4000	8000
40-2-1.5	47	63	75	83	88	86	82	75	50-4-0.75	49	61	69	75	75	75	70	62
40-4-1.5 (2V)	32	48	60	68	73	71	67	60	50-6-0.75	41	53	61	67	67	67	62	54
40-4-0.75	37	53	63	70	71	68	67	68	56-4-1	51	63	72	78	78	78	72	64
40-6-0.75	28	44	54	61	62	59	58	59	56-4-1.5	51	63	72	78	78	78	72	64
40-12-0.75 (2V)	12	28	38	45	46	43	42	43	56-8-1.5 (2V)	35	47	56	62	62	62	56	48
45-2-2	47	60	74	86	87	86	82	74	56-4-2	52	64	73	79	79	79	73	65
45-4-2 (2V)	32	45	59	71	72	71	67	59	56-6-0.75	45	55	65	69	70	68	61	53
45-4-0.75	47	59	67	73	73	73	68	60	56-12-0.75 (2V)	29	39	49	53	54	52	45	37
45-6-0.75	37	49	57	63	63	63	58	50	63-4-1	48	64	76	82	84	81	74	66
45-12-0.75 (2V)	21	33	41	47	47	47	42	34	63-4-1.5	47	63	75	81	83	80	73	65

Caratteristiche acustiche

Spettro di potenza sonora Lw(A) in dB(A) per banda di frequenza in Hz
Valori presi in aspirazione con portata massima

	63	125	250	500	1000	2000	4000	8000		63	125	250	500	1000	2000	4000	8000
63-8-1.5 (2V)	31	47	59	65	67	64	57	49	100-4/9-15	65	81	88	95	96	94	90	82
63-4-2	54	66	75	81	81	81	75	67	100-4/9-20	72	84	88	94	95	95	92	84
63-8-2 (2V)	39	51	60	66	66	66	60	52	100-4/9-25	72	84	88	94	95	95	92	84
63-4-3	56	68	77	83	83	83	77	69	100-4/9-30	74	86	90	96	97	97	94	86
63-8-3 (2V)	41	53	62	68	68	68	62	54	100-6-3	57	72	82	85	86	83	75	67
63-4-4	57	69	78	84	84	84	78	70	100-12-3 (2V)	42	57	67	70	71	68	60	52
63-8-4 (2V)	42	54	63	69	69	69	63	55	100-6-4	56	71	81	84	85	82	74	66
63-6-0.75	48	58	68	72	73	71	64	56	100-12-4 (2V)	41	56	66	69	70	67	59	51
63-12-0.75 (2V)	32	42	52	56	57	55	48	40	100-6-5.5	57	72	82	85	86	83	75	67
63-6-1	49	59	69	73	74	72	65	57	100-6/9-5.5	57	72	82	85	86	83	75	67
63-12-1 (2V)	32	42	52	56	57	55	48	40	100-6/9-7.5	58	73	83	86	87	84	76	68
71-4-1.5	57	73	80	86	86	86	82	74	100-6/9-10	61	76	86	89	90	87	79	71
71-8-1.5 (2V)	41	57	64	70	70	70	66	58	125-4/6-20	69	85	96	103	104	102	95	87
71-4-2	56	72	79	85	85	85	81	73	125-8/6-20 (2V)	54	70	81	88	89	87	80	72
71-8-2 (2V)	41	57	64	70	70	70	66	58	125-4/6-25	68	84	95	102	103	101	94	86
71-4-3	56	72	79	85	85	85	81	73	125-4/6-27	67	83	94	101	102	100	93	85
71-8-3 (2V)	41	57	64	70	70	70	66	58	125-8/6-27 (2V)	52	68	79	86	87	85	78	70
71-4-4	63	75	79	85	85	86	83	75	125-4/6-30	67	83	94	101	102	100	93	85
71-8-4 (2V)	48	60	64	70	70	71	68	60	125-4/6-37	67	83	94	101	102	100	93	85
71-6-0.75	46	53	73	76	76	71	63	55	125-8/6-37 (2V)	52	68	79	86	87	85	78	70
71-12-0.75 (2V)	30	37	57	60	60	55	47	39	125-4/6-40	67	83	94	101	102	100	93	85
71-6-1	46	64	73	76	76	71	64	55	125-4/6-50	67	83	94	101	102	100	93	85
71-12-1 (2V)	29	47	56	59	59	54	47	38	125-4/6-60	67	83	94	101	102	100	93	85
71-6-1.5	47	65	74	77	77	72	65	56	125-4/6-75	70	86	97	104	105	103	96	88
71-12-1.5 (2V)	32	50	59	62	62	57	50	41	125-4/9-25	67	81	94	102	104	101	96	88
80-4-3	55	71	84	91	91	88	82	74	125-4/9-27	66	80	93	101	103	100	95	87
80-8-3 (2V)	40	56	69	76	76	73	67	59	125-8/9-27 (2V)	51	65	78	86	88	85	80	72
80-4-4	54	70	83	90	90	87	81	73	125-4/9-30	66	80	93	101	103	100	95	87
80-8-4 (2V)	39	55	68	75	75	72	66	58	125-4/9-37	65	79	92	100	102	99	94	86
80-4-5.5	53	69	82	89	89	86	80	72	125-8/9-37 (2V)	50	64	77	85	87	84	79	71
80-8-5.5 (2V)	38	54	67	74	74	71	65	57	125-4/9-40	65	79	92	100	102	99	94	86
80-6-1.5	53	68	75	78	79	76	70	62	125-4/9-50	65	79	92	100	102	99	94	86
80-12-1.5 (2V)	38	53	60	63	64	61	55	47	125-4/9-60	73	86	95	99	101	100	96	89
80-6-2	59	69	75	79	80	78	73	65	125-4/9-75	74	87	96	100	102	101	97	90
80-12-2 (2V)	43	53	59	63	64	62	57	49	125-4/9-100	76	89	98	102	104	103	99	92
80-6-3	60	70	76	80	81	79	74	66	125-4/12-50	66	80	93	101	103	100	95	87
80-12-3 (2V)	45	55	61	65	66	64	59	51	125-4/12-60	66	80	93	101	103	100	95	87
80-8-0.75	46	59	67	72	74	71	64	53	125-4/12-75	74	87	96	100	102	101	97	90
80-8-1	47	60	68	73	75	72	65	54	125-4/12-100	76	89	98	102	104	103	99	92
90-4-4	61	77	88	94	95	93	88	80	125-6/6-5.5	64	79	89	92	93	90	85	77
90-8-4 (2V)	46	62	73	79	80	78	73	65	125-6/6-7.5	62	77	87	90	91	88	83	75
90-4-5.5	60	76	87	93	94	92	87	79	125-12/6-7.5 (2V)	47	62	72	75	76	73	68	60
90-8-5.5 (2V)	45	61	72	78	79	77	72	64	125-6/6-10	61	76	86	89	90	87	82	74
90-4-7.5	59	75	86	92	93	91	86	78	125-12/6-10 (2V)	46	61	71	74	75	72	67	59
90-8-7.5 (2V)	44	60	71	77	78	76	71	63	125-6/6-15	61	76	86	89	90	87	82	74
90-4-10	58	74	85	91	92	90	85	77	125-12/6-15 (2V)	45	60	70	73	74	71	66	58
90-8-10 (2V)	43	59	70	76	77	75	70	62	125-6/6-20	63	78	88	91	92	89	84	76
90-6-2	52	67	78	82	82	78	71	63	125-6/6-24	65	80	90	93	94	91	86	78
90-12-2 (2V)	36	51	62	66	66	62	55	47	125-12/6-24 (2V)	50	65	75	78	79	76	71	63
90-6-3	52	67	78	82	82	78	71	63	125-6/9-10	61	76	87	93	94	88	84	77
90-12-3 (2V)	37	52	63	67	67	63	56	48	125-12/9-10 (2V)	46	61	72	78	79	73	69	62
90-6-4	60	70	80	85	85	82	76	68	125-6/9-15	59	74	85	91	92	86	82	75
90-12-4 (2V)	45	55	65	70	70	67	61	53	125-12/9-15 (2V)	43	58	69	75	76	70	66	59
90-8-1	42	63	70	75	78	74	67	56	125-6/9-20	59	74	85	91	92	86	82	75
90-8-2	51	66	73	78	81	77	70	59	125-6/9-24	60	75	86	92	93	87	83	76
90-8-3	53	67	74	79	82	78	71	60	125-12/9-24 (2V)	45	60	71	77	78	72	68	61
100-4-7.5	67	83	90	97	98	96	92	84	125-6/9-25	61	76	87	93	94	88	84	77
100-8-7.5 (2V)	52	68	75	82	83	81	77	69	125-6/9-30	64	79	90	96	97	91	87	80
100-4-10	65	81	88	95	96	94	90	82	125-6/12-10	63	78	89	95	96	90	86	79
100-8-10 (2V)	50	66	73	80	81	79	75	67	125-6/12-15	61	76	87	93	94	88	84	77
100-4-15	71	83	87	93	94	94	91	83	125-6/12-20	60	75	86	92	93	87	83	76
100-8-15 (2V)	56	68	72	78	79	79	76	68	125-6/12-25	61	76	87	93	94	88	84	77
100-4-20	72	84	88	94	95	95	92	84	125-6/12-30	62	77	88	94	95	89	85	78
100-8-20 (2V)	57	69	73	79	80	80	77	69	125-6/12-40	63	78	89	95	96	90	86	79

Dimensioni in mm

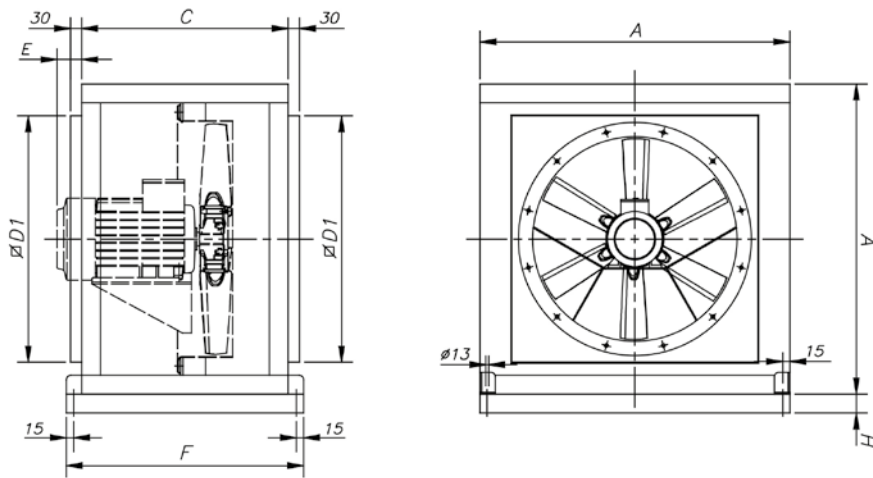

	A	C	ØD1	E	F	H
CJTHT-40/45/50	700	550	565	-	630	-
CJTHT-56/63	825	550	690	140	630	-
CJTHT-71/80	1000	650	850	-	730	-
CJTHT-90/100	1200	750	1050	-	830	-
CJTHT-125 ≤20 CV	1600	1200	1400	-	1280	-
CJTHT-125 >20 CV	1600	1200	1400	123	1280	100

Accessori



INT



IAT



CABLE BOX



C2V



VSD3/A-RFT
- VSD1/A-RFM



CENTRAL CO



AET



P-400



BOXPARK

Configurazione con BOXPARK



Quadri di controllo per sistemi di ventilazione di autorimesse con triple obiettivo: ventilazione giornaliera, controllo di CO ed estrazione di fumo in caso d'incendio

Quadri di controllo in cassa involucro metallico con tutti gli elementi necessari per la gestione e controllo dei ventilatori di sistemi di ventilazione di autorimesse, che siano basati su reti di condotti o ventilatori ad impulsi, per il controllo dei livelli di concentrazione di CO e l'estrazione di fumo in caso d'incendio. Quadri adattati a tutte le potenze e numeri di ventilatori secondo le necessità del progetto.

Per ulteriori informazioni, guardare serie BOXPARK.

Esempi di installazione con BOXPARK

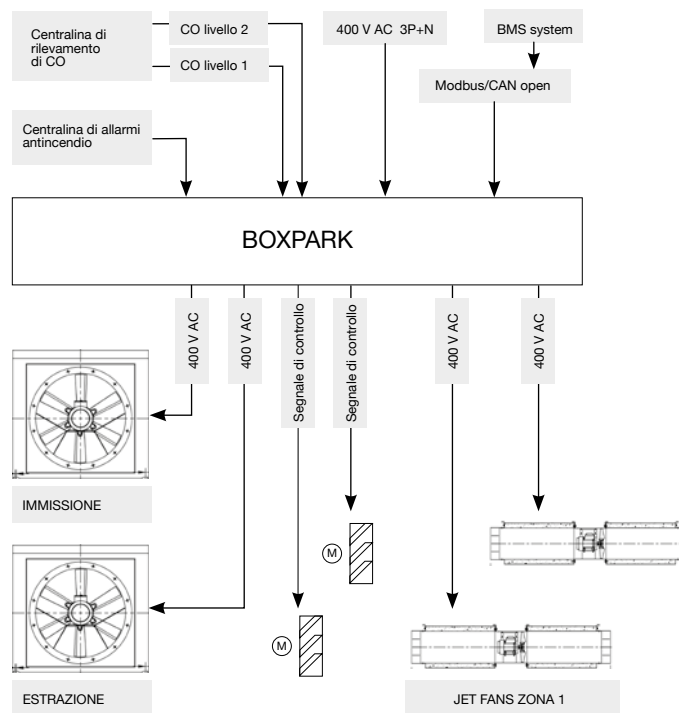

ESEMPIO SELEZIONE

Curve caratteristiche

Q= Portata in m³/h, m³/s e cfm

Pe= Pressione statica in mmH₂O, Pa e inwg

Diametro girante in cm: 71

Numero di poli del motore: 6

Numero di pale: 6

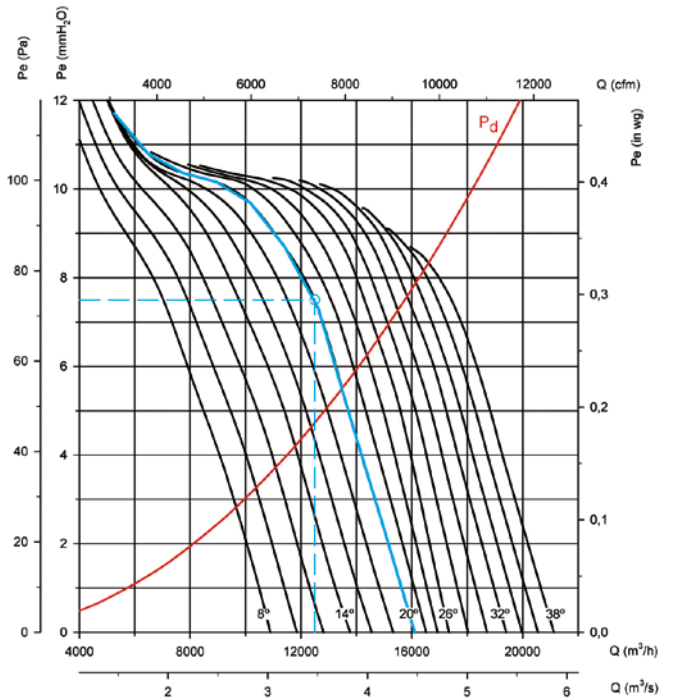

Dati di partenza

Punto di lavoro:

- Portata: 12.500 m³/h
- Perdita di carico: 7,5 mmH₂O

Tappe per la selezione del ventilatore

Nella grafica delle pressioni:

- Marcare il punto di lavoro, definito dalla portata di lavoro (12.500 m³/h) e la perdita di carico (7,5 mmH₂O).
- Scegliere la curva del ventilatore che più si avvicina al di sopra del punto di lavoro. Nel nostro caso si ottiene una curva di 20° di angolo di pala.

Nella grafica di potenza:

- Marcare il punto di lavoro, definito dalla portata di lavoro (12.500 m³/h) e la curva di pala scelto (20°).
- Leggere la potenza assorbita nell'asse di potenze sulla sinistra. La Pa= 510 W nel punto di lavoro.
- Cercare la linea rossa che più si avvicina alla parte superiore del punto di lavoro. Nella parte destra della grafica si ottiene il valore di potenza installata di motore. Nel nostro caso 0,55 kW o 0,75 CV.

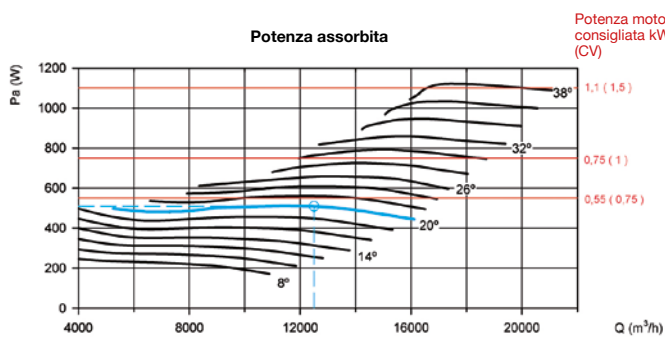

ESEMPIO CODICE ORDINE

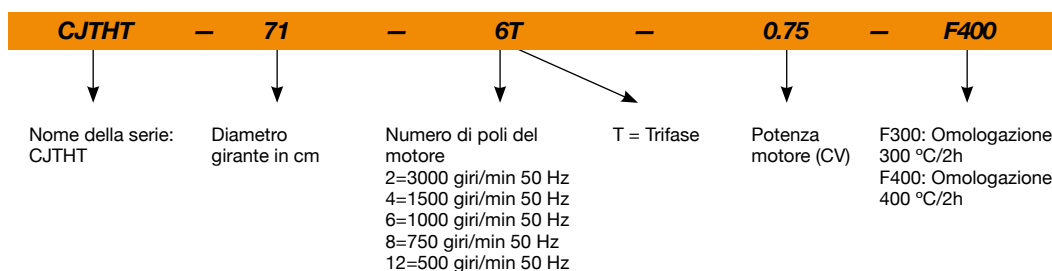

Curve caratteristiche

Q= Portata in m³/h, m³/s e cfm

Pe= Pressione statica in mmH₂O, Pa e inwg

Diametro girante in cm: 40

Numero di poli del motore: 2

Numero di pale: 6

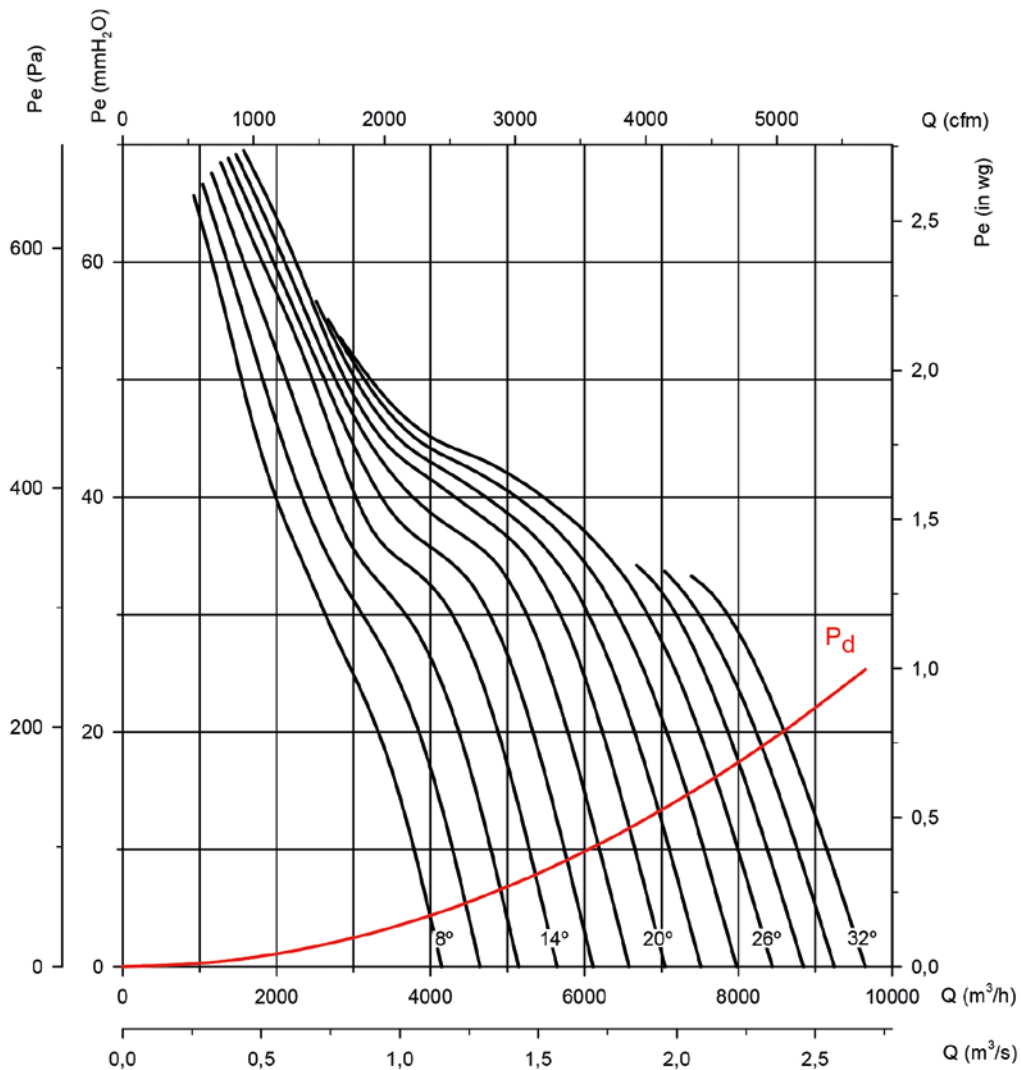

Potenza assorbita

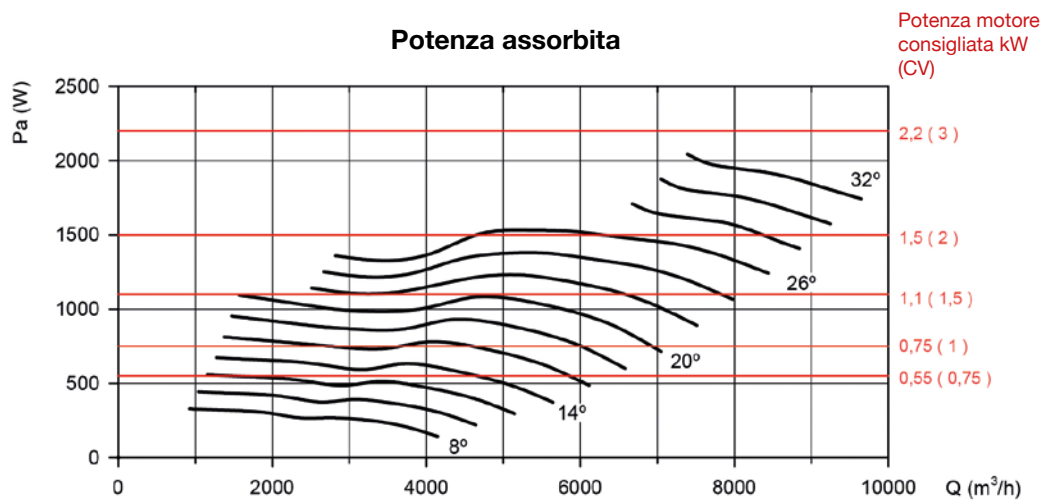

Curve caratteristiche

Q= Portata in m³/h, m³/s e cfm

Pe= Pressione statica in mmH₂O, Pa e inwg

Diametro girante in cm: 40

Numero di poli del motore: 4

Numero di pale: 6

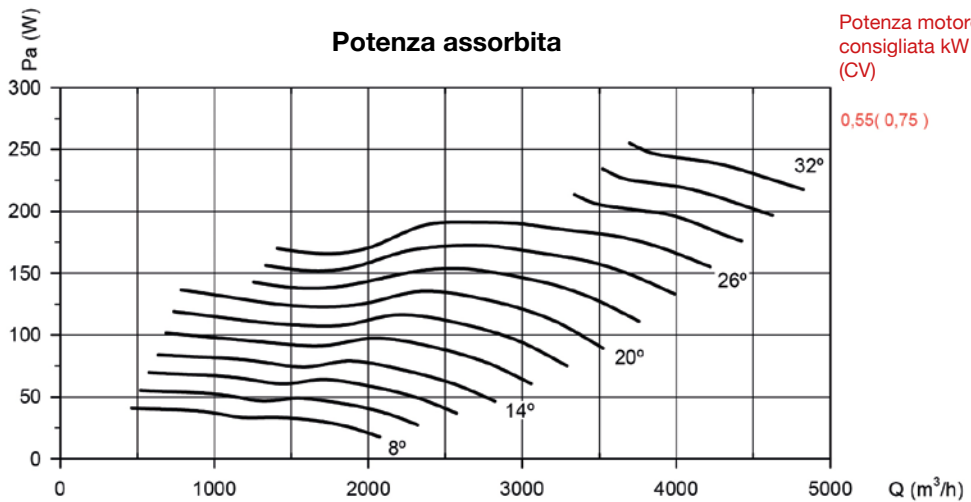
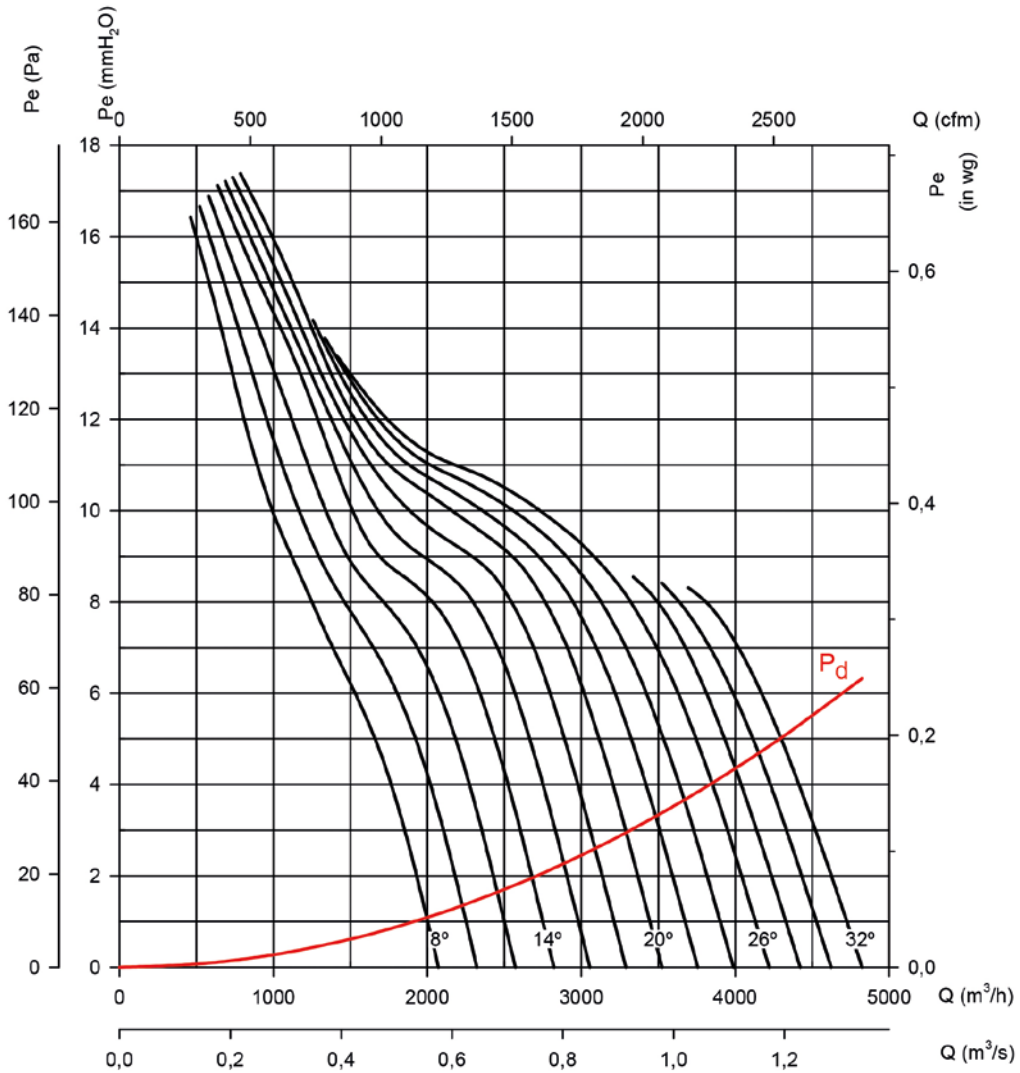

Curve caratteristiche

Q= Portata in m³/h, m³/s e cfm

Pe= Pressione statica in mmH₂O, Pa e inwg

Diametro girante in cm: 40

Numero di poli del motore: 6

Numero di pale: 6

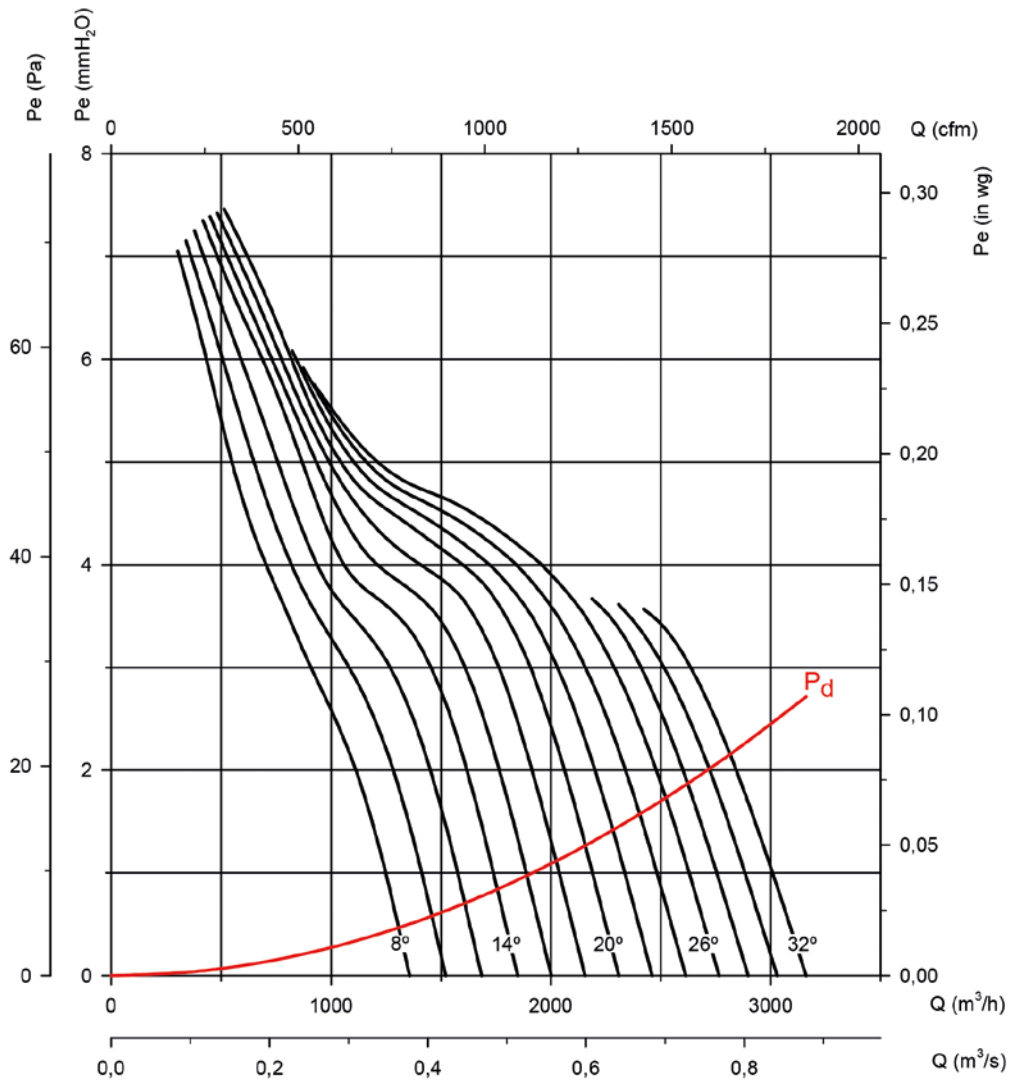

Potenza assorbita

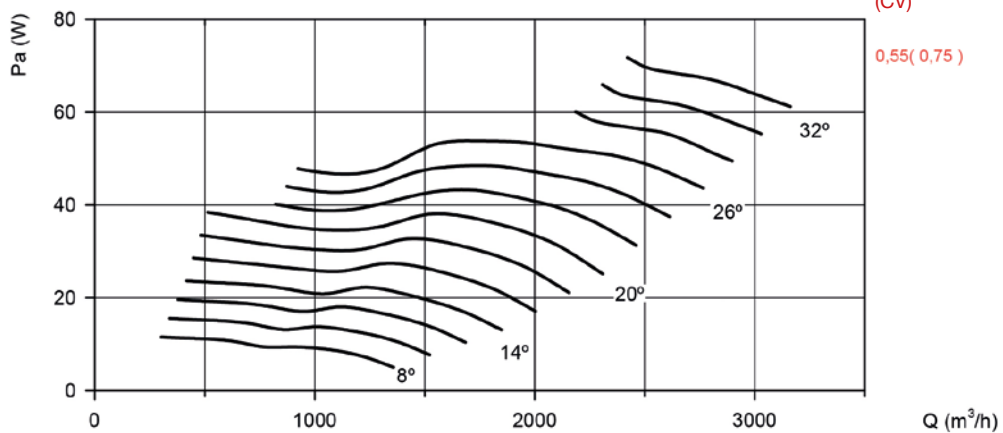

Potenza motore
consigliata kW
(CV)

0,55(0,75)

Curve caratteristiche

Q= Portata in m³/h, m³/s e cfm

Pe= Pressione statica in mmH₂O, Pa e inwg

Diametro girante in cm: 45

Numero di poli del motore: 2

Numero di pale: 6

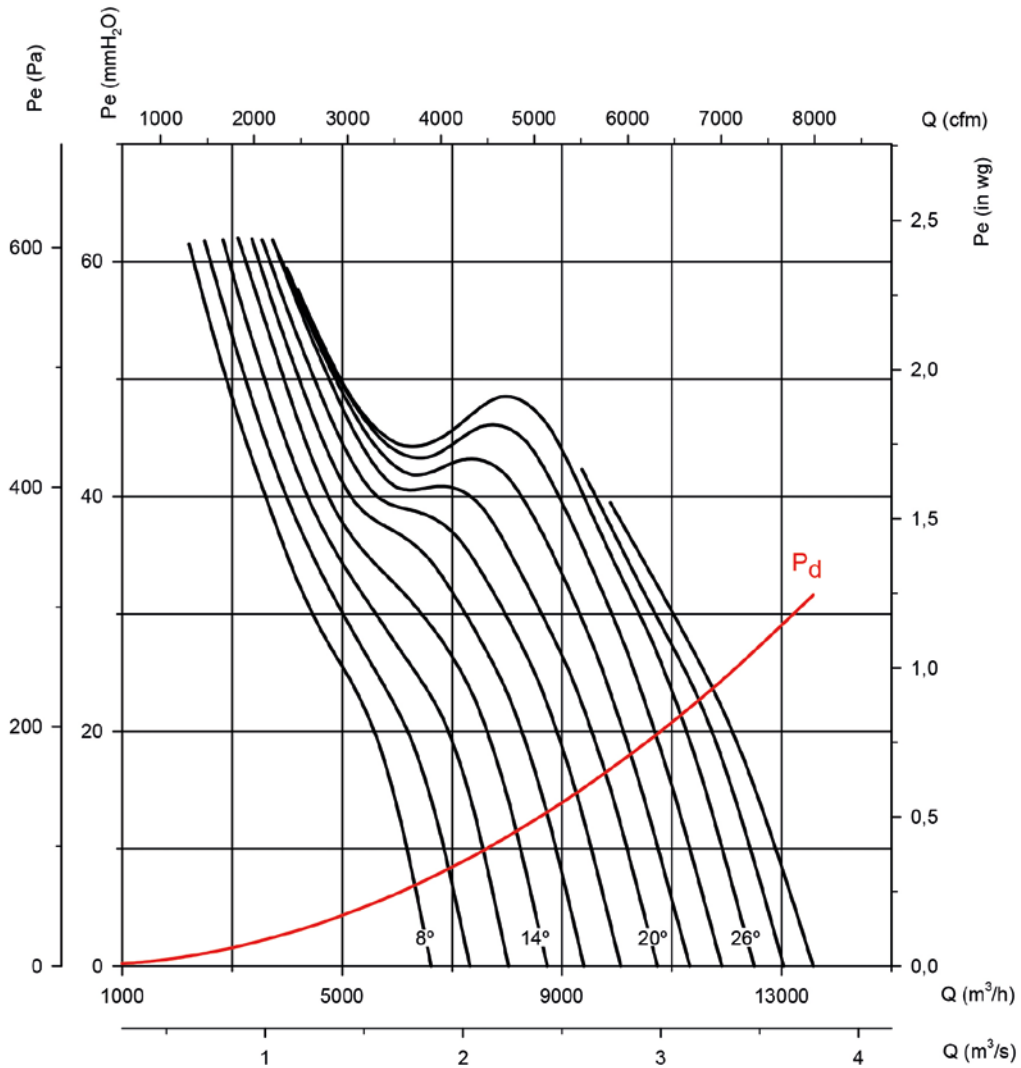

Potenza assorbita

Potenza motore
consigliata kW
(CV)

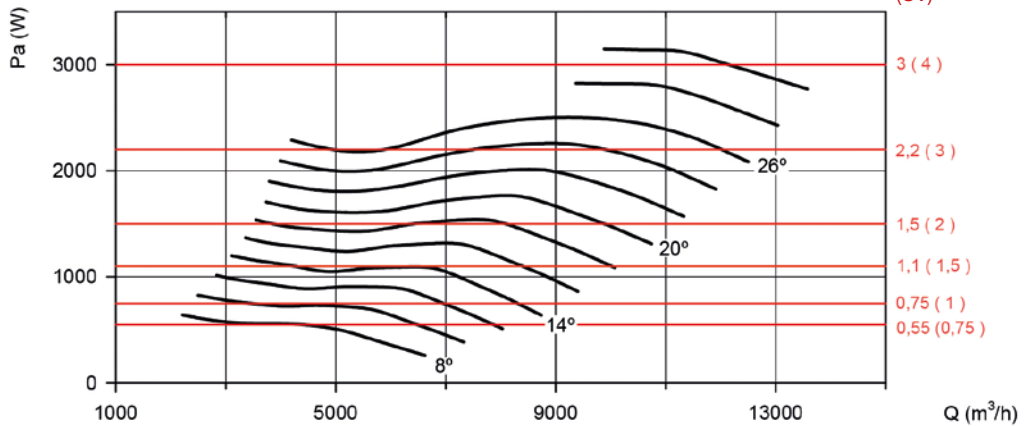

Curve caratteristiche

Q= Portata in m³/h, m³/s e cfm

Pe= Pressione statica in mmH₂O, Pa e inwg

Diametro girante in cm: 45

Numero di poli del motore: 4

Numero di pale: 6

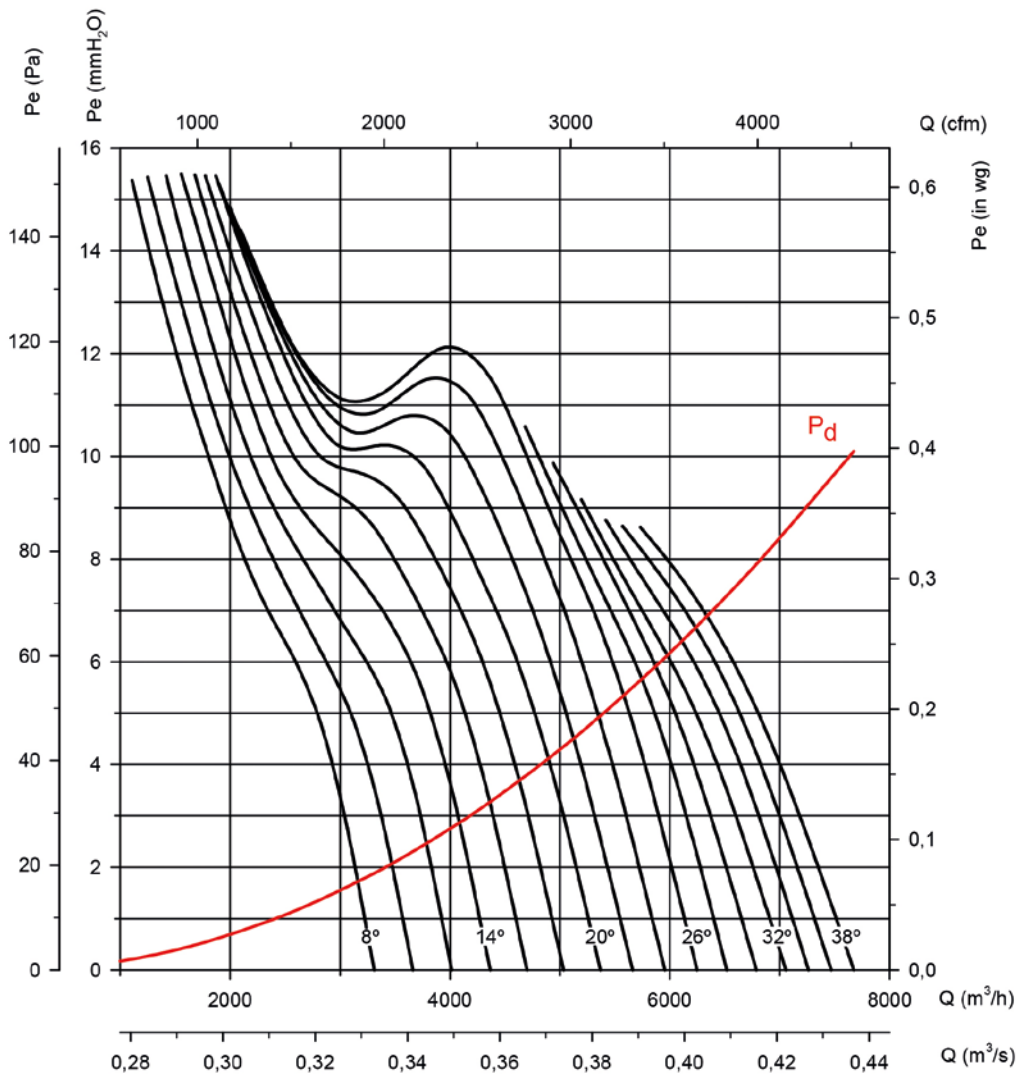

Potenza assorbita

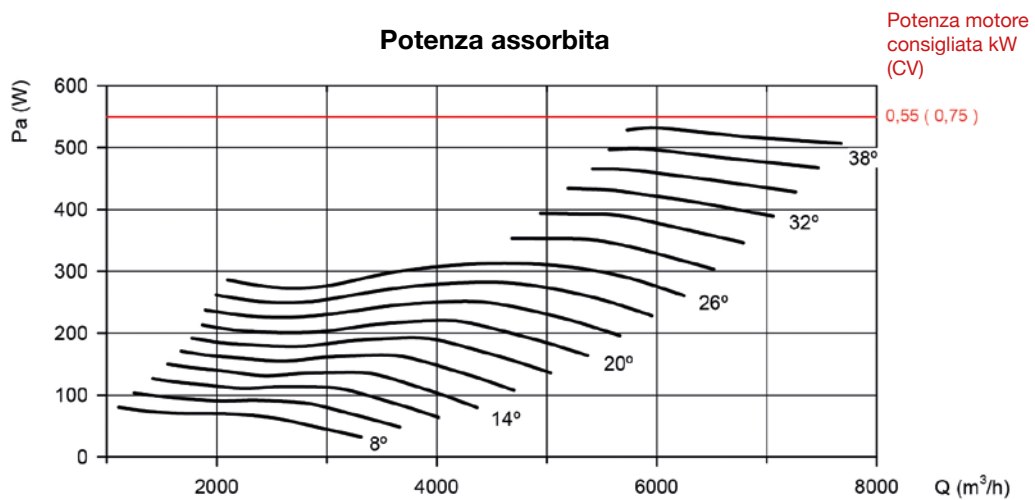

Curve caratteristiche

Q= Portata in m³/h, m³/s e cfm

Pe= Pressione statica in mmH₂O, Pa e inwg

Diametro girante in cm: 45

Numero di poli del motore: 6

Numero di pale: 6

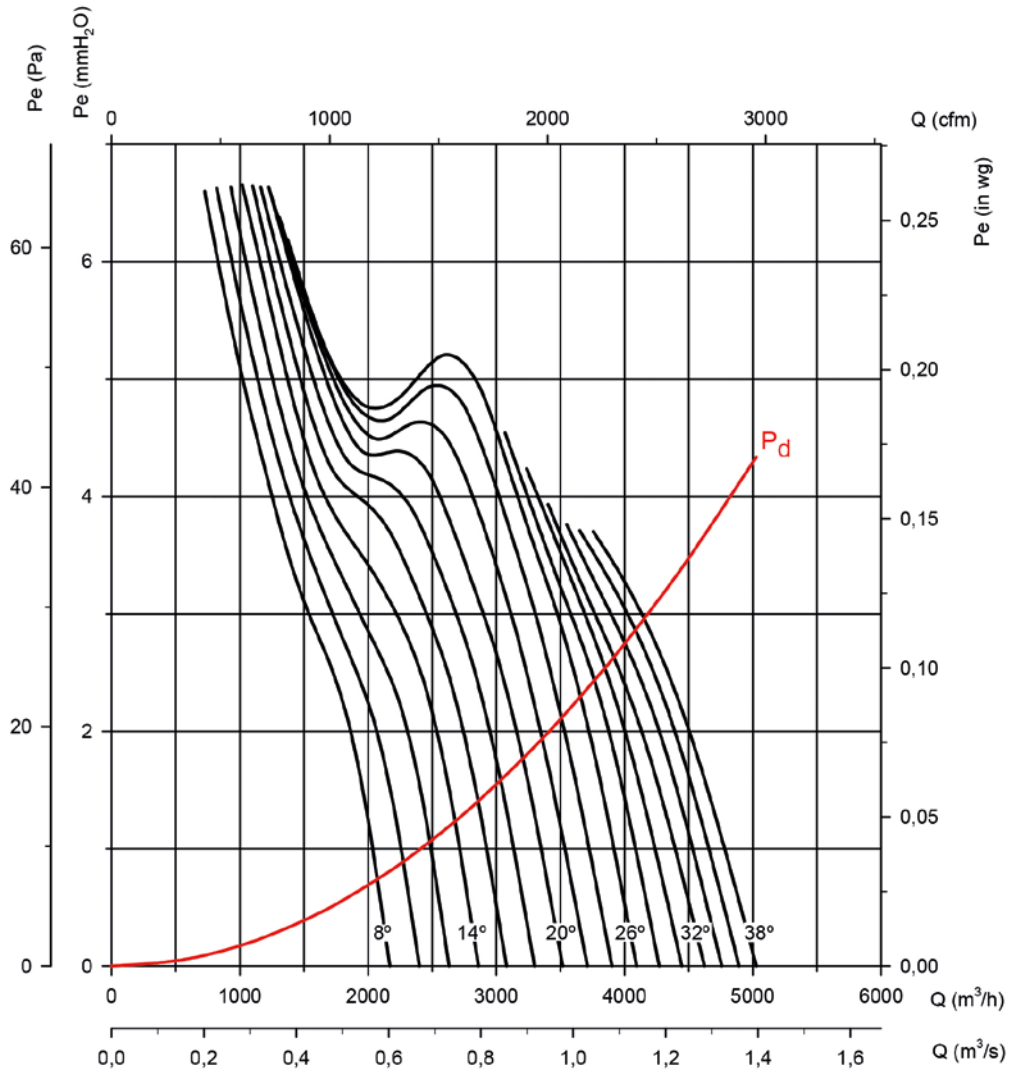

Potenza assorbita

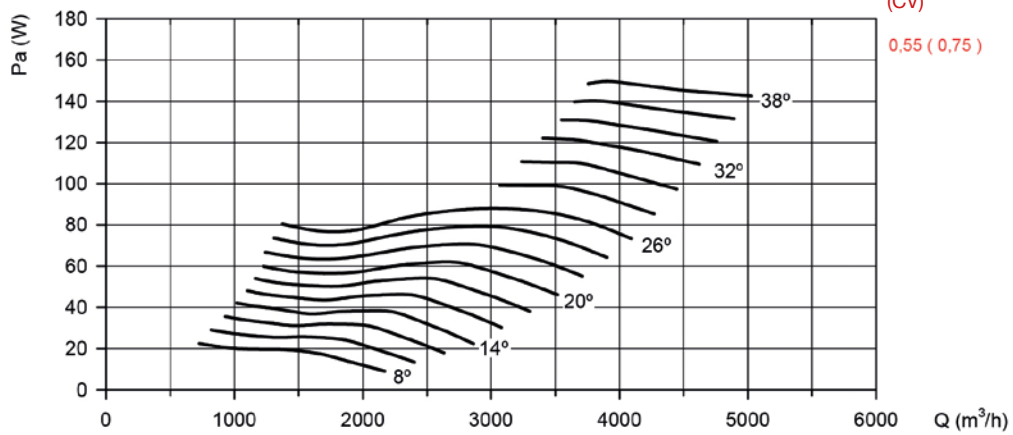

Potenza motore
consigliata kW
(CV)

0,55 (0,75)

Curve caratteristiche

Q= Portata in m³/h, m³/s e cfm

Pe= Pressione statica in mmH₂O, Pa e inwg

Diametro girante in cm: 50

Numero di poli del motore: 4

Numero di pale: 6

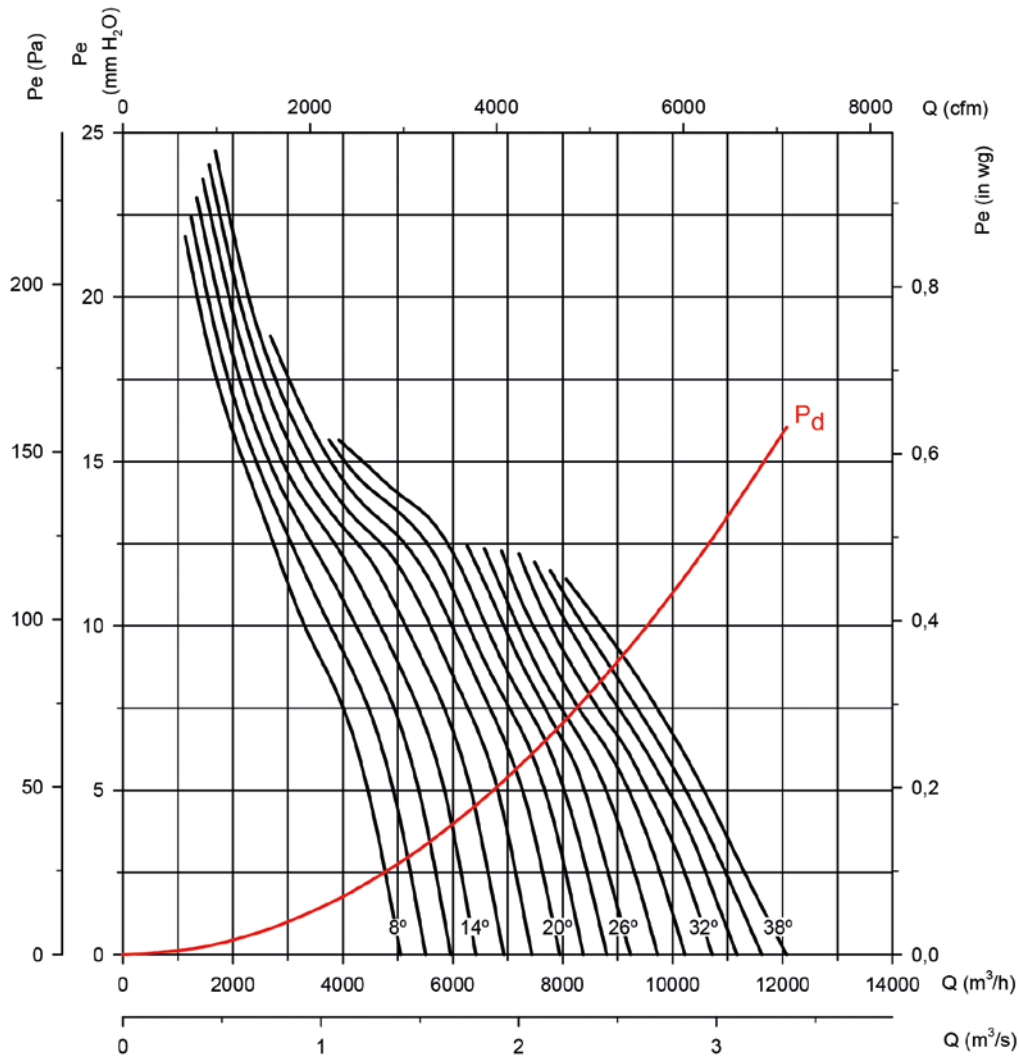

Potenza assorbita

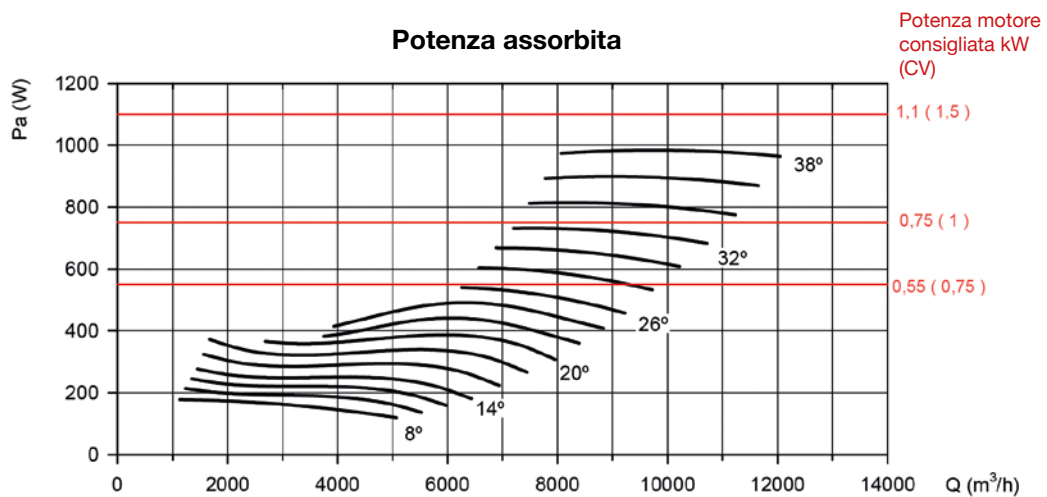

Curve caratteristiche

Q= Portata in m³/h, m³/s e cfm

Pe= Pressione statica in mmH₂O, Pa e inwg

Diametro girante in cm: 50

Numero di poli del motore: 6

Numero di pale: 6

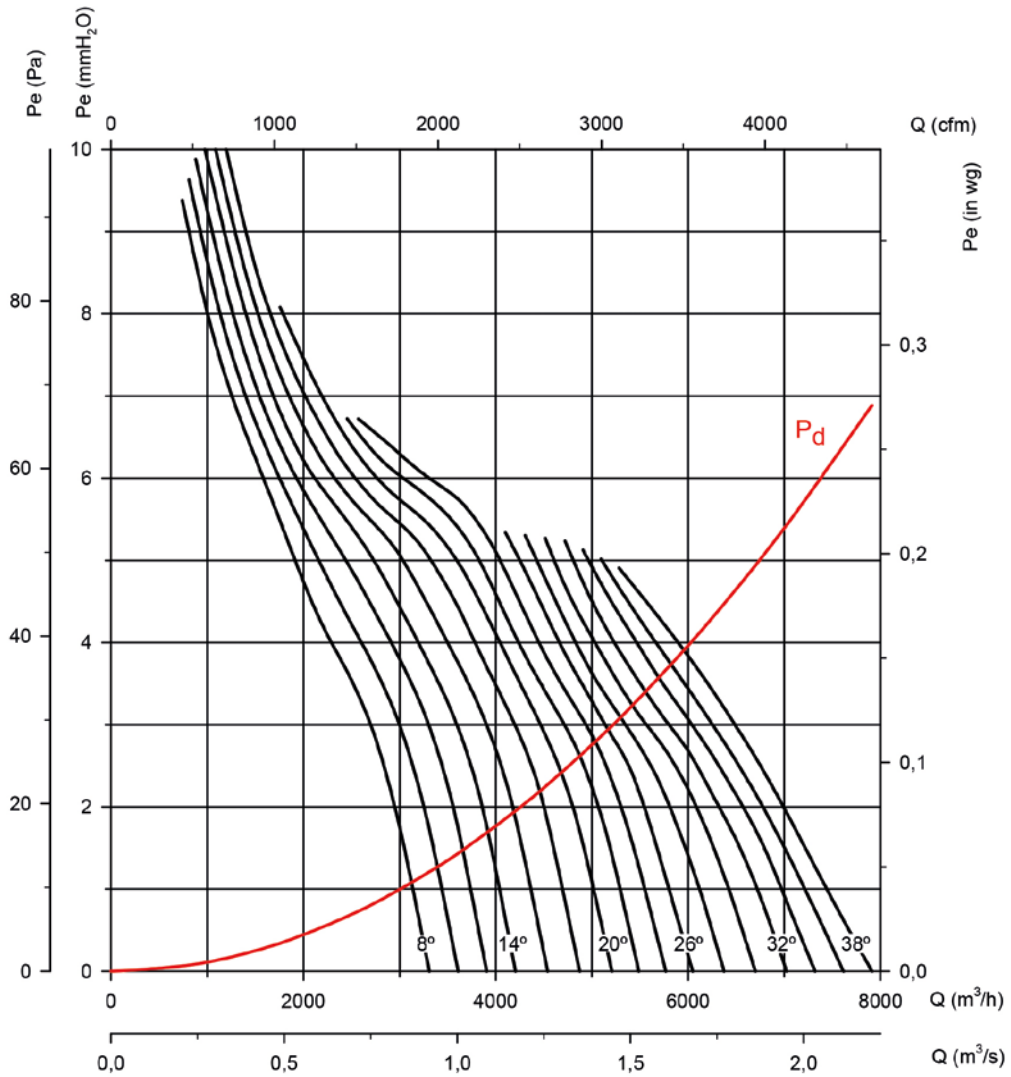

Potenza assorbita

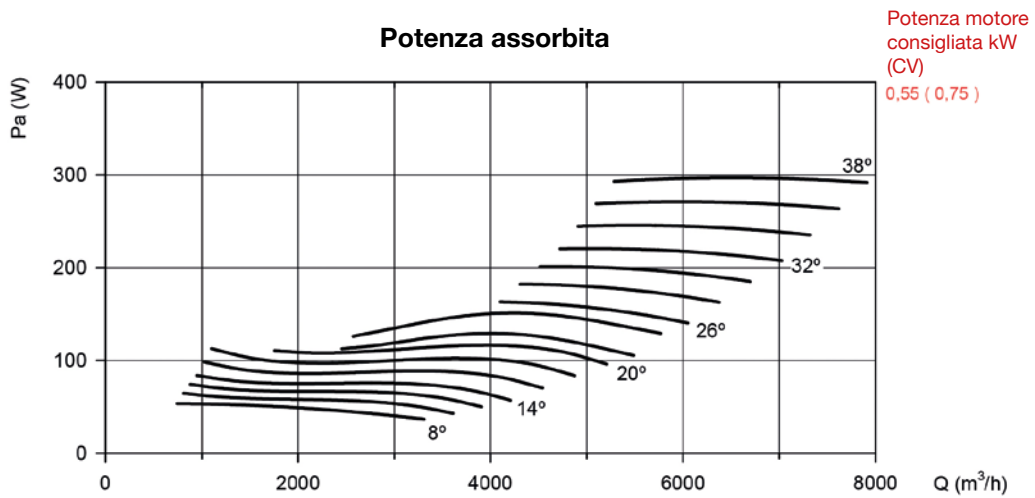

Curve caratteristiche

Q= Portata in m³/h, m³/s e cfm

Pe= Pressione statica in mmH₂O, Pa e inwg

Diametro girante in cm: 56

Numero di poli del motore: 4

Numero di pale: 6

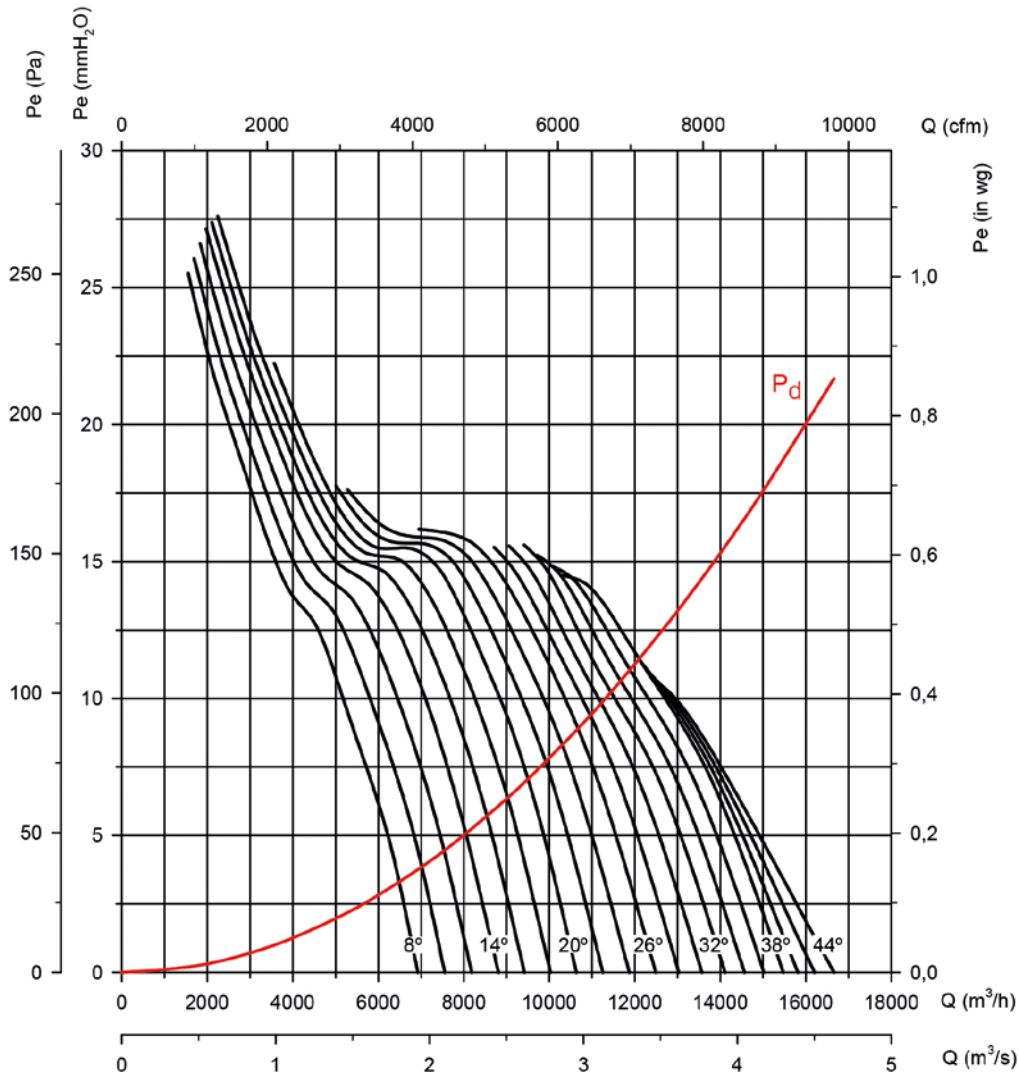

Potenza assorbita

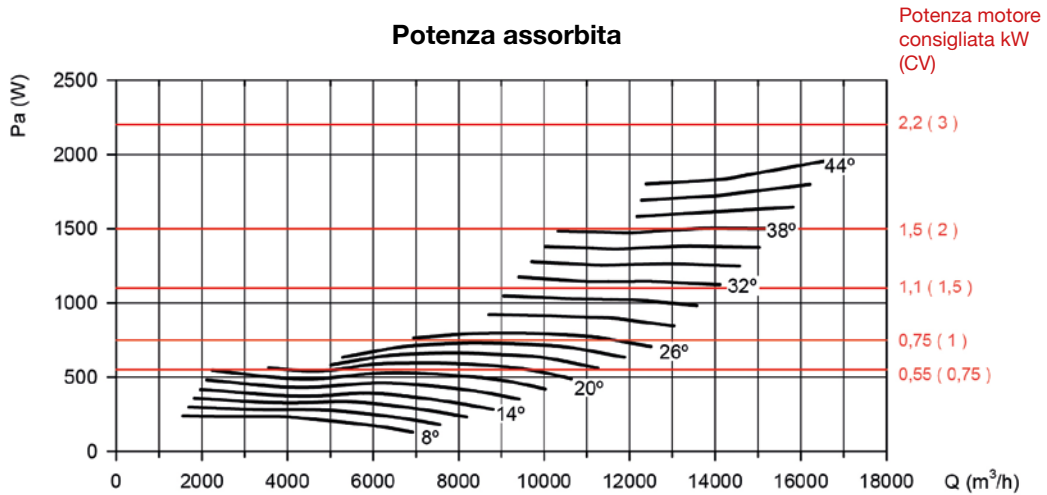

Curve caratteristiche

Q= Portata in m³/h, m³/s e cfm

Pe= Pressione statica in mmH₂O, Pa e inwg

Diametro girante in cm: 56

Numero di poli del motore: 6

Numero di pale: 6

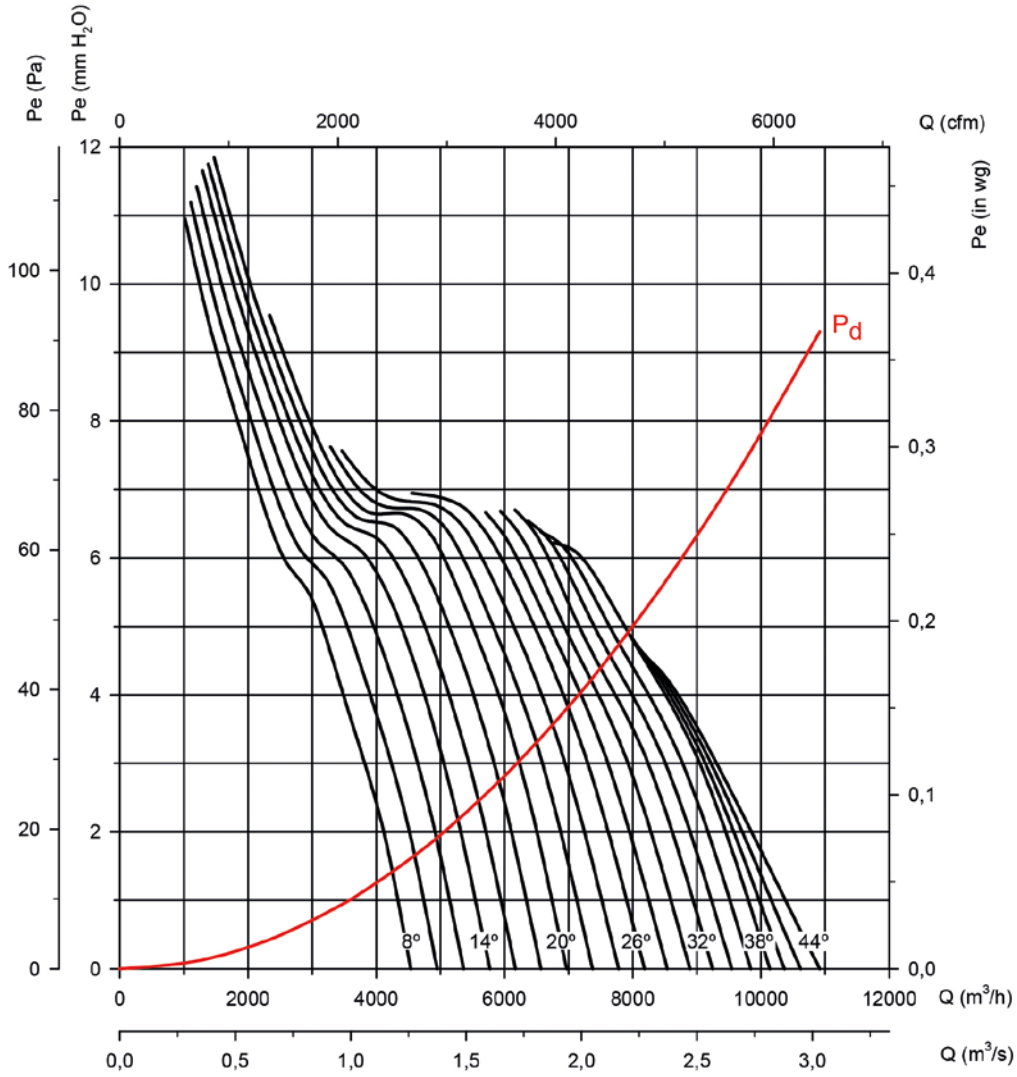

Potenza assorbita

Potenza motore consigliata kW (CV)

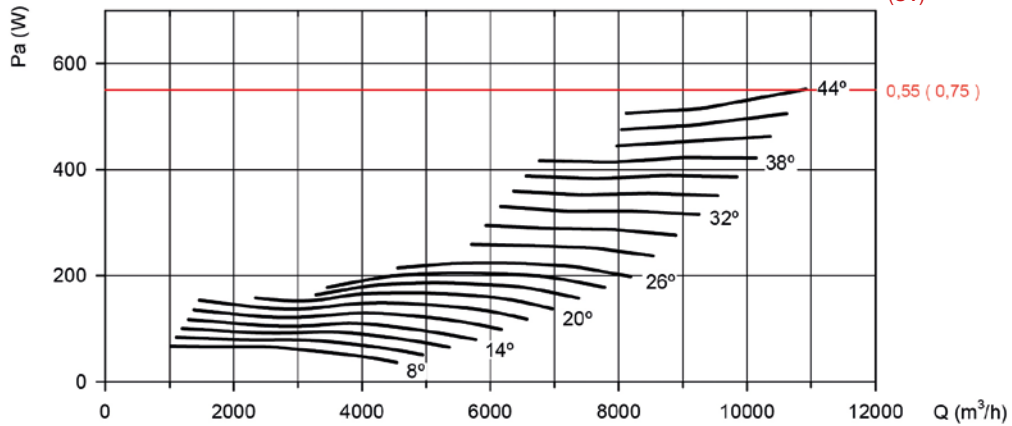

Curve caratteristiche

Q= Portata in m³/h, m³/s e cfm

Pe= Pressione statica in mmH₂O, Pa e inwg

Diametro girante in cm: 63

Numero di poli del motore: 4

Numero di pale: 6

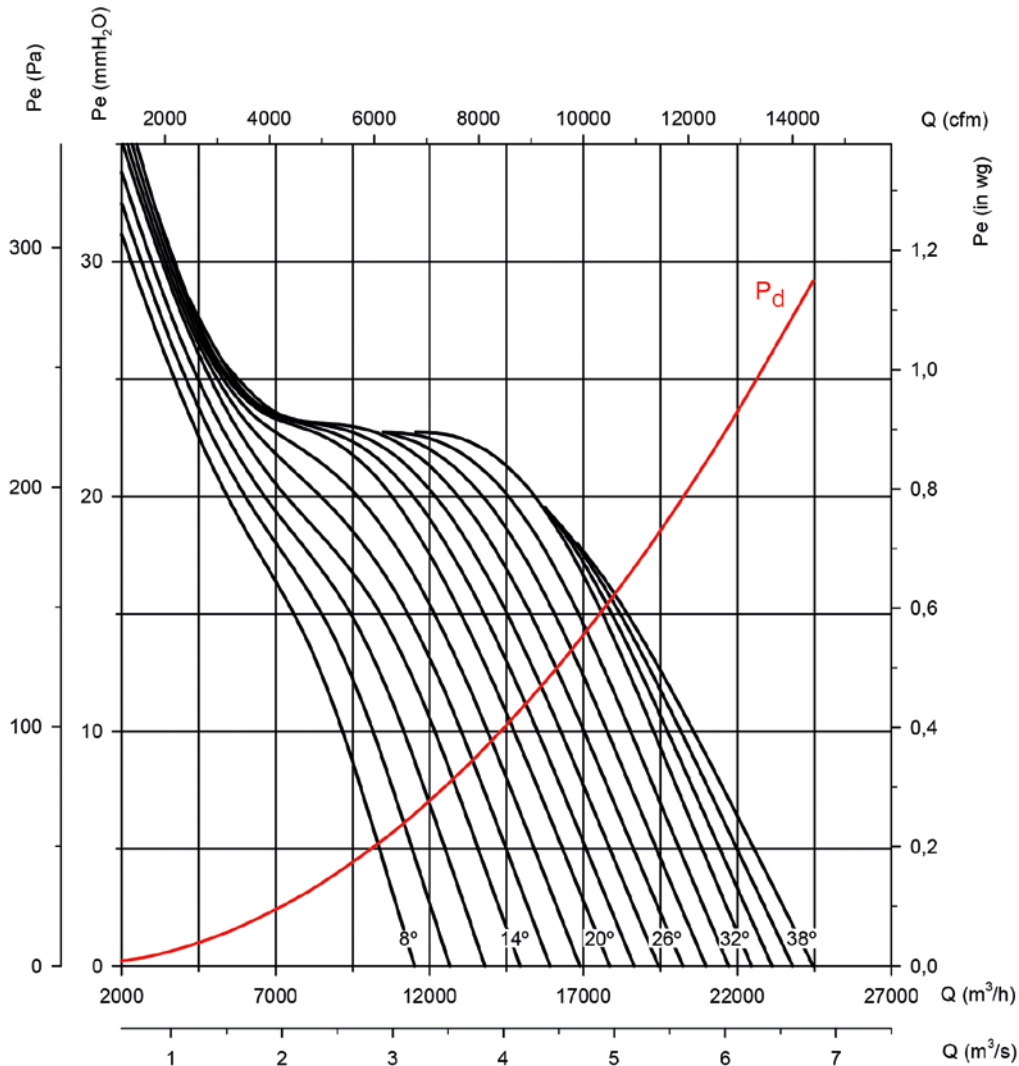

Potenza assorbita

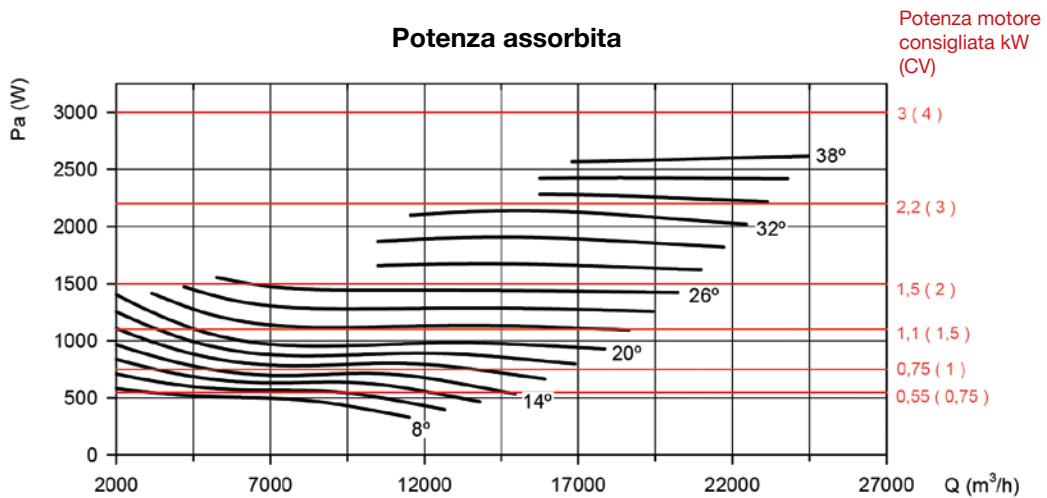

Curve caratteristiche

Q= Portata in m³/h, m³/s e cfm

Pe= Pressione statica in mmH₂O, Pa e inwg

Diametro girante in cm: 63

Numero di poli del motore: 6

Numero di pale: 6

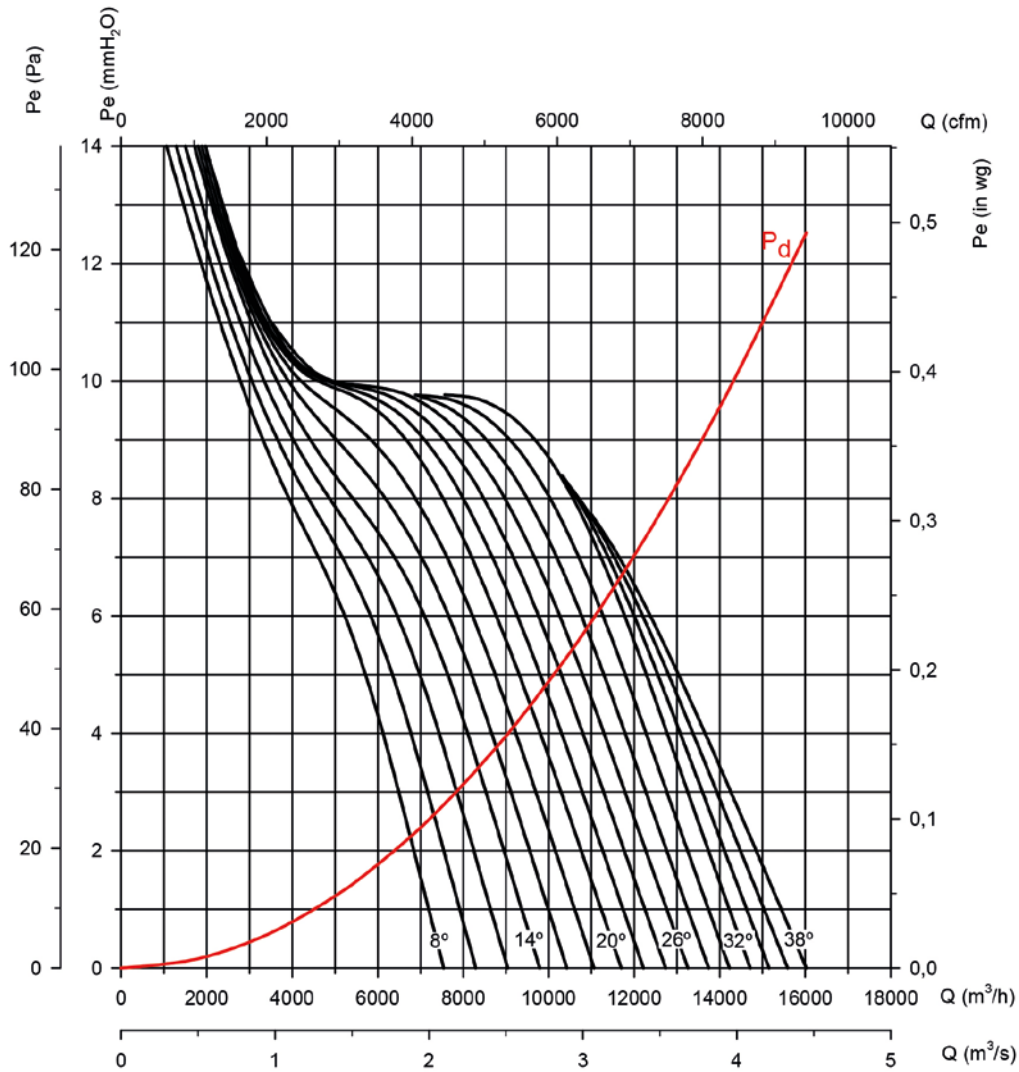

Potenza assorbita

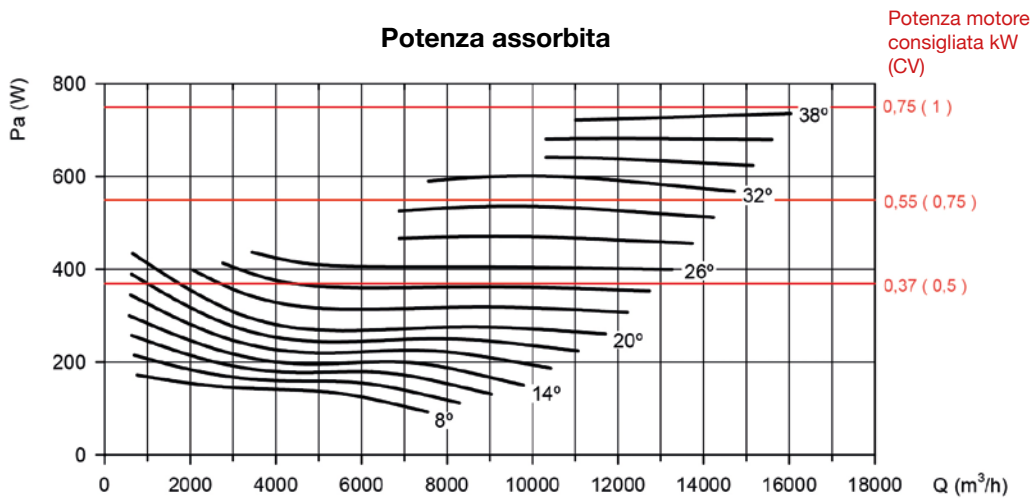

Curve caratteristiche

Q= Portata in m³/h, m³/s e cfm

Pe= Pressione statica in mmH₂O, Pa e inwg

Diametro girante in cm: 71

Numero di poli del motore: 4

Numero di pale: 6

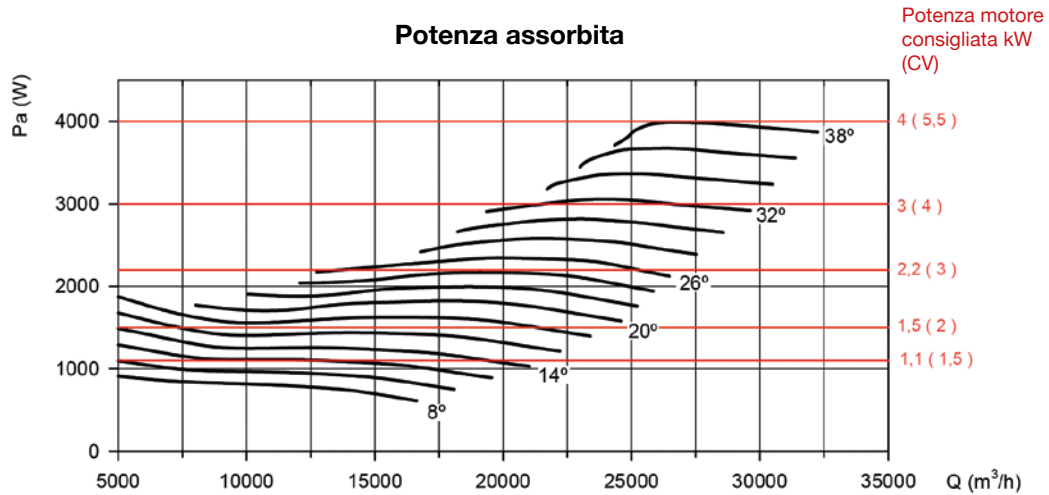
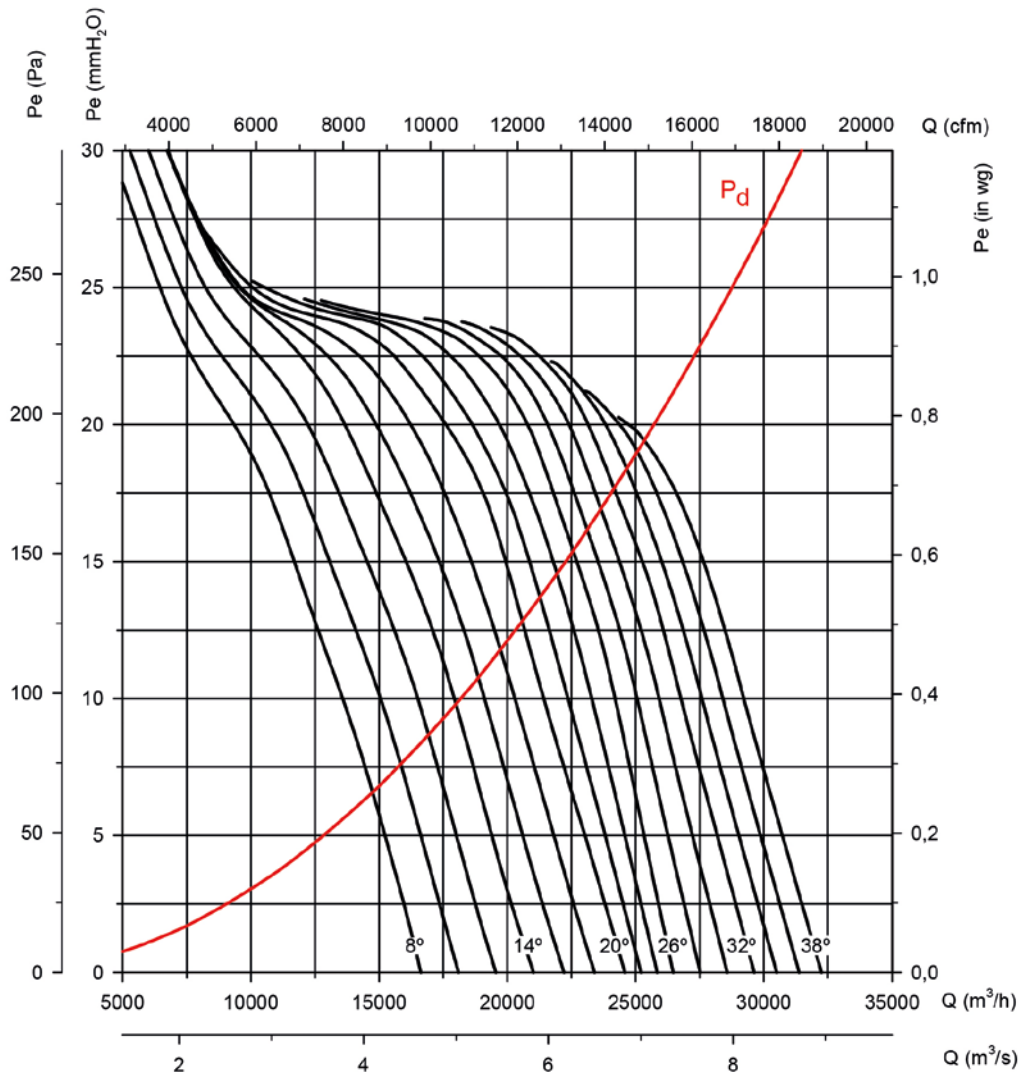

Curve caratteristiche

Q= Portata in m³/h, m³/s e cfm

Pe= Pressione statica in mmH₂O, Pa e inwg

Diametro girante in cm: 71

Numero di poli del motore: 6

Numero di pale: 6

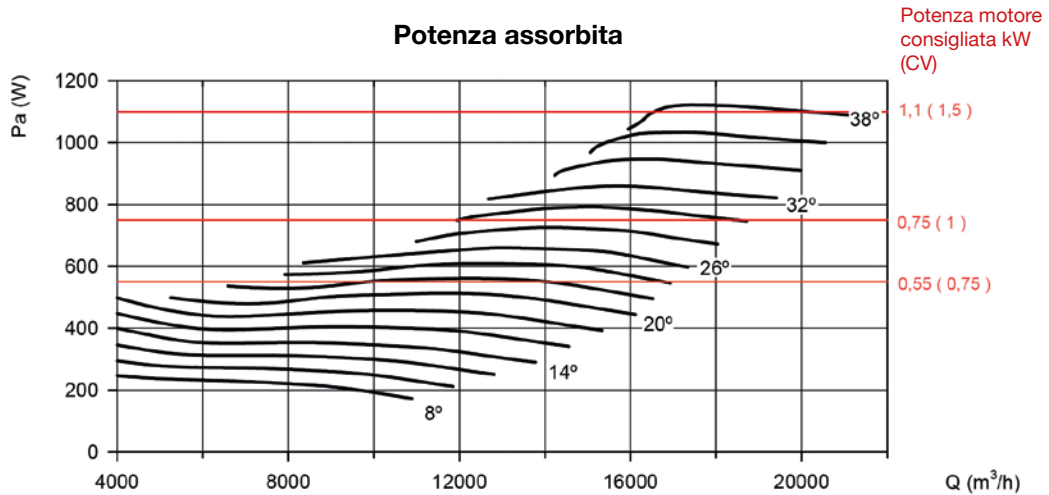
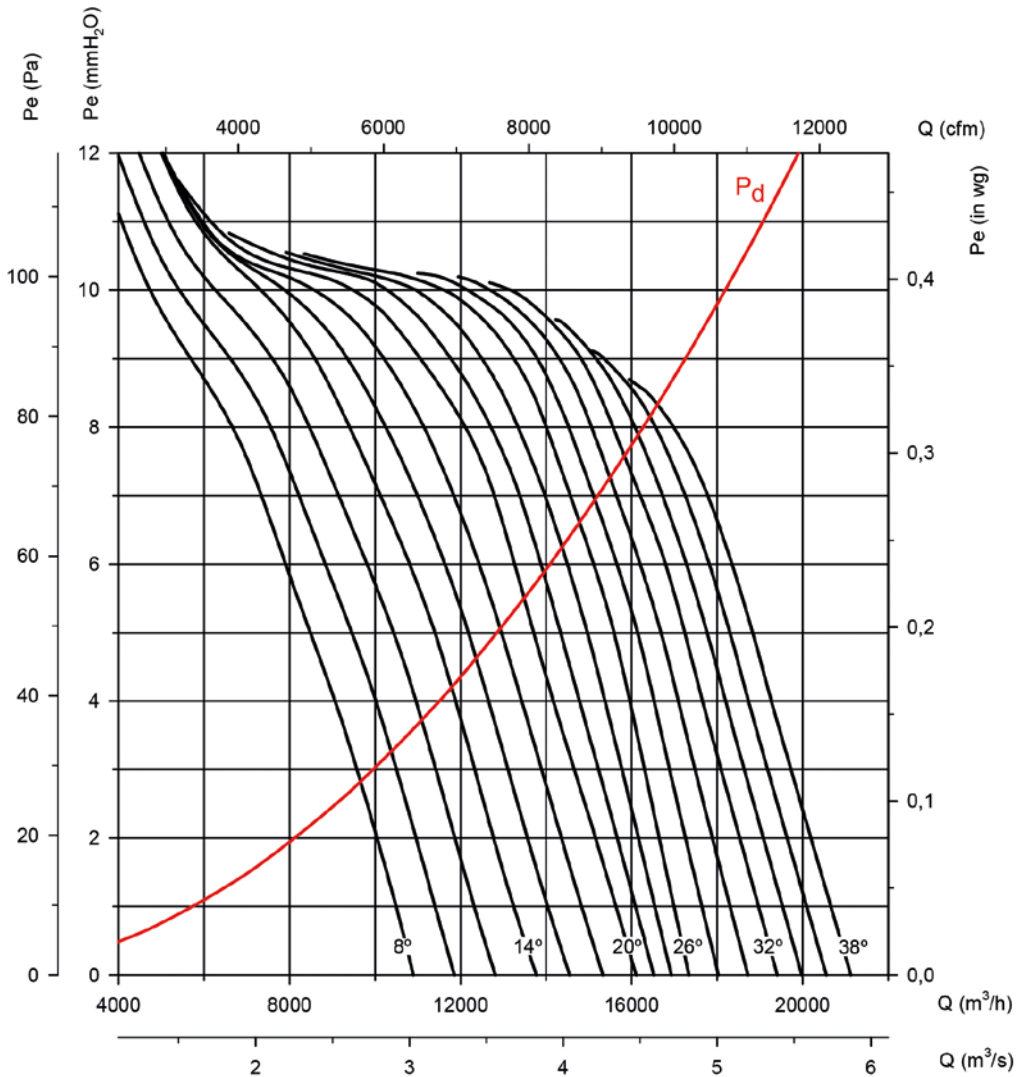

Curve caratteristiche

Q= Portata in m³/h, m³/s e cfm

Pe= Pressione statica in mmH₂O, Pa e inwg

Diametro girante in cm: 80

Numero di poli del motore: 4

Numero di pale: 6

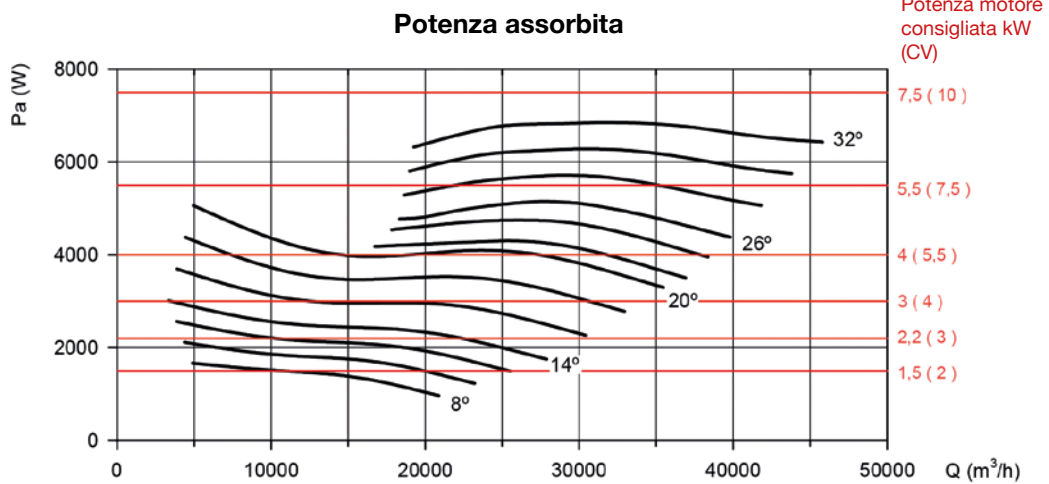
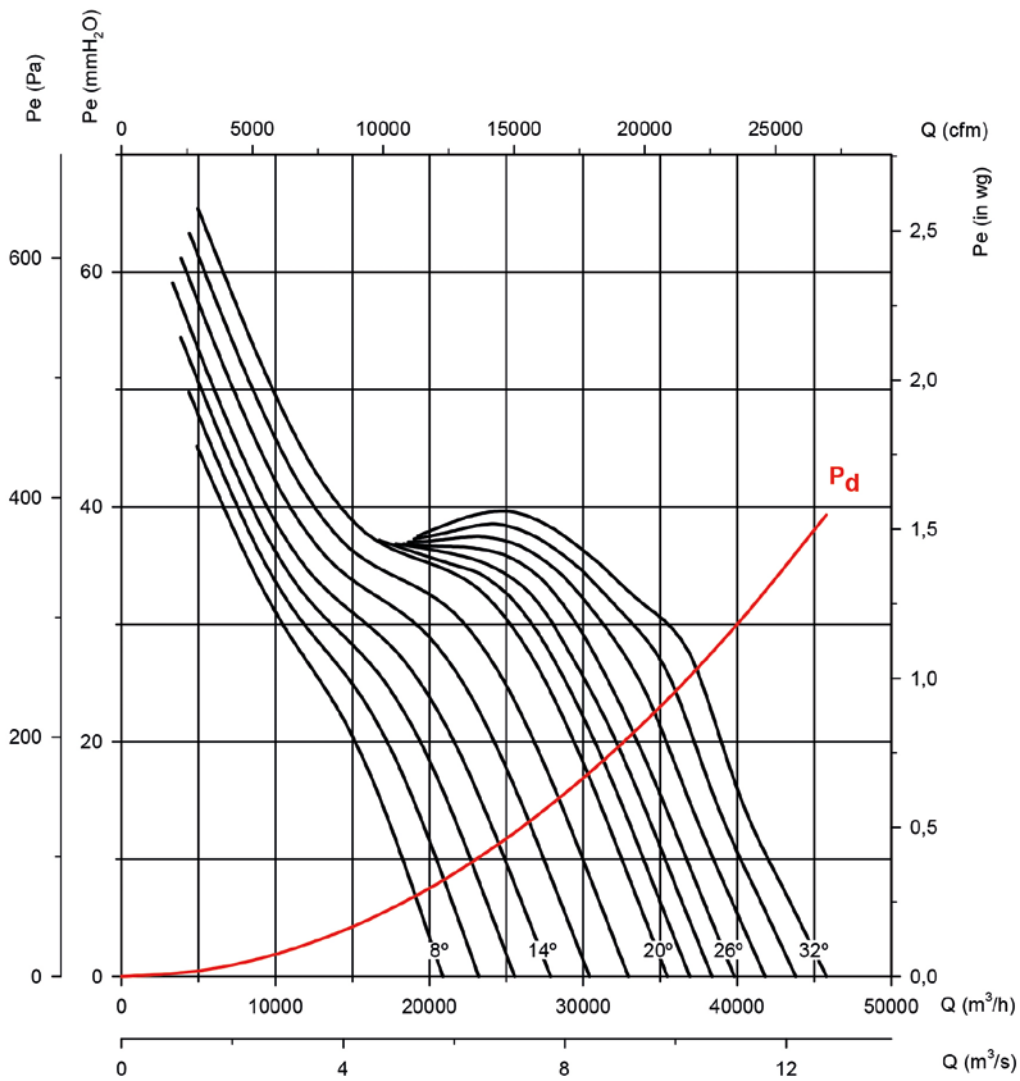

Curve caratteristiche

Q= Portata in m³/h, m³/s e cfm

Pe= Pressione statica in mmH₂O, Pa e inwg

Diametro girante in cm: 80

Numero di poli del motore: 6

Numero di pale: 6

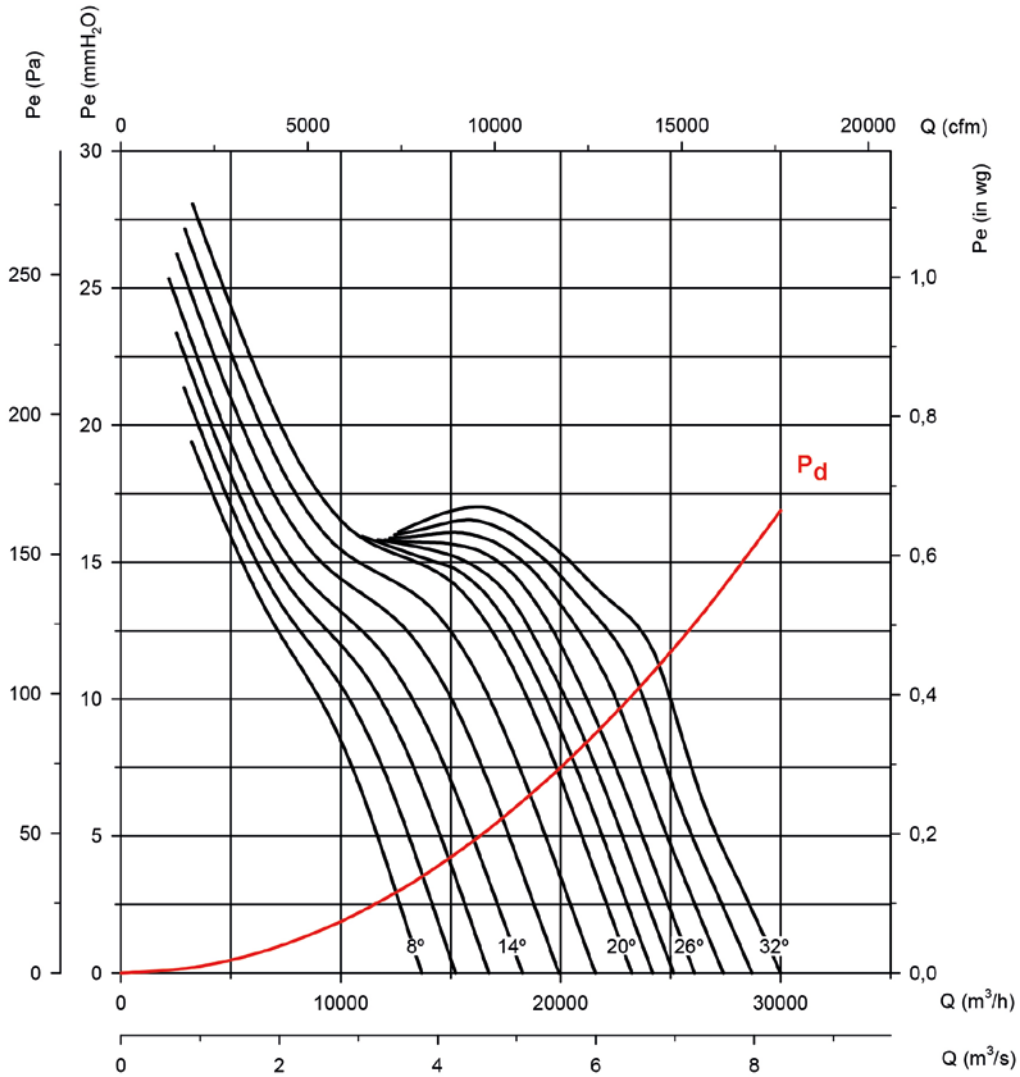

Potenza assorbita

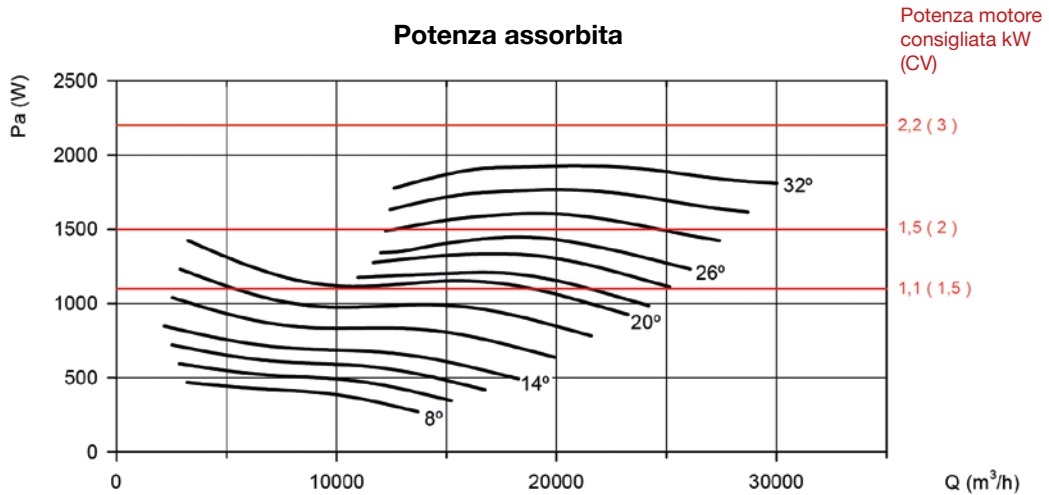

Curve caratteristiche

Q= Portata in m³/h, m³/s e cfm

Pe= Pressione statica in mmH₂O, Pa e inwg

Diametro girante in cm: 80

Numero di poli del motore: 8

Numero di pale: 6

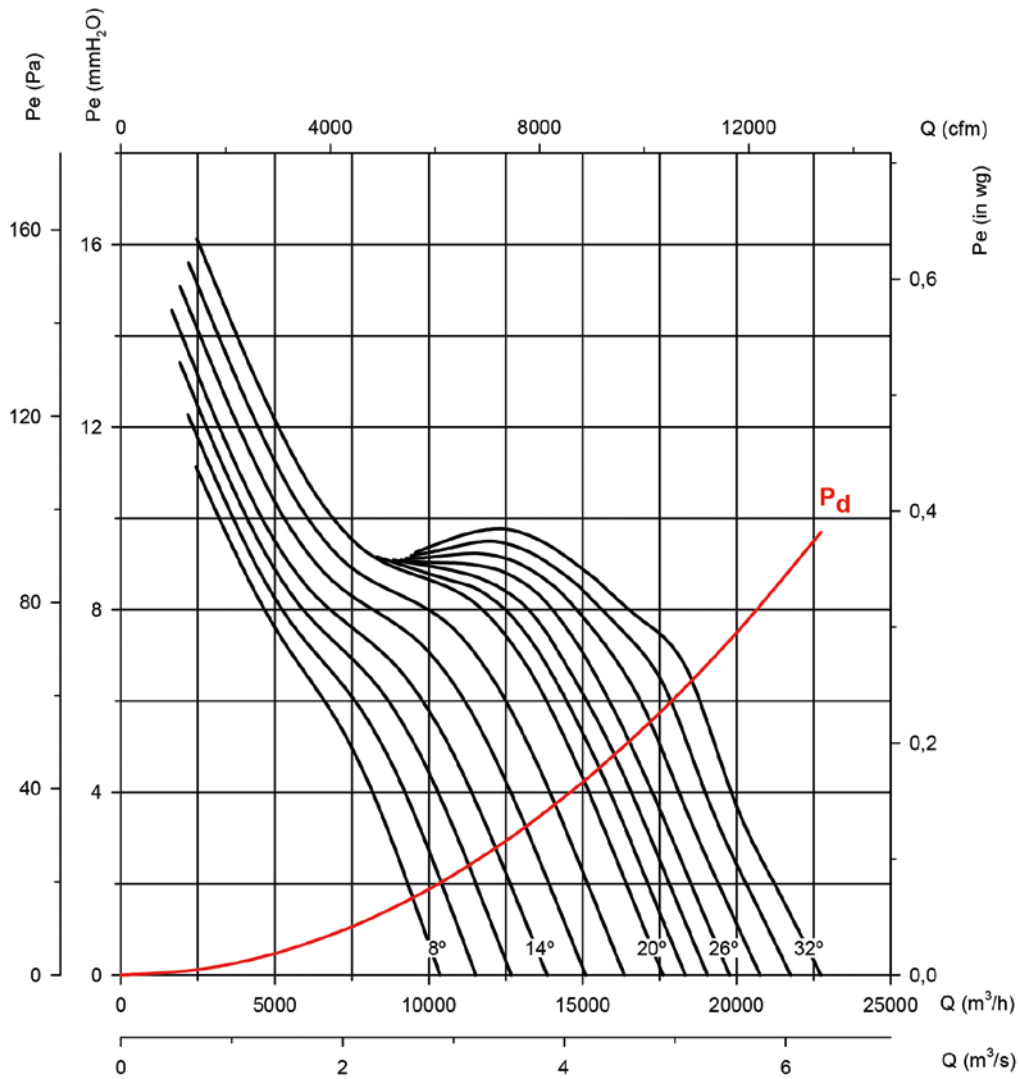

Potenza assorbita

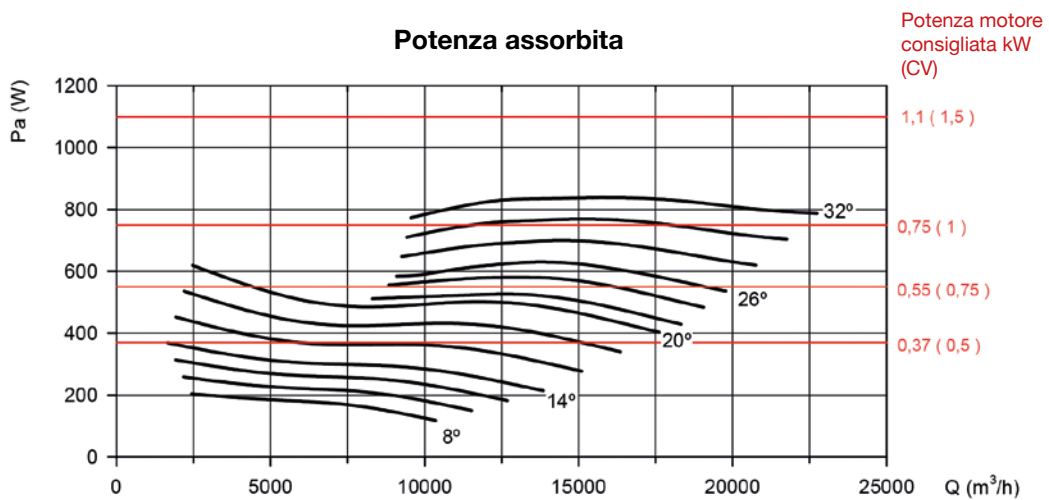

Curve caratteristiche

Q= Portata in m³/h, m³/s e cfm

Pe= Pressione statica in mmH₂O, Pa e inwg

Diametro girante in cm: 90

Numero di poli del motore: 4

Numero di pale: 6

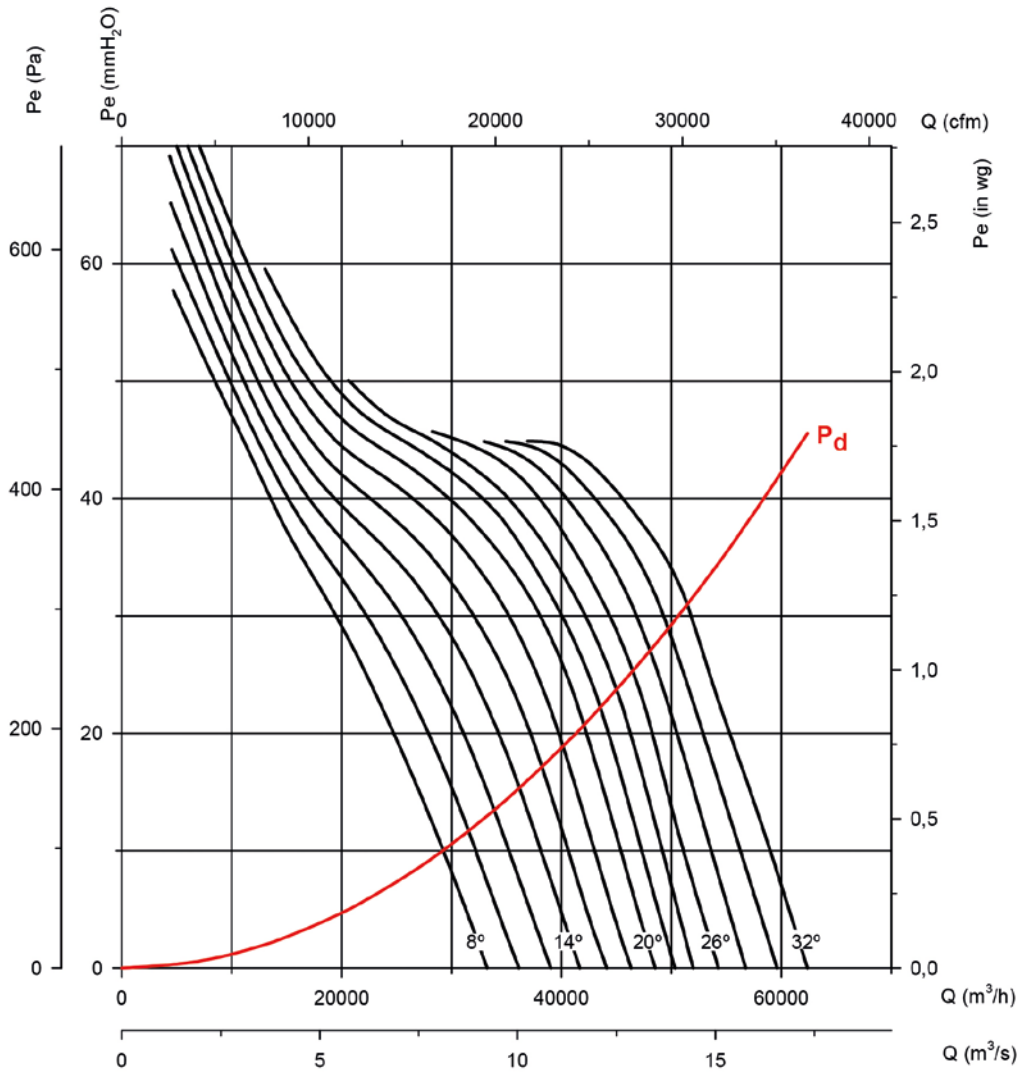

Potenza assorbita

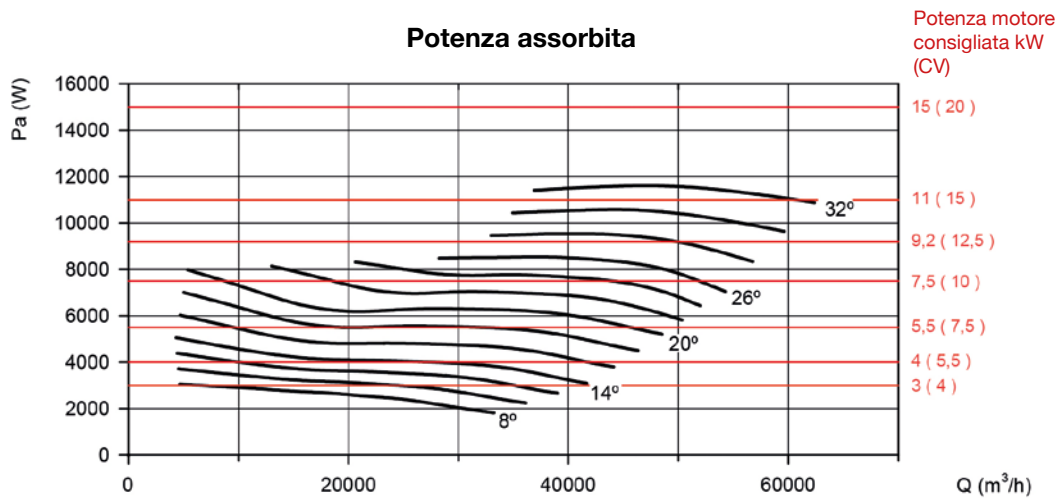

Curve caratteristiche

Q= Portata in m³/h, m³/s e cfm

Pe= Pressione statica in mmH₂O, Pa e inwg

Diametro girante in cm: 90

Numero di poli del motore: 6

Numero di pale: 6

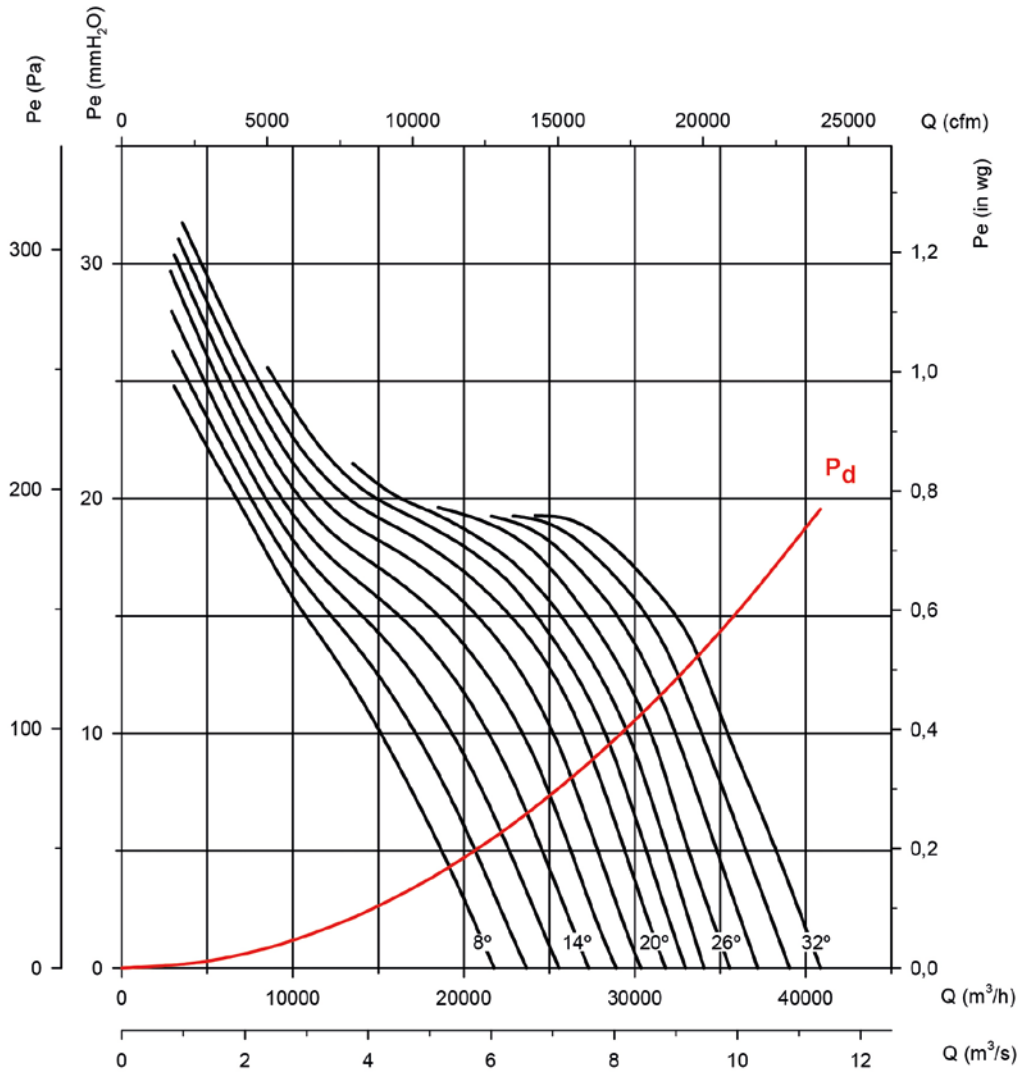

Potenza assorbita

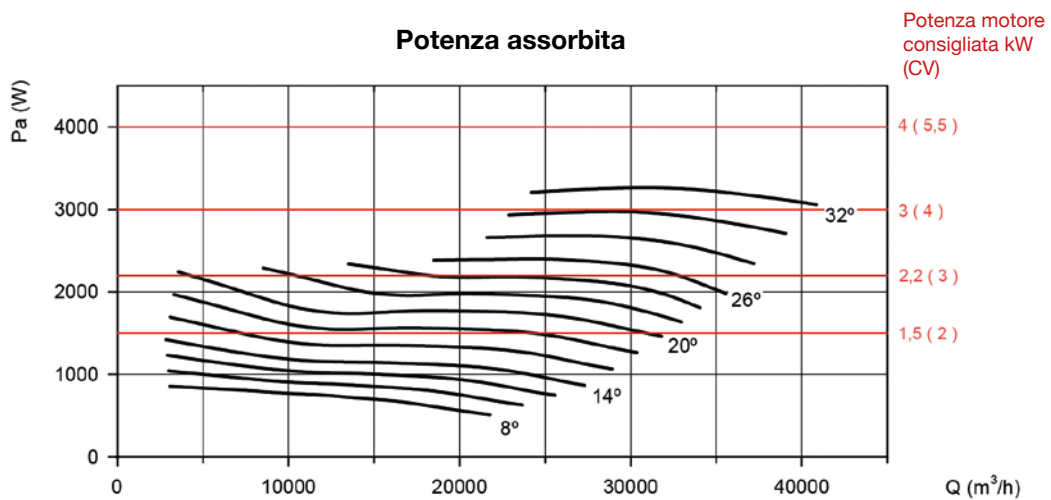

Curve caratteristiche

Q= Portata in m³/h, m³/s e cfm

Pe= Pressione statica in mmH₂O, Pa e inwg

Diametro girante in cm: 90

Numero di poli del motore: 8

Numero di pale: 6

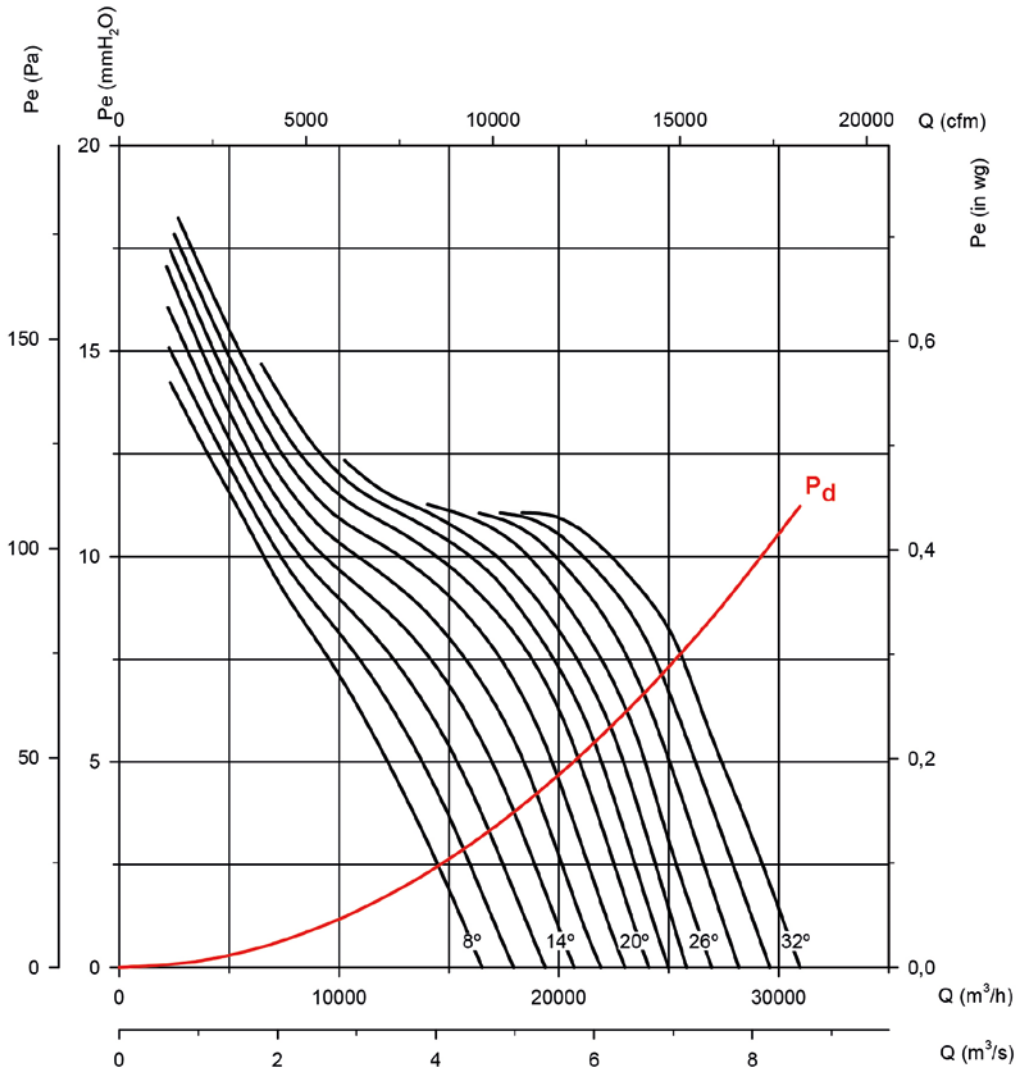

Potenza assorbita

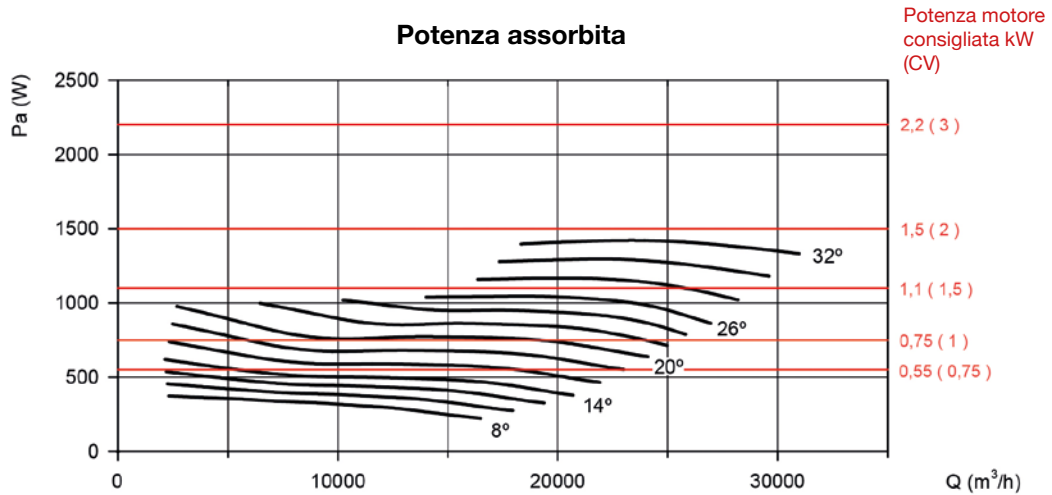

Curve caratteristiche

Q= Portata in m³/h, m³/s e cfm

Pe= Pressione statica in mmH₂O, Pa e inwg

Diametro girante in cm: 100

Numero di poli del motore: 4

Numero di pale: 6

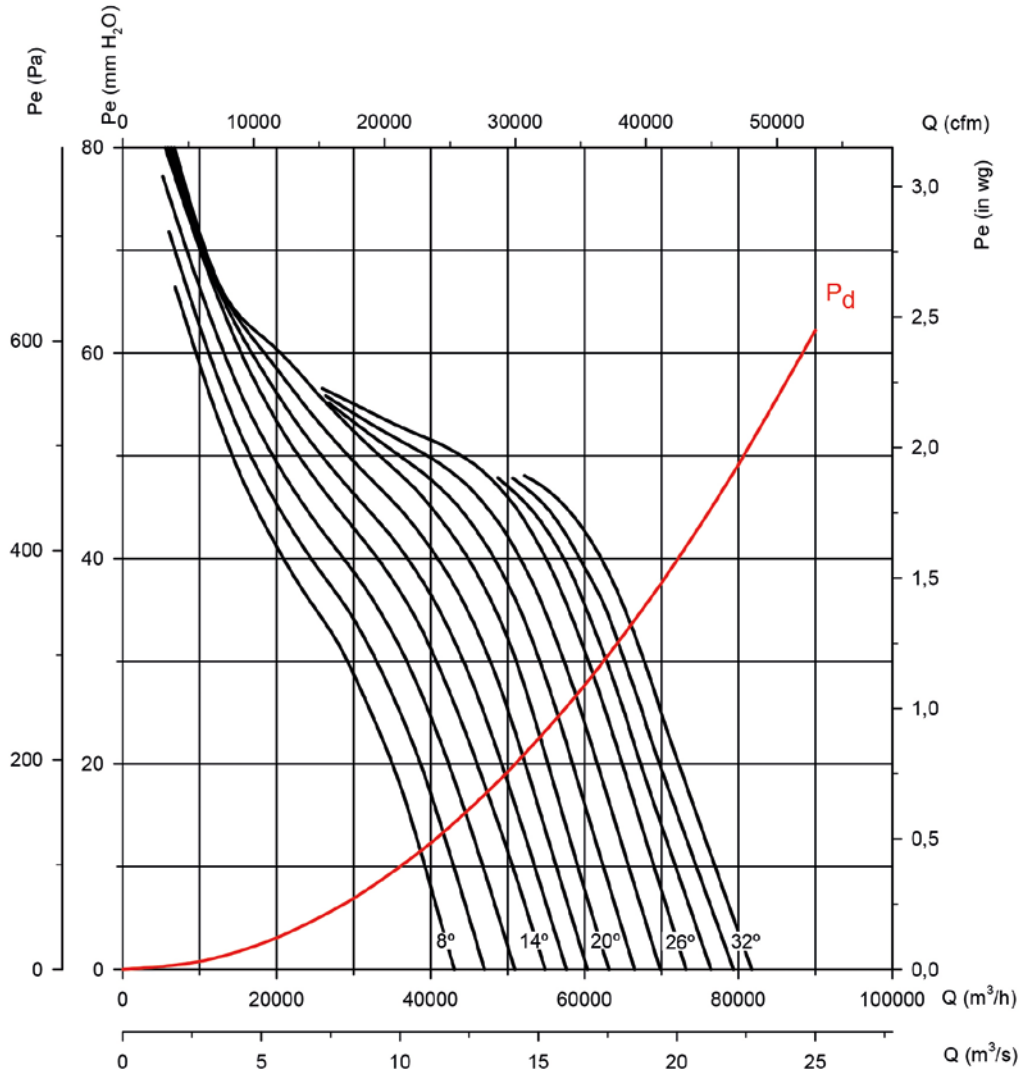

Potenza assorbita

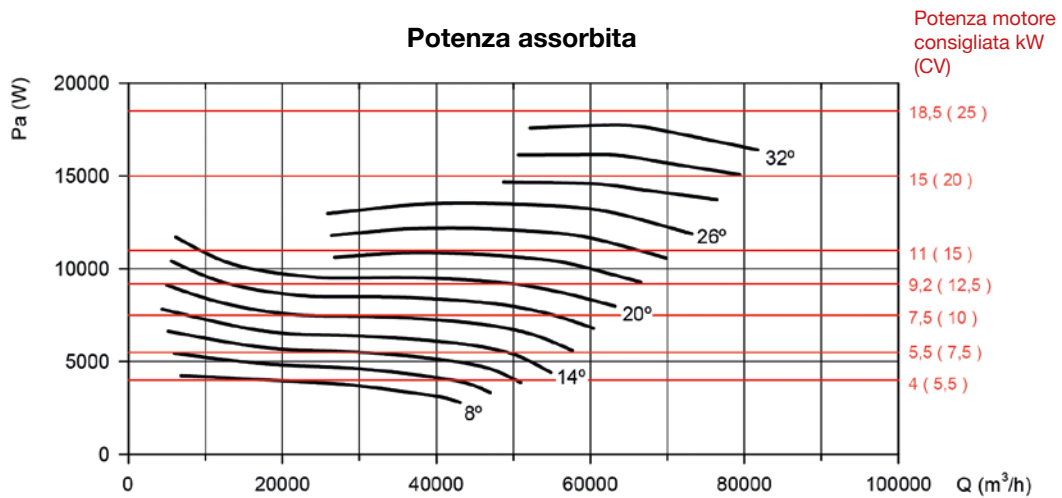

Curve caratteristiche

Q= Portata in m³/h, m³/s e cfm

Pe= Pressione statica in mmH₂O, Pa e inwg

Diametro girante in cm: 100

Numero di poli del motore: 4

Numero di pale: 9

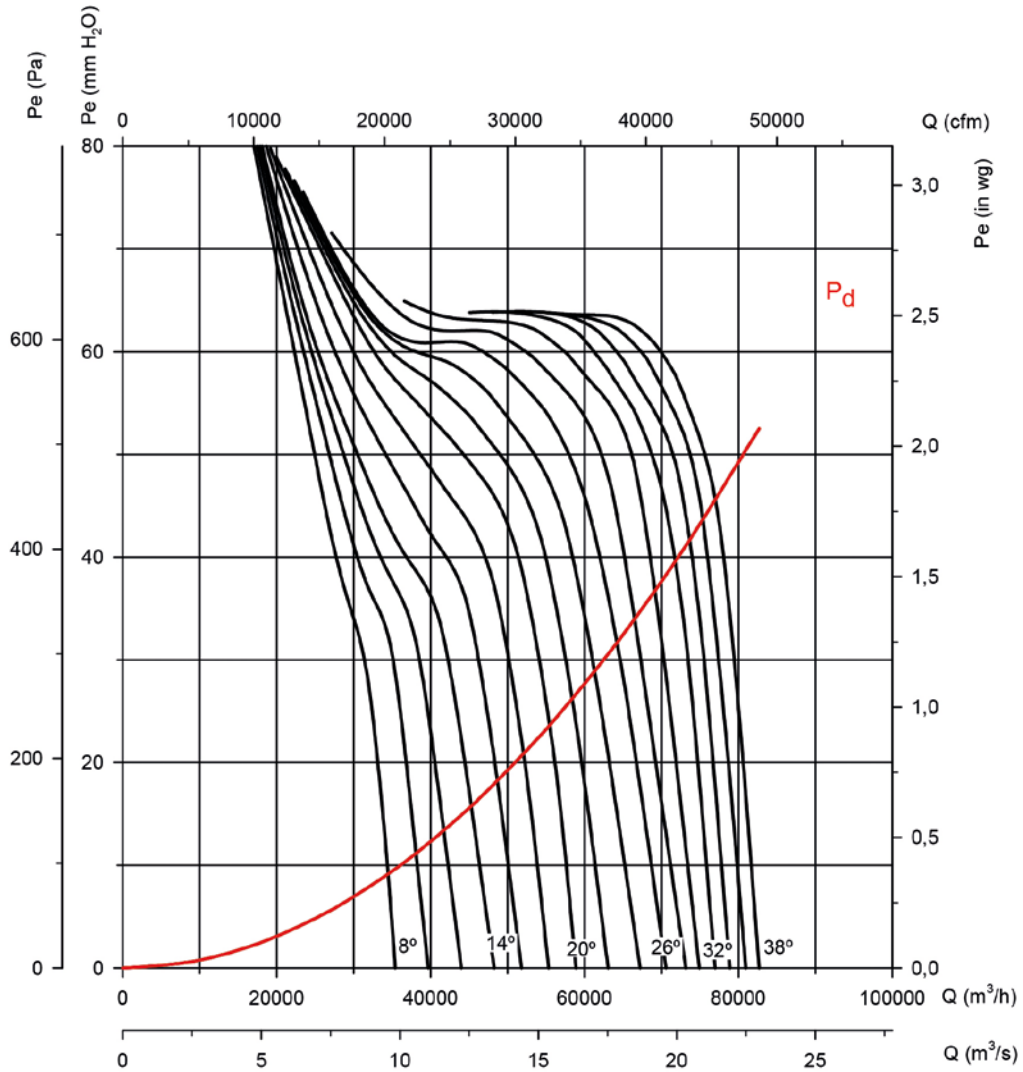

Potenza assorbita

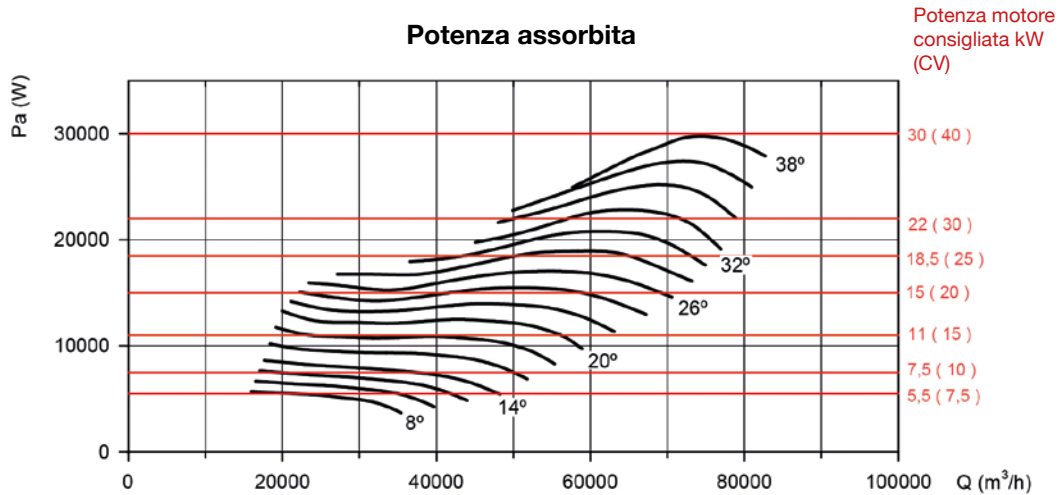

Curve caratteristiche

Q= Portata in m³/h, m³/s e cfm

Pe= Pressione statica in mmH₂O, Pa e inwg

Diametro girante in cm: 100

Numero di poli del motore: 6

Numero di pale: 6

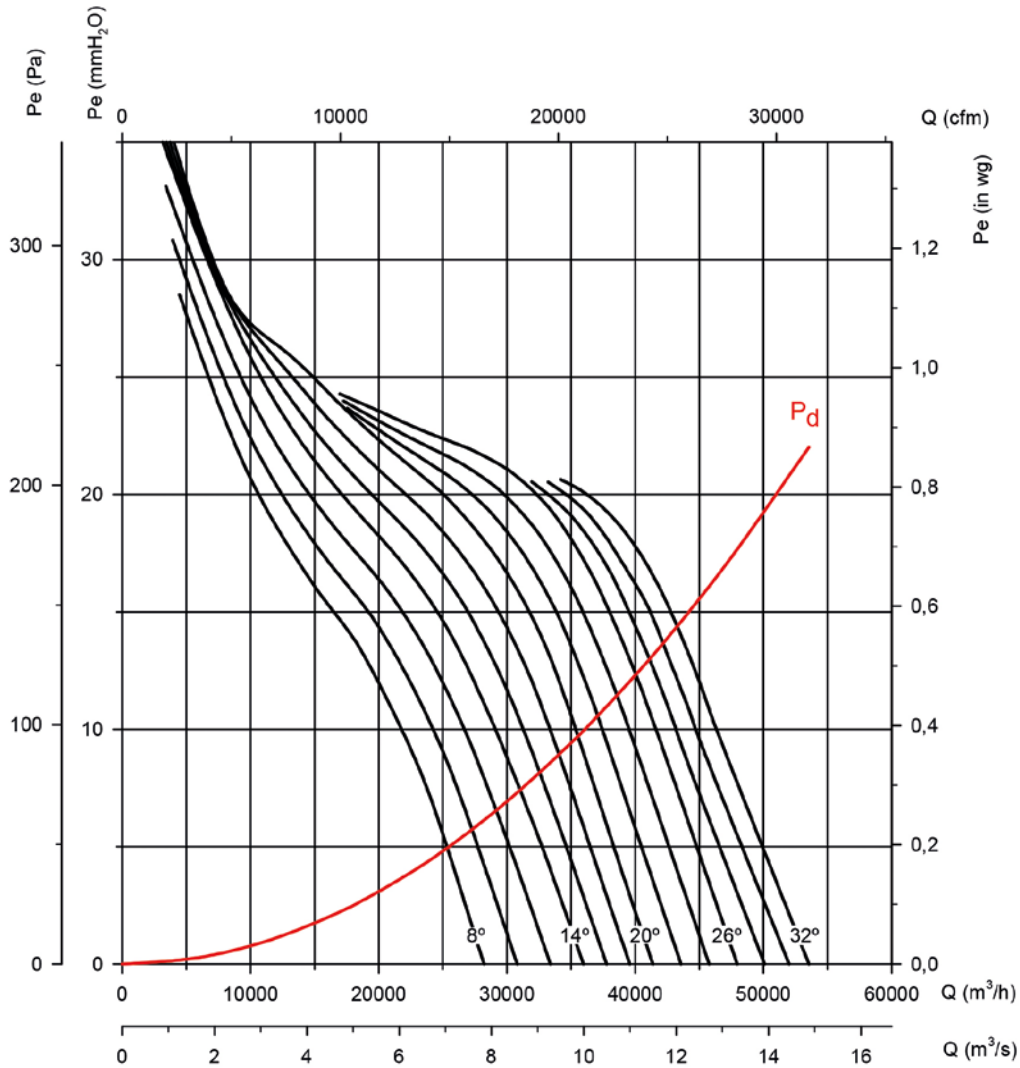

Potenza assorbita

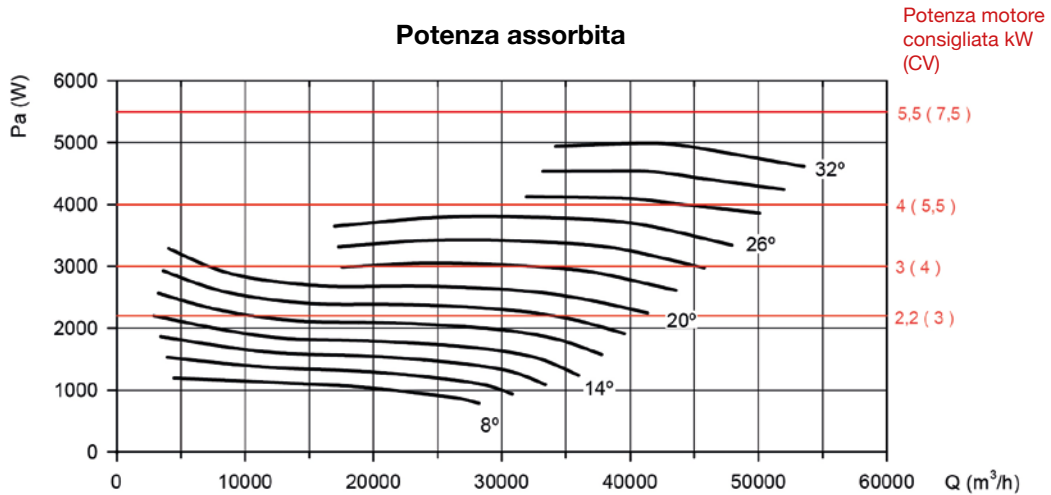

Curve caratteristiche

Q= Portata in m³/h, m³/s e cfm

Pe= Pressione statica in mmH₂O, Pa e inwg

Diametro girante in cm: 100

Numero di poli del motore: 6

Numero di pale: 9

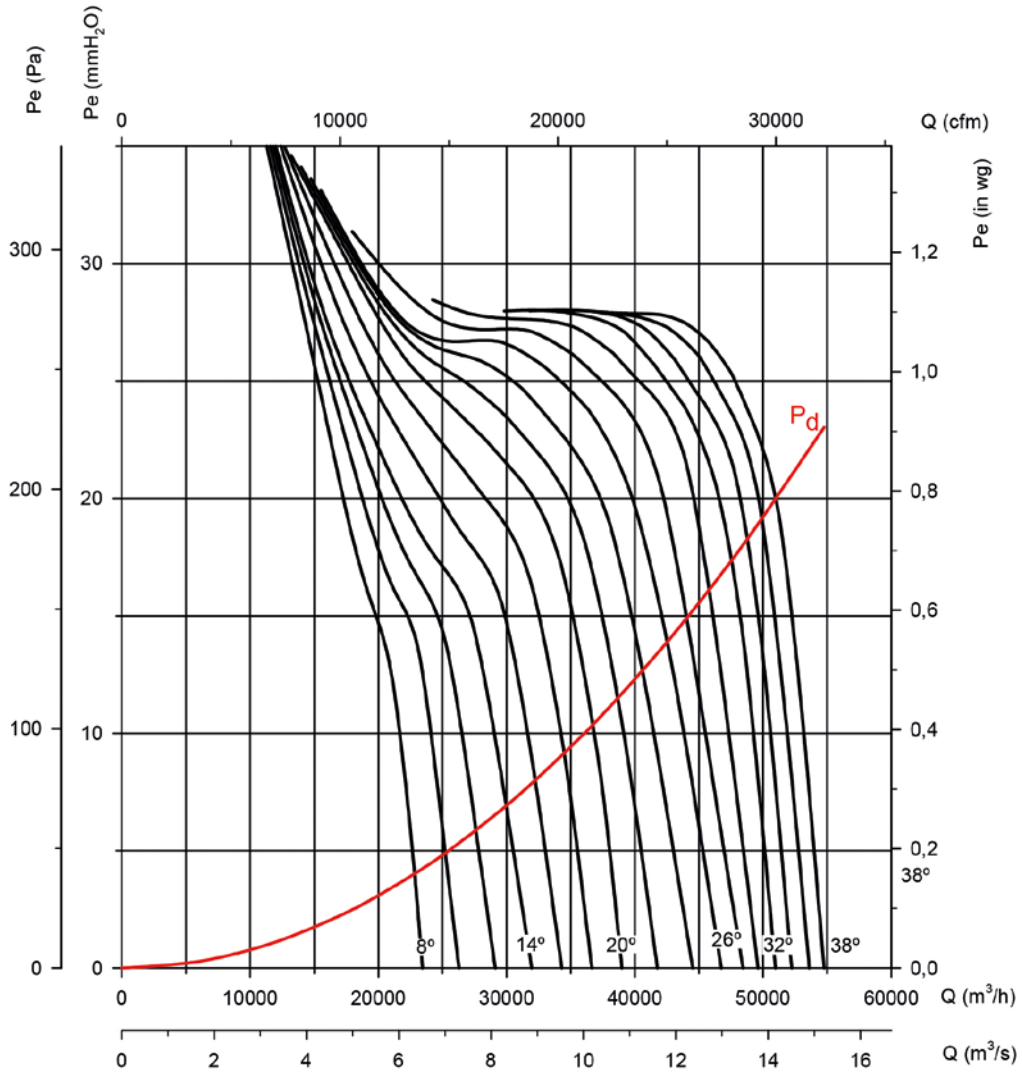

Potenza assorbita

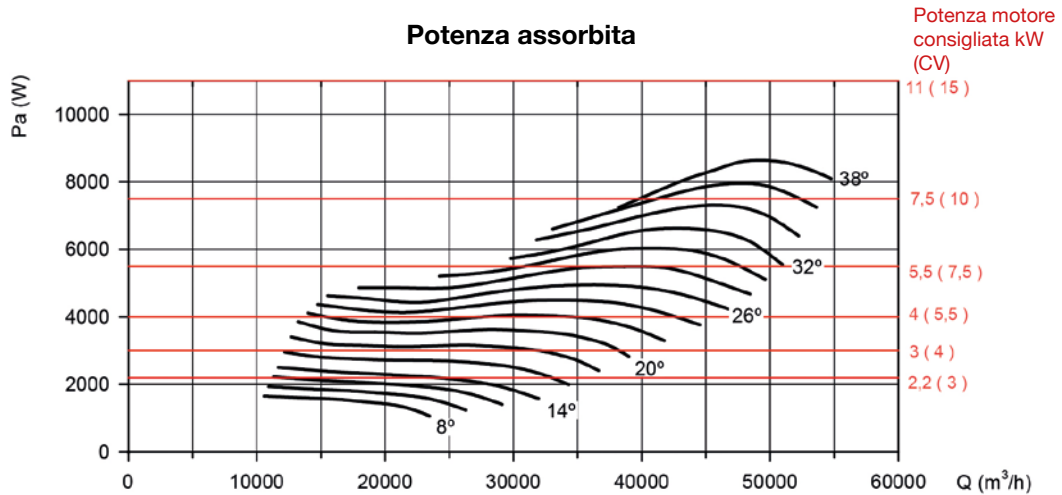

Curve caratteristiche

Q= Portata in m³/h, m³/s e cfm

Pe= Pressione statica in mmH₂O, Pa e inwg

Diametro girante in cm: 125

Numero di poli del motore: 4

Numero di pale: 6

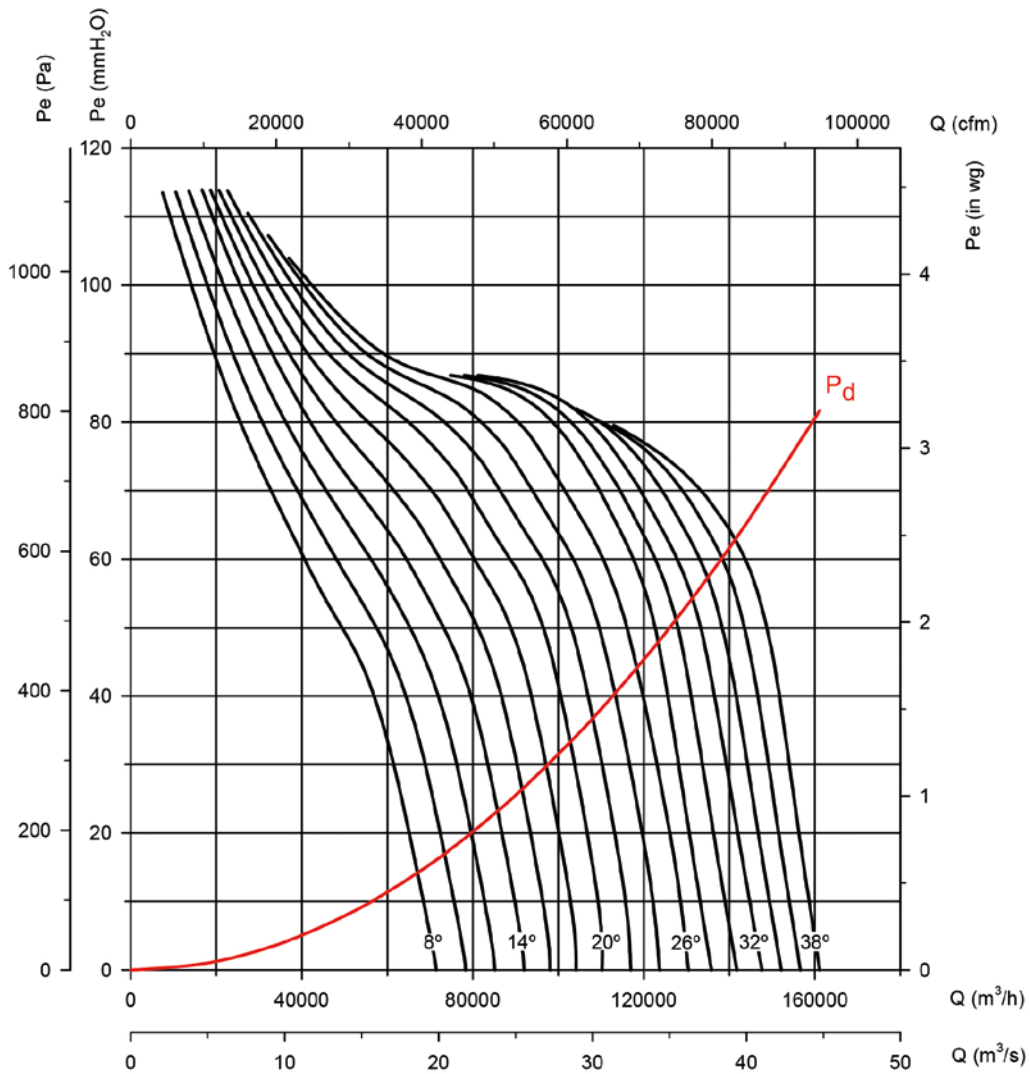

Potenza assorbita

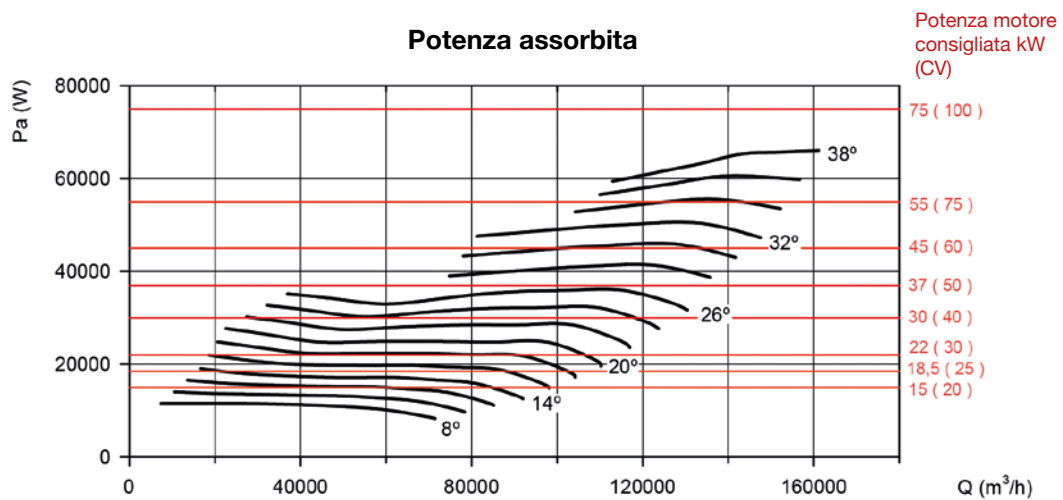

Curve caratteristiche

Q= Portata in m³/h, m³/s e cfm

Pe= Pressione statica in mmH₂O, Pa e inwg

Diametro girante in cm: 125

Numero di poli del motore: 4

Numero di pale: 9

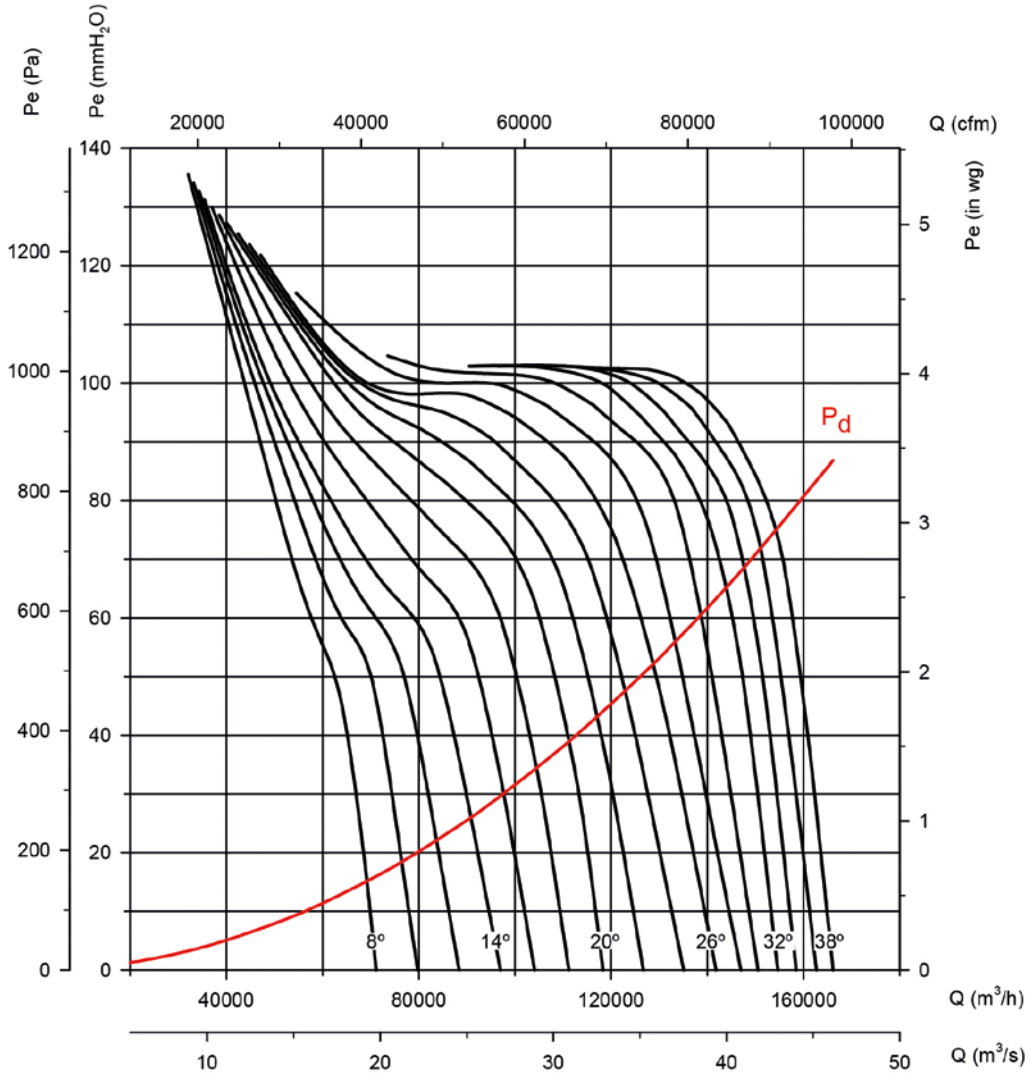

Potenza assorbita

Potenza motore consigliata kW (CV)

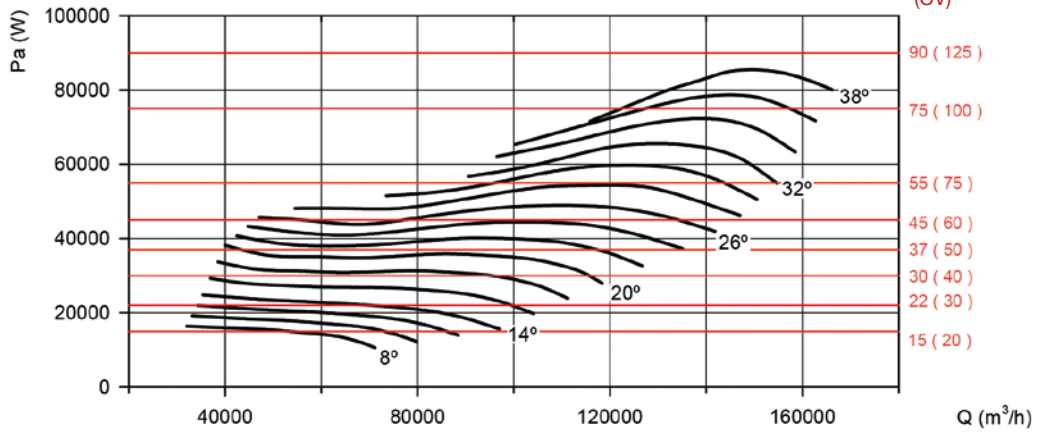

Curve caratteristiche

Q= Portata in m³/h, m³/s e cfm

Pe= Pressione statica in mmH₂O, Pa e inwg

Diametro girante in cm: 125

Numero di poli del motore: 4

Numero di pale: 12

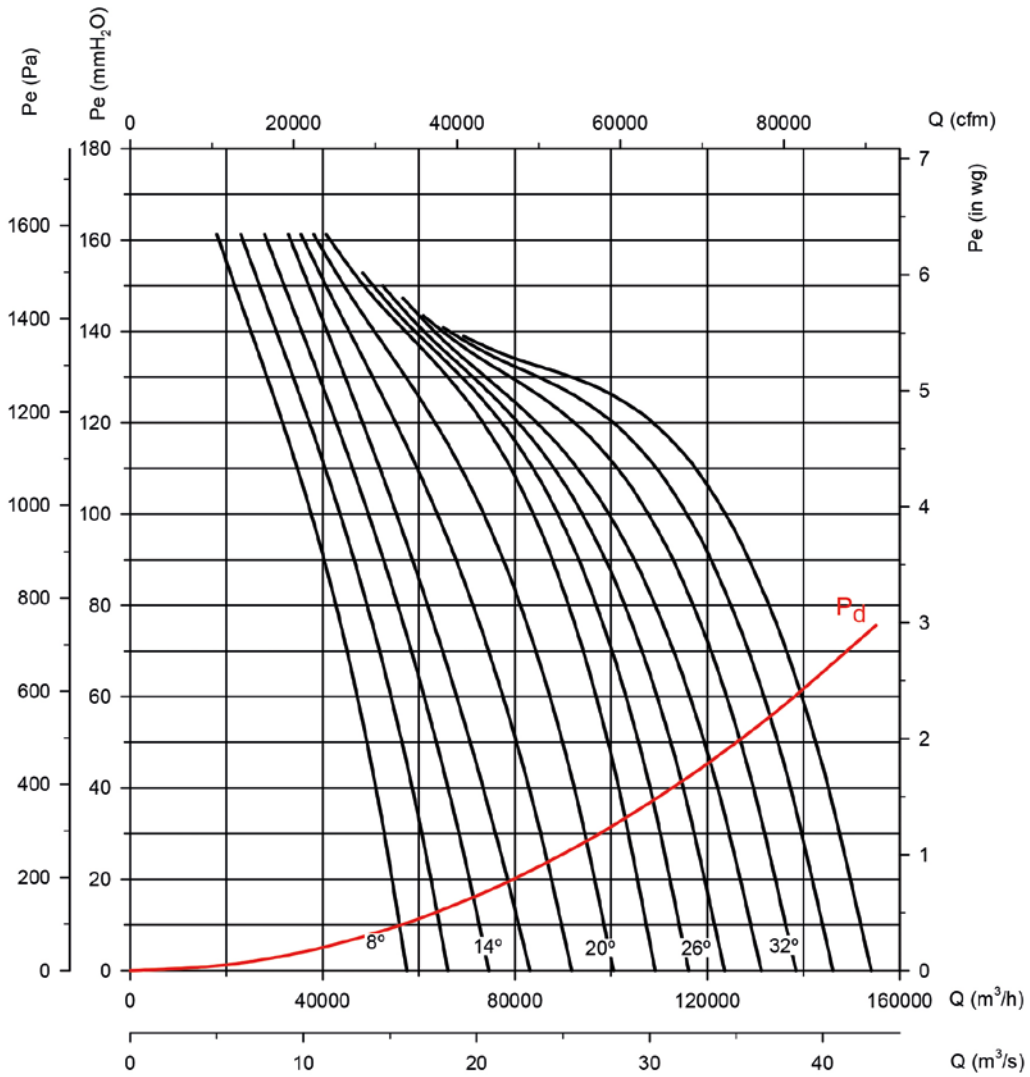

Potenza assorbita

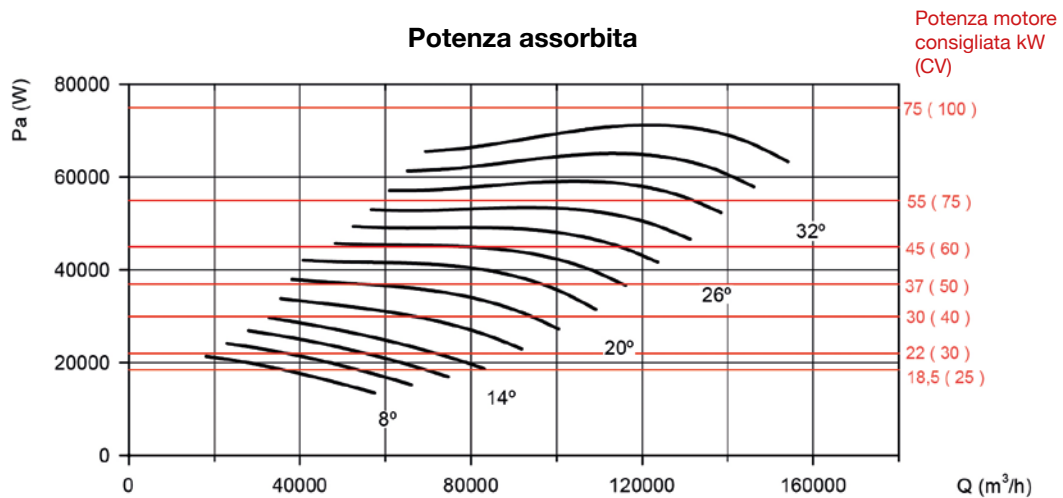

Curve caratteristiche

Q= Portata in m³/h, m³/s e cfm

Pe= Pressione statica in mmH₂O, Pa e inwg

Diametro girante in cm: 125

Numero di poli del motore: 6

Numero di pale: 6

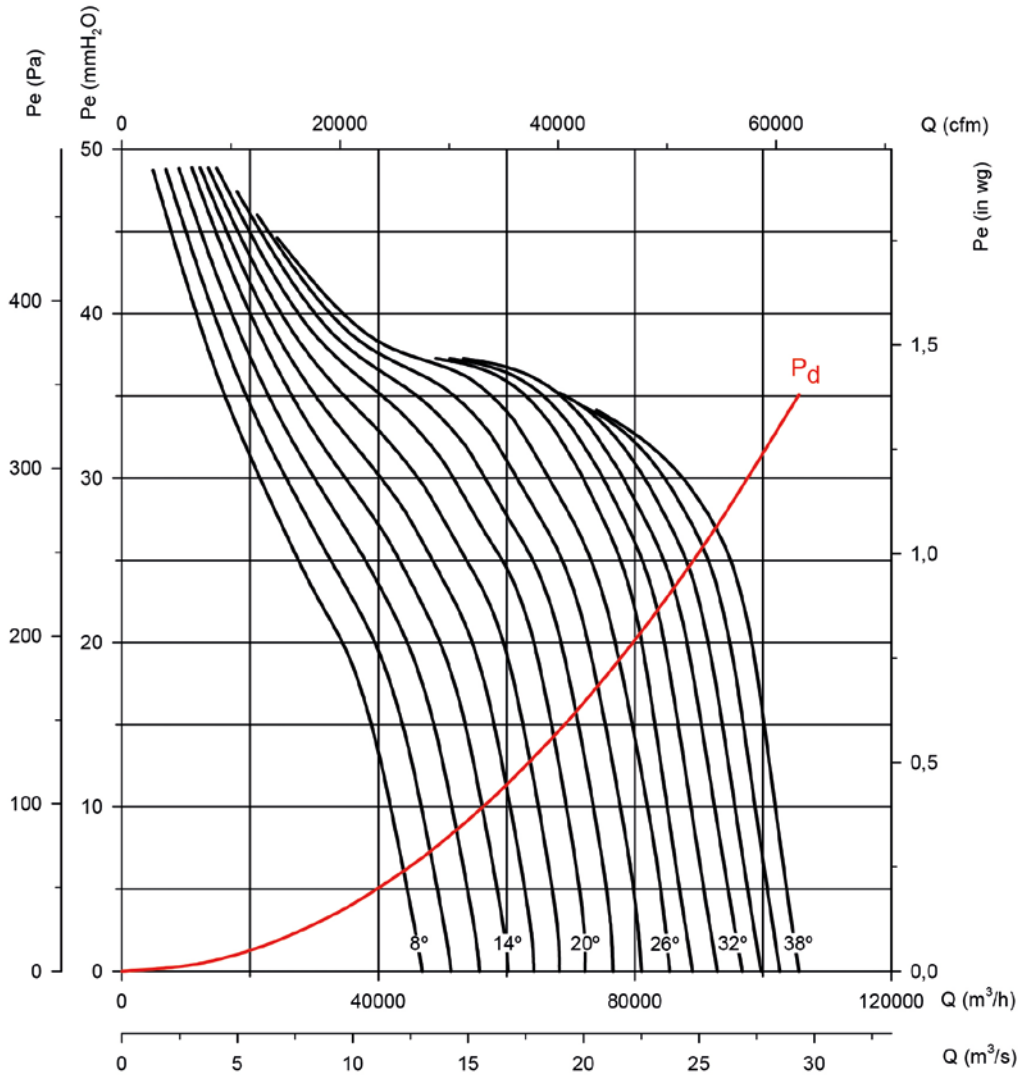

Potenza assorbita

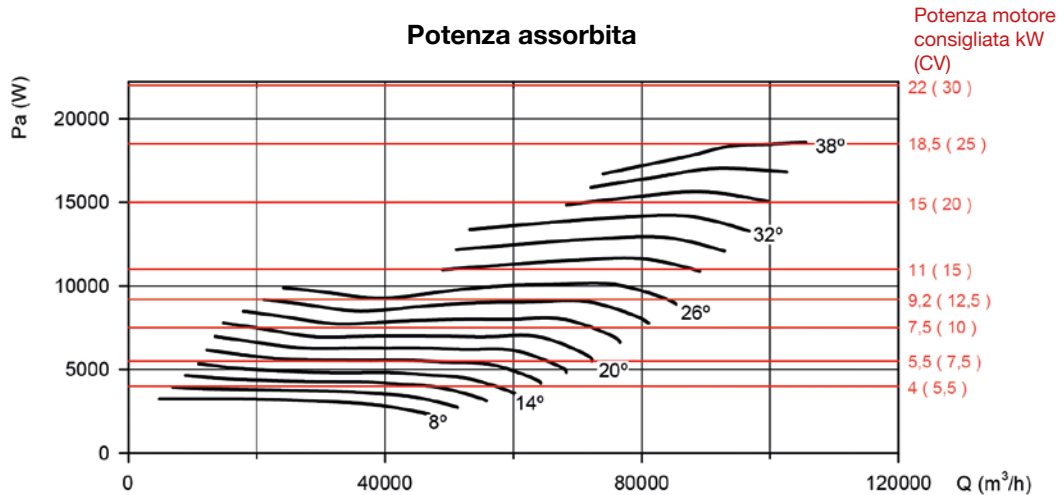

Curve caratteristiche

Q= Portata in m³/h, m³/s e cfm

Pe= Pressione statica in mmH₂O, Pa e inwg

Diametro girante in cm: 125

Numero di poli del motore: 6

Numero di pale: 9

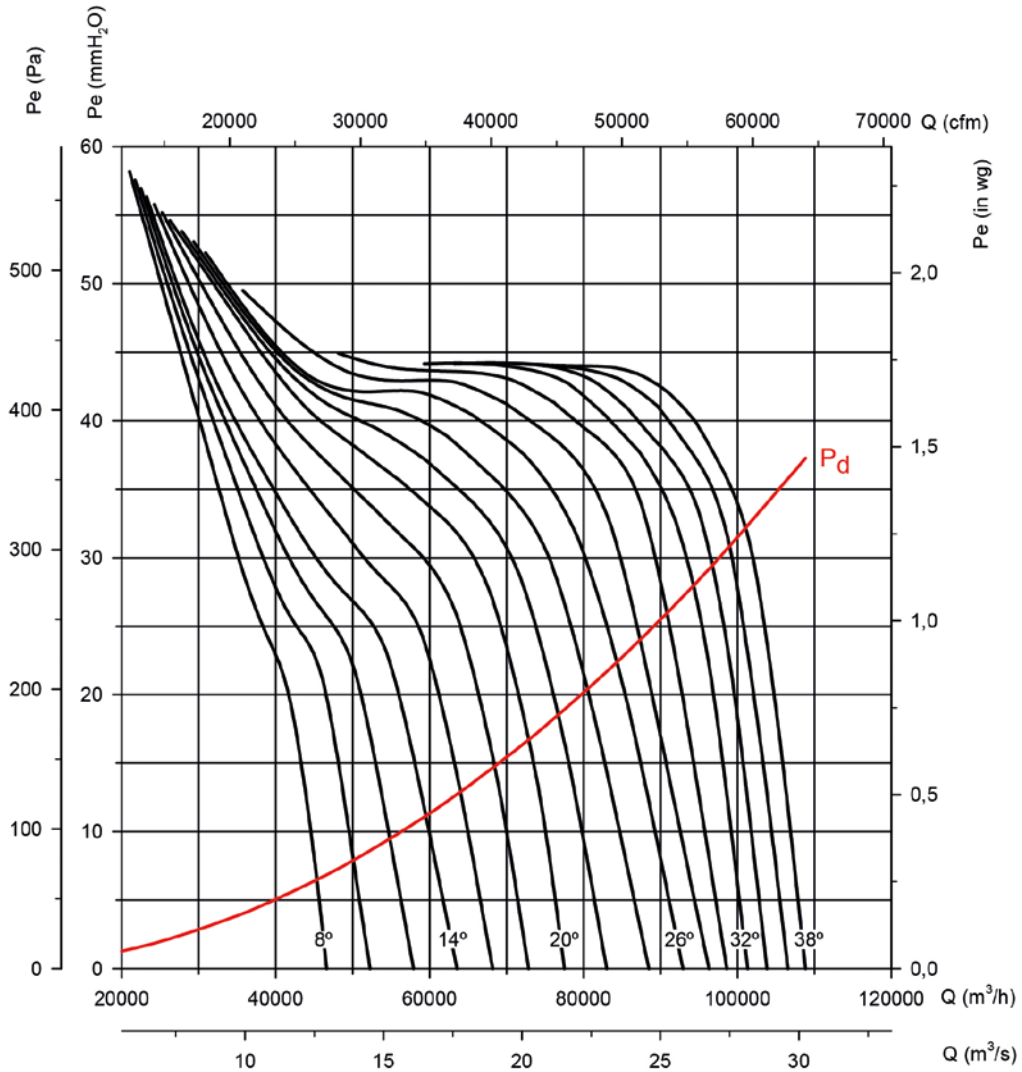

Potenza assorbita

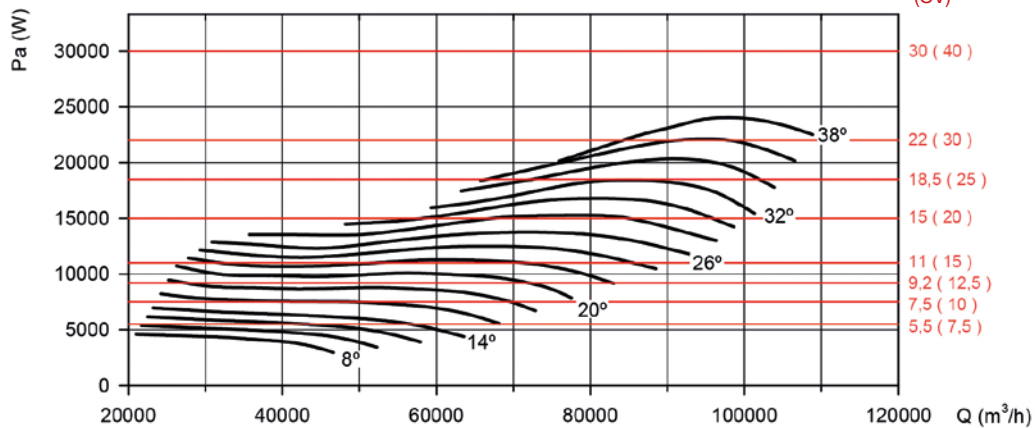

Curve caratteristiche

Q= Portata in m³/h, m³/s e cfm

Pe= Pressione statica in mmH₂O, Pa e inwg

Diametro girante in cm: 125

Numero di poli del motore: 6

Numero di pale: 12

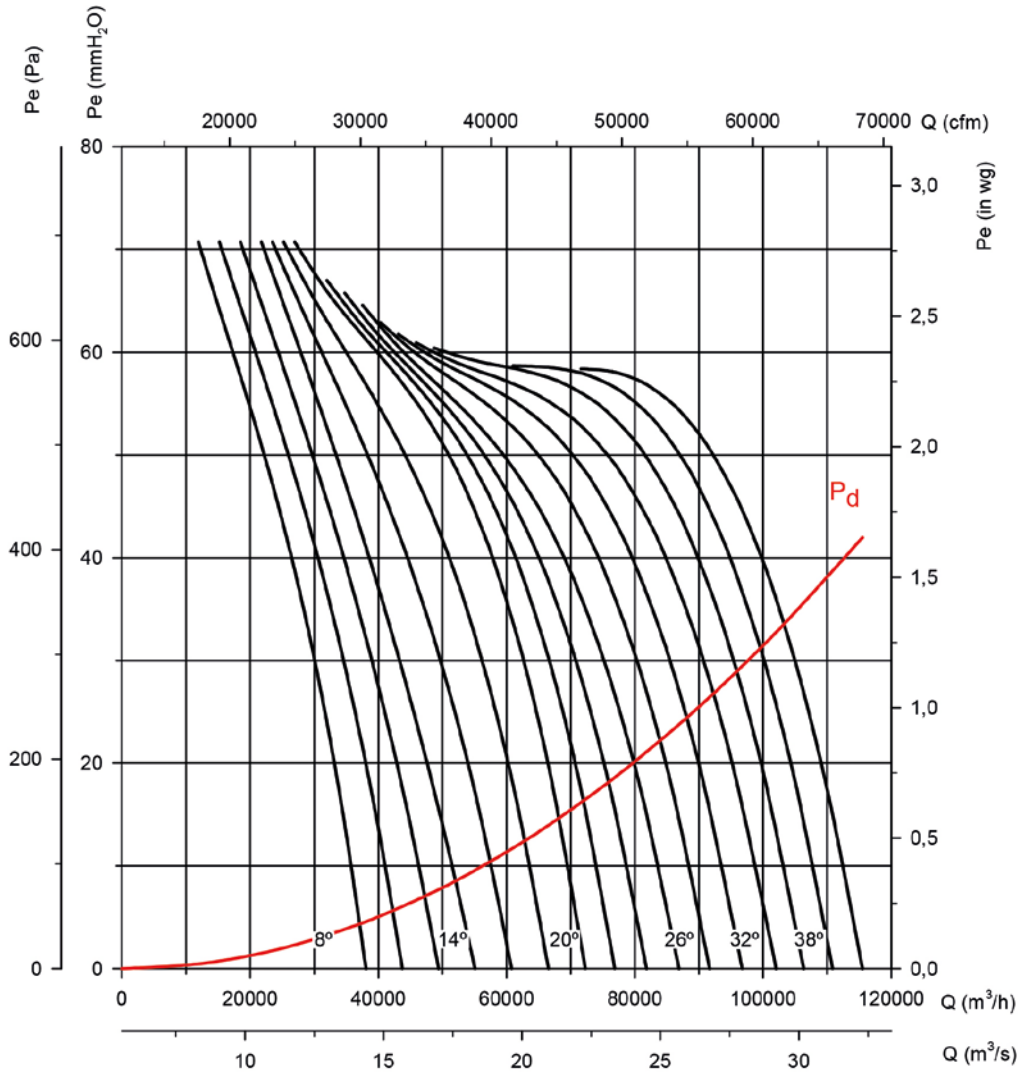

Potenza assorbita

Potenza motore consigliata kW (CV)

