

TSA



Ventilatori centrifughi a semplice aspirazione a trasmissione, con uscita ad asse e girante con pale curve in avanti



Ventilatore:

- Rivestimento in lamiera di acciaio galvanizzato.
- Girante con pale curve in avanti in lamiera di acciaio galvanizzato.
- Temperatura dell'aria da movimentare: -25 °C +85 °C.

Finitura:

- Lamiera di acciaio galvanizzato.

Esempio di codice per ordine

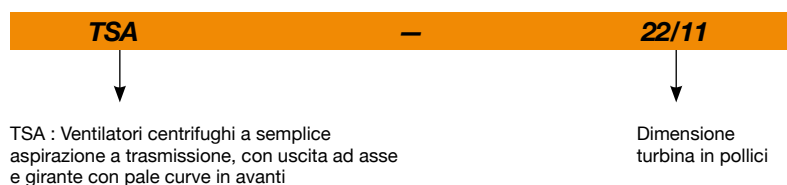

Caratteristiche tecniche

Modello	Velocità max.	Potenza installata max.	Portata massima (m ³ /h)	Temperatura dell'aria (°C)		Peso circa (Kg)
	(giri/min)	(kW)		min.	max.	
TSA-12/6	1600	2,2	5020	-25	85	18
TSA-15/7	1100	3,0	7600	-25	85	23
TSA-18/9	1000	4,0	10990	-25	85	33
TSA-20/10	900	5,5	15760	-25	85	71
TSA-22/11	1000	18,5	27030	-25	85	80
TSA-25/13	900	18,5	34050	-25	85	93
TSA-30/14	600	18,5	41400	-25	85	125



Erp. (Energy Related Products)

Informazioni sulla direttiva 2009/125/CE scaricabili dal sito web di SODECA o da QuickFan Selector.

Dimensioni in mm

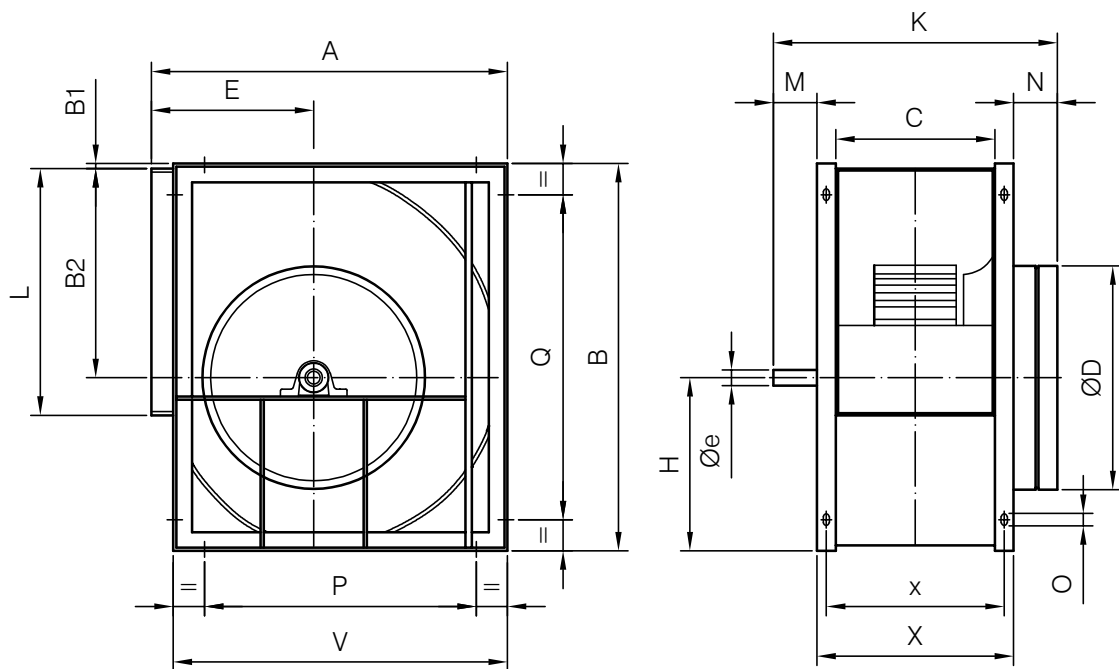

	A	B	B1	B2	C	øD	E	øe	H	K	L	M	N	O	P	Q	V	X	x
TSA-12/6	498	532	-	290	210	317	230	25	242	435	345	75	90	9x17	324	324	468	270	242
TSA-15/7	583	632	-	348	269	400	265	25	284	494	404	75	90	9x17	406	406	553	329	301
TSA-18/9	694	756	-	415	301	480	323	25	341	526	482	75	90	9x17	520	608	664	361	333
TSA-20/10	843	963	35	523	330	582	375	35	440	620	603	100	110	9x17	646	811	798	410	370
TSA-22/11	913	1046	35	569	358	625	400	35	477	648	693	100	110	9x17	716	894	868	438	398
TSA-25/13	998	1161	35	642	412	703	423	35	519	701	793	100	110	9x17	801	1009	953	492	452
TSA-30/14	1206	1400	35	776	474	804	515	40	624	764	933	100	110	9x17	1009	1248	1161	554	514

Accessori



INT



VSD3/A-RFT
- VSD1/A-RFM



AET



VIS



ACE ACE/400



TEJ

Curve caratteristiche

Q= Portata in m³/h, m³/s e cfm

Pe= Pressione statica in mmH₂O, Pa e inWG

I livelli sonori indicati sulle curve rappresentano pressioni in aspirazione, misurate in campo libero a una distanza di 3 m.

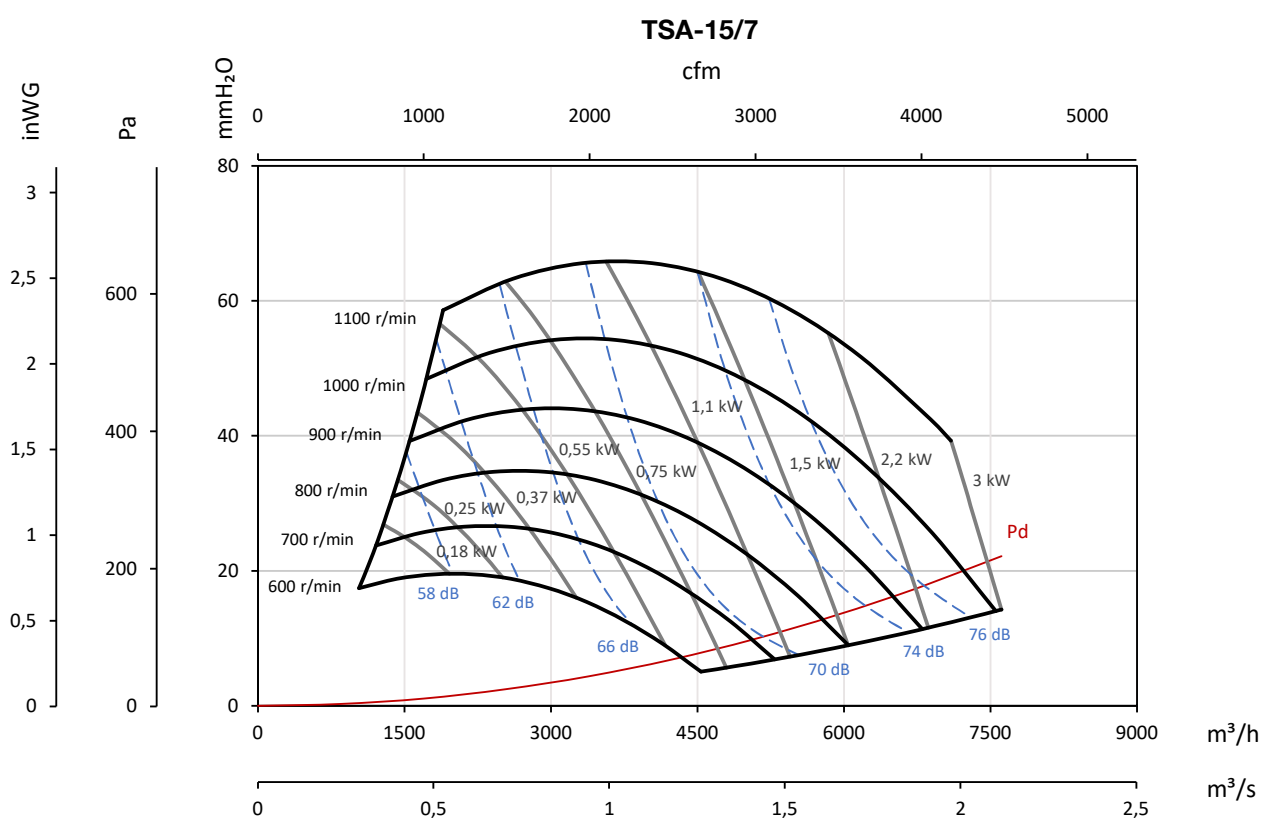
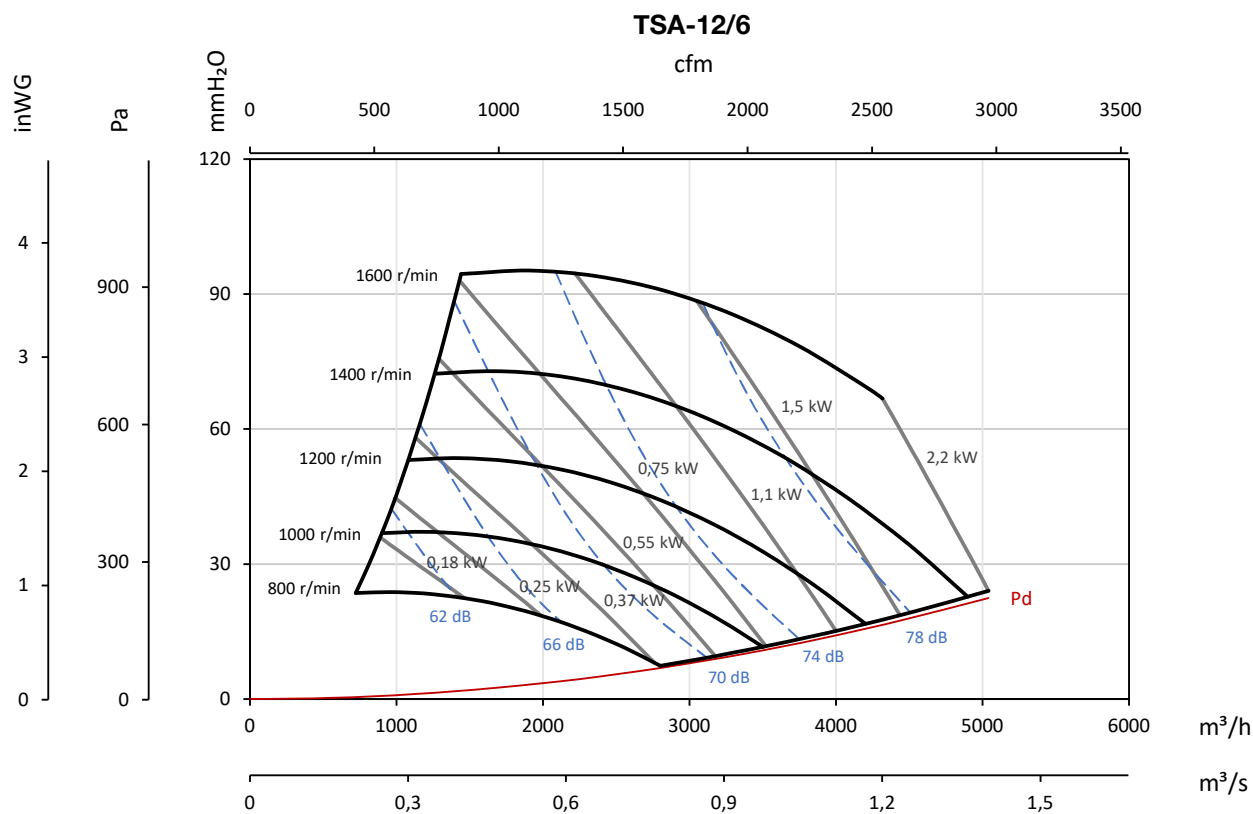

Curve caratteristiche

Q= Portata in m³/h, m³/s e cfm

Pe= Pressione statica in mmH₂O, Pa e inwg

I livelli sonori indicati sulle curve rappresentano pressioni in aspirazione, misurate in campo libero a una distanza di 3 m.

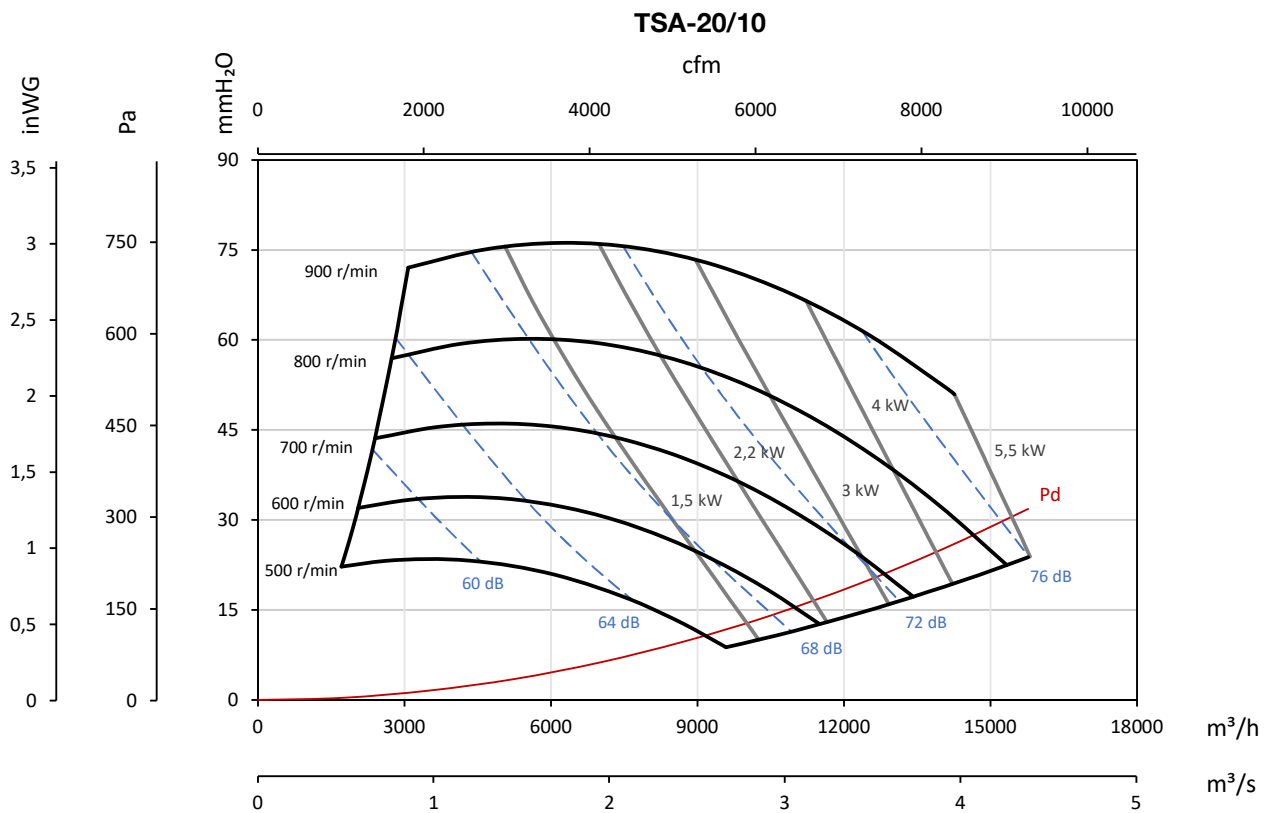
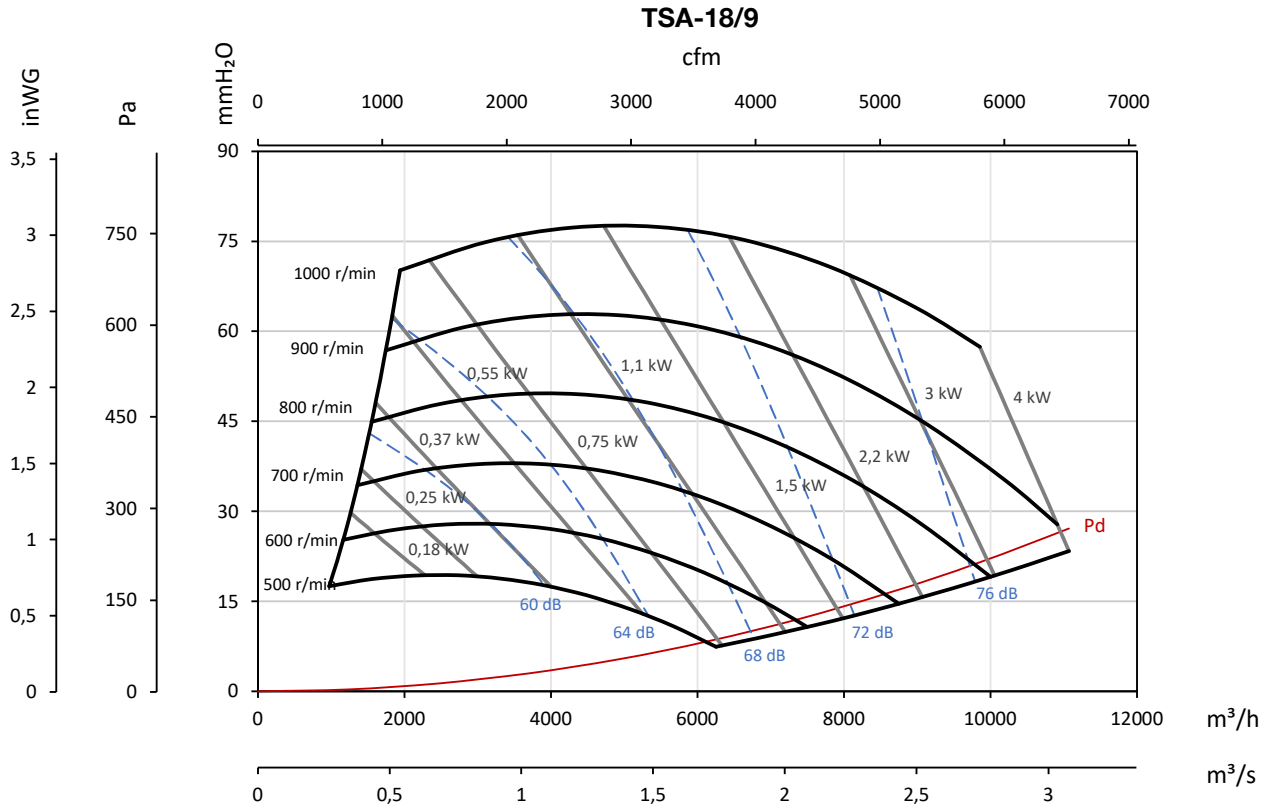

Curve caratteristiche

Q= Portata in m³/h, m³/s e cfm

Pe= Pressione statica in mmH₂O, Pa e inwg

I livelli sonori indicati sulle curve rappresentano pressioni in aspirazione, misurate in campo libero a una distanza di 3 m.

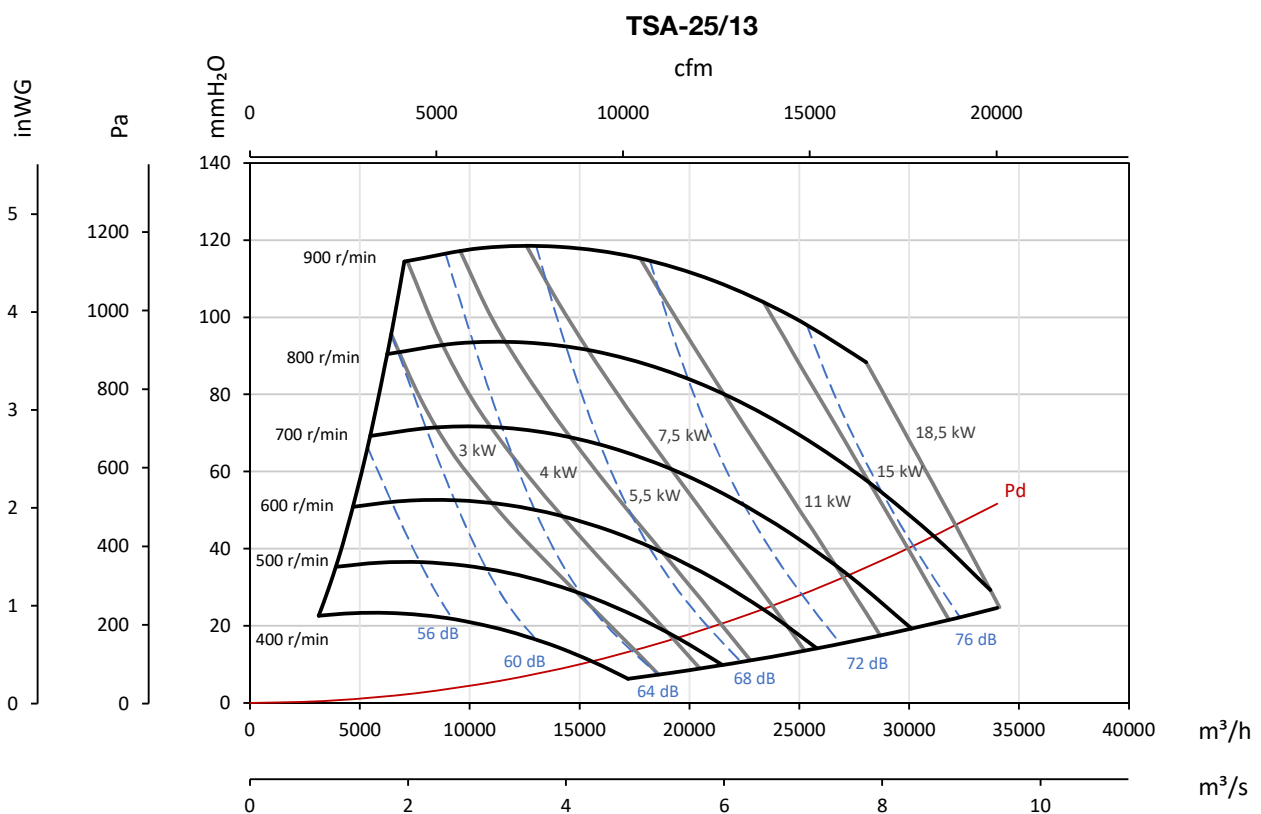
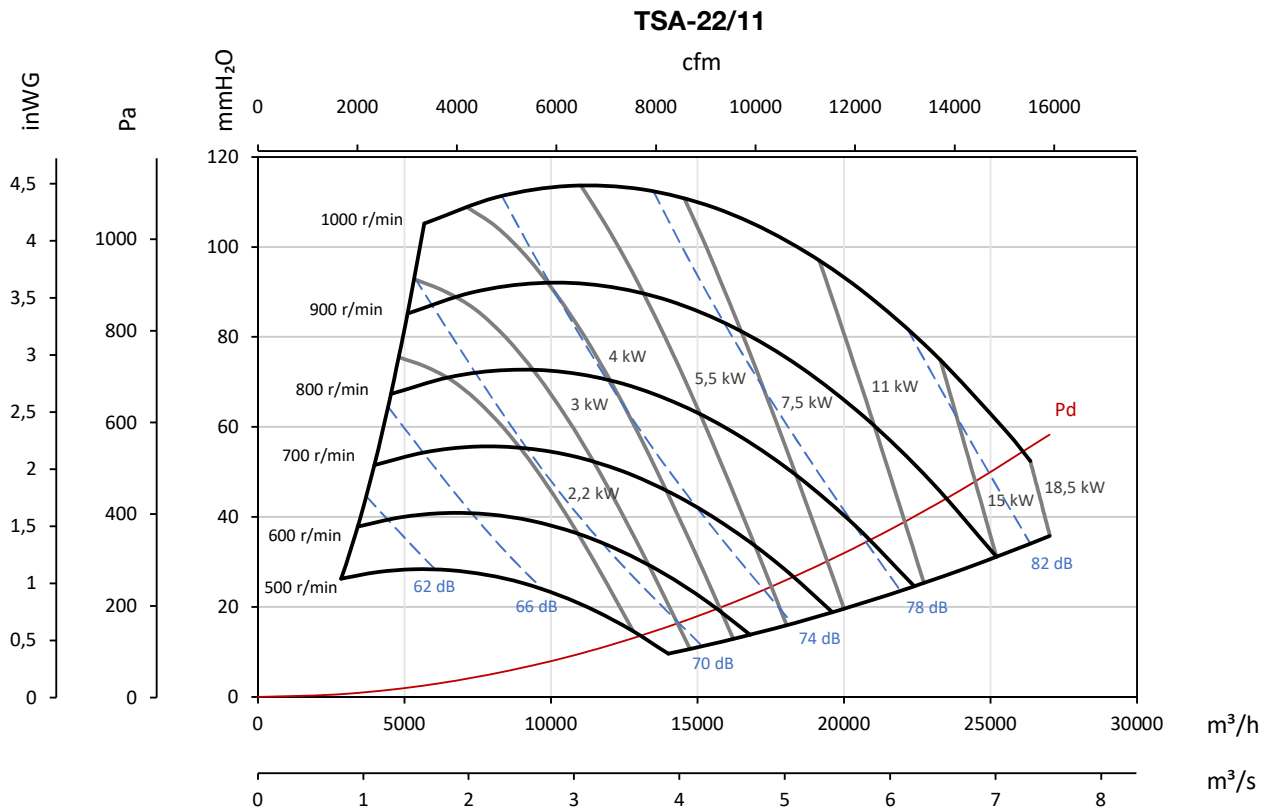

Curve caratteristiche

Q= Portata in m³/h, m³/s e cfm

Pe= Pressione statica in mmH₂O, Pa e inwg

I livelli sonori indicati sulle curve rappresentano pressioni in aspirazione, misurate in campo libero a una distanza di 3 m.

