

# TCR/R/EW



**Estrattori centrifughi 400 °C/2h con girante con pale rovesce dotati di motore asincrono ad alto rendimento IE3 regolabile elettronicamente**



**VARIATORE VELOCITÀ**  
VSD: Variatore elettronico di velocità.  
VSD1/A-RFM  
VSD3/A-RFT  
Fornitura su richiesta

**CONTROLLO**  
Fornito come accessorio opzionale

**ALIMENTAZIONE**  
VSD1/A-RFM:  
220-240 V 50/60 Hz  
VSD3/A-RFT:  
380-415 V 50/60 Hz

Estrattori centrifughi 400 °C/2h per il funzionamento fuori da zone a rischio incendio, a semplice aspirazione e di elevata robustezza, dotati di girante con pale rovesce e motore asincrono ad alto rendimento IE3 regolabile elettronicamente.

#### Ventilatore:

- Rivestimento in lamiera di acciaio.
- Girante con pale rovesce in lamiera di acciaio di elevata robustezza con vernice antitermica.
- Omologazione secondo la norma EN 12101-3.

#### Motore:

- Nuovi motori AC sincroni ad alto rendimento (IE3).
- Provvisti di cuscinetti a sfere a lunga durata. Grado di protezione IP55.
- Trifase 230/400 V 50 Hz (fino a 4 kW) e 400/690 V 50 Hz (potenze superiori a 4 kW).
- Temperatura massima dell'aria da movimentare: Servizio S1 -25 °C +250 °C in continuo. Servizio S2 300 °C/2h e 400 °C/2h.

#### Variatore elettronico di velocità:

- Velocità regolabile mediante segnale 0-10 V o controllo automatico PI integrato nel variatore.

- Variatore elettronico con numerose opzioni di configurazione, 2 ingressi analogici, 2 ingressi digitali, 1 uscita relè e 1 uscita a scelta tra analogica e digitale.
- Possibilità di connessione ai bus di campo MODBUS e CAN Open.
- Variatore elettronico di facile installazione all'esterno della zona di lavoro. Grazie alla guida DIN di cui è dotato, può essere installato in quadri comandi riducendo al minimo le connessioni necessarie.
- Fornito precablato con cavo schermato, in conformità alla direttiva EMC 2014/30/UE.
- Disponibili con ingresso monofase 220-240 V 50/60 Hz fino a 3 CV (tipo VSD1/A-RFM) o trifase 380-415 V 50/60 Hz (tipo VSD3/A-RFT). Grado di protezione standard IP20. Grado di protezione IP66 fino a 10 CV su richiesta.
- Temperatura di esercizio (VSD): -25 °C +50 °C.

#### Finitura:

- Anticorrosiva in resina di poliestere polimerizzata a 190 °C, previo sgrassaggio con trattamento nanotecnologico senza fosfati.

## Codice ordine ventilatore

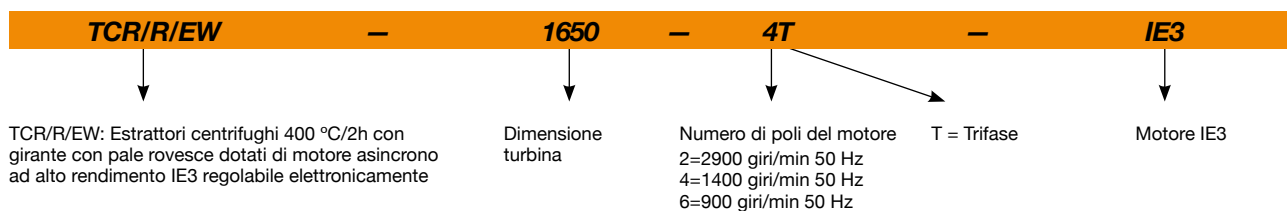

## Codice ordine con fornitura del variatore elettronico (VSD) compreso

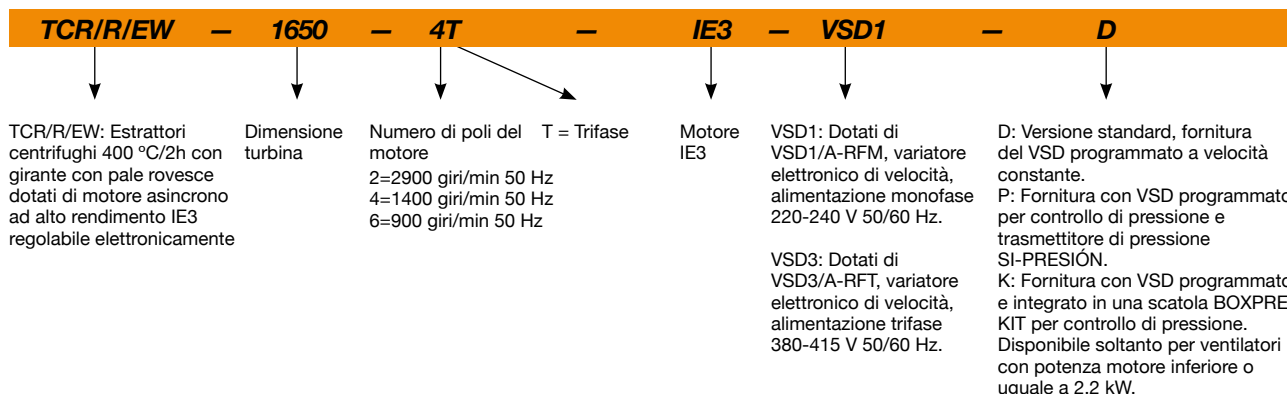

## Caratteristiche tecniche

Modello	Velocità min/max  (giri/min)	VSD monofase 230 V 50/60 Hz		VSD trifase 400 V 50/60 Hz		Intensità massima motore 50 Hz (A)			Potenza installata  (kW)	Portata min/max  (m³/h)	Livello di pressione sonora min/max  dB (A)	Peso circa  (Kg)
		Intensità massima di ingresso (A)	Modello VSD	Intensità massima di ingresso (A)	Modello VSD	230V	400V	690V				
TCR/R/EW-1240-2T-IE3	1160/2900	-	-	9,44	VSD3/A-RFT-5.5	13,00	7,50	-	4,00	4440 / 11110	62/82	93
TCR/R/EW-1240-4T-IE3	570/1420	8,32	VSD1/A-RFM-1	2,31	VSD3/A-RFT-1	2,82	1,62	-	0,75	2330 / 5830	47/67	71
TCR/R/EW-1445-2T-IE3	1170/2935	-	-	17,45	VSD3/A-RFT-10	-	13,90	8,06	7,50	6620 / 16560	65/85	126
TCR/R/EW-1445-4T-IE3	580/1455	11,87	VSD1/A-RFM-2	3,30	VSD3/A-RFT-2	4,07	2,34	-	1,10	3240 / 8100	50/70	93
TCR/R/EW-1650-4T-IE3	580/1440	15,78	VSD1/A-RFM-2	4,38	VSD3/A-RFT-2	5,41	3,11	-	1,50	4240 / 10600	52/72	114
TCR/R/EW-1650-6T-IE3	380/940	8,69	VSD1/A-RFM-1	2,41	VSD3/A-RFT-1	3,36	1,93	-	0,75	2980 / 7450	42/62	111
TCR/R/EW-1856-4T-IE3	580/1440	-	-	7,20	VSD3/A-RFT-5.5	10,70	6,15	-	3,00	6100 / 15240	58/78	152
TCR/R/EW-1856-6T-IE3	380/945	12,43	VSD1/A-RFM-2	3,45	VSD3/A-RFT-2	4,68	2,69	-	1,10	4020 / 10040	50/70	145
TCR/R/EW-2063-4T-IE3	590/1465	-	-	12,81	VSD3/A-RFT-7.5	-	10,30	5,97	5,50	9800 / 24490	60/80	225
TCR/R/EW-2063-6T-IE3	380/950	16,64	VSD1/A-RFM-2	4,62	VSD3/A-RFT-2	6,43	3,70	-	1,50	6460 / 16140	50/70	209
TCR/R/EW-2271-4T-IE3	590/1470	-	-	25,10	VSD3/A-RFT-15	-	21,40	12,40	11,00	13900 / 34760	62/82	315
TCR/R/EW-2271-6T-IE3	390/970	-	-	7,39	VSD3/A-RFT-5.5	12,00	6,91	-	3,00	9200 / 23000	57/77	280



## Erp. (Energy Related Products)

Informazioni sulla direttiva 2009/125/CE scaricabili dal sito web di SODECA o da QuickFan Selector.

## Caratteristiche acustiche

I valori indicati vengono determinati tramite le misurazioni del livello di pressione e di potenza sonora in dB(A) ottenute in campo libero a una distanza equivalente a due volte l'apertura del ventilatore più il diametro della turbina, con un minimo di 1,5 metri.

Spettro di potenza sonora Lw(A) in dB(A) per banda di frequenza in Hz

	63	125	250	500	1000	2000	4000	8000		63	125	250	500	1000	2000	4000	8000
TCR/R/EW-1240-2T	68	83	81	93	90	94	96	83	TCR/R/EW-1856-4T	69	78	91	87	90	91	85	71
TCR/R/EW-1240-4T	56	40	76	79	79	80	70	59	TCR/R/EW-1856-6T	61	69	81	83	80	81	71	60
TCR/R/EW-1445-2T	73	85	83	95	93	97	99	89	TCR/R/EW-2063-4T	80	85	91	93	91	88	81	73
TCR/R/EW-1445-4T	59	72	78	83	80	83	78	64	TCR/R/EW-2063-6T	69	70	82	82	81	83	73	63
TCR/R/EW-1650-4T	64	74	82	84	83	85	76	66	TCR/R/EW-2271-4T	79	80	89	92	94	95	91	78
TCR/R/EW-1650-6T	53	65	72	77	73	69	62	54	TCR/R/EW-2271-6T	73	73	87	86	90	90	79	68

## Orientamenti

Fornitura standard LG 270

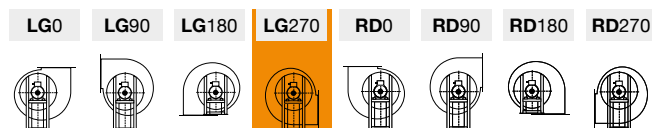

## Dimensioni in mm

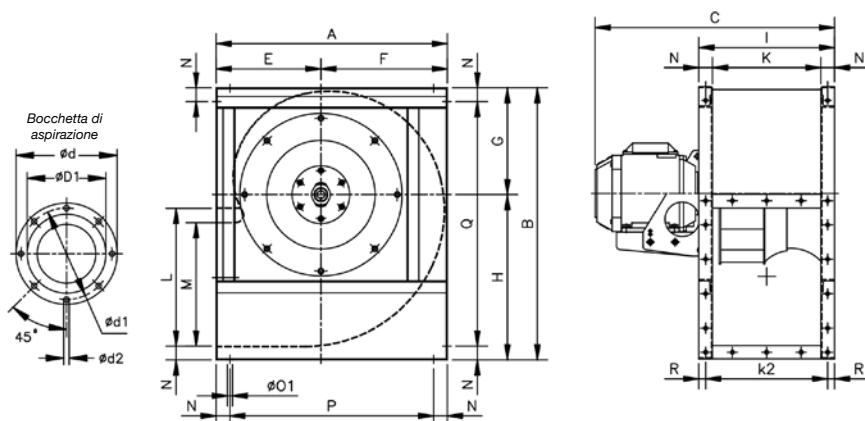

	A	B	C	Ød	Ød1	ØD1*	Ød2	E	F	G	H	I	K	k2	L	M	N	Ø01	P	Q	R
TCR/R/EW-1240-2T	673	790	734	472	444	319	M8	305	368	310	480	395	315	355	400	358,5	40	11	593	710	20
TCR/R/EW-1240-4T	673	790	634	472	444	319	M8	305	368	310	480	395	315	355	400	358,5	40	11	593	710	20
TCR/R/EW-1445-2T	765	880	827	524	494	358	M10	350	415	340	540	445	355	405	450	407	45	11	675	790	20
TCR/R/EW-1445-4T	765	880	699	524	494	358	M10	350	415	340	540	445	355	405	450	407	45	11	675	790	20
TCR/R/EW-1650-4T	832	970	953	582	555	401	M10	375	457	378	592	490	400	450	500	446	45	13	742	880	20
TCR/R/EW-1650-6T	832	970	772,5	582	555	401	M10	375	457	378	592	490	400	450	500	446	45	13	742	880	20
TCR/R/EW-1856-4T	925	1084	880	645	615	457	M10	415	510	426	658	550	450	500	560	493	50	13	825	984	25
TCR/R/EW-1856-6T	925	1084	825	645	615	457	M10	415	510	426	658	550	450	500	560	493	50	13	825	984	25
TCR/R/EW-2063-4T	1037	1218	981	720	688	507	M10	465	572	477	741	620	500	560	630	530	60	13	917	1098	30
TCR/R/EW-2063-6T	1037	1218	932	720	688	507	M10	465	572	477	741	620	500	560	630	530	60	13	917	1098	30
TCR/R/EW-2271-4T	1173	1375	1197	800	768	575	M10	525	648	538	837	690	560	625	710	603,5	65	13	1043	1245	32,5
TCR/R/EW-2271-6T	1173	1375	1095	800	768	575	M10	525	648	538	837	690	560	625	710	603,5	65	13	1043	1245	32,5

\* Diametro nominale raccomandato per le tubazioni

## Bocchetta di mandata

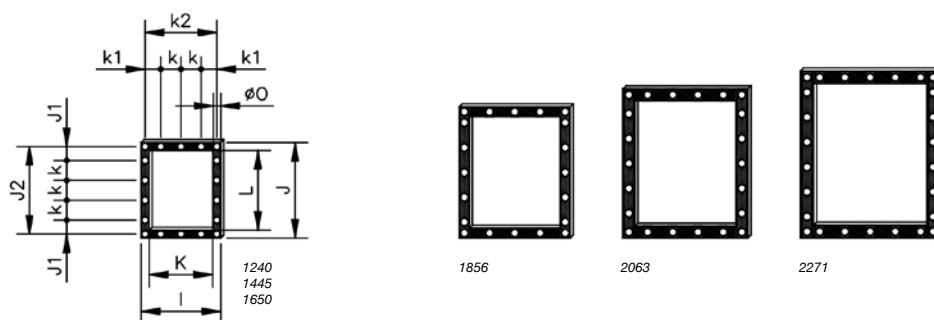

	I	J	J1	J2	K	k3	k1	k2	L	Ø0
TCR/R/EW-1240	395	480	70	440	315	100	77,5	355	400	13
TCR/R/EW-1445	445	540	99	498	355	100	102,5	405	450	11
TCR/R/EW-1650	490	590	87,5	550	400	125	100	450	500	13
TCR/R/EW-1856	550	660	55	610	450	125	125	500	560	13
TCR/R/EW-2063	620	750	95	690	500	125	92,5	560	630	13
TCR/R/EW-2271	690	840	75	778	560	125	62,5	625	710	13

## Curve caratteristiche

Q= Portata in m<sup>3</sup>/h, m<sup>3</sup>/s e cfm

Pe= Pressione statica in mmH<sub>2</sub>O, Pa e inwg

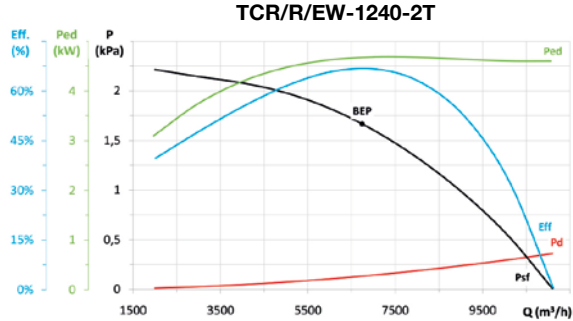

MC	EC	SR	Cc	$\eta_e$ (%)*	N	[kW]	[m <sup>3</sup> /h]	[Pa]	[rpm]	VSD
A	S	1,02	1,04	69,6%	73,1	4,675	6744	1667,2	2901	NECESSARY

\* $\eta_e$  (%) = Eff. (%) x Cc

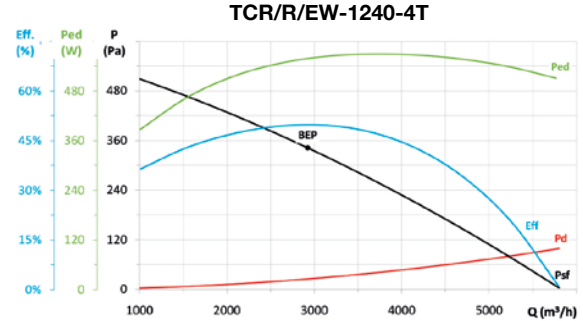

MC	EC	SR	Cc	$\eta_e$ (%)*	N	[kW]	[m <sup>3</sup> /h]	[Pa]	[rpm]	VSD
A	S	1,00	1,11	55,1%	68,2	0,558	2924	342,3	1453	NECESSARY

\* $\eta_e$  (%) = Eff. (%) x Cc

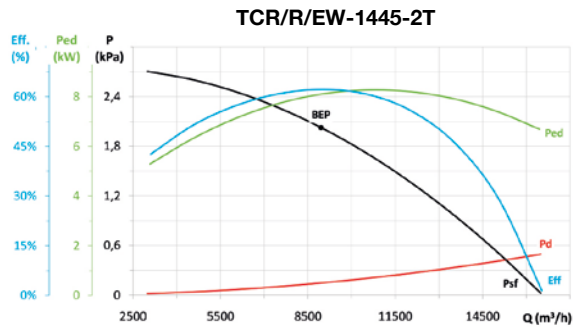

MC	EC	SR	Cc	$\eta_e$ (%)*	N	[kW]	[m <sup>3</sup> /h]	[Pa]	[rpm]	VSD
A	S	1,02	1,04	64,6%	65,6	8,103	8951	2025,7	2939	NECESSARY

\* $\eta_e$  (%) = Eff. (%) x Cc

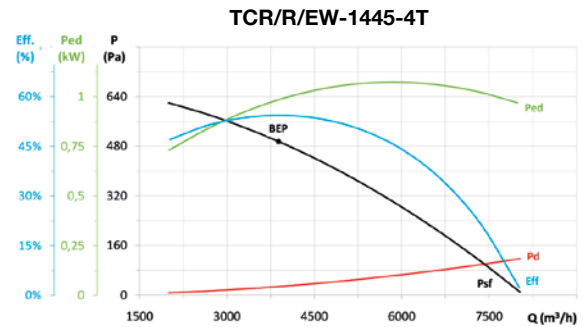

MC	EC	SR	Cc	$\eta_e$ (%)*	N	[kW]	[m <sup>3</sup> /h]	[Pa]	[rpm]	VSD
A	S	1,01	1,09	59,1%	69,7	0,983	3883	495,3	1468	NECESSARY

\* $\eta_e$  (%) = Eff. (%) x Cc

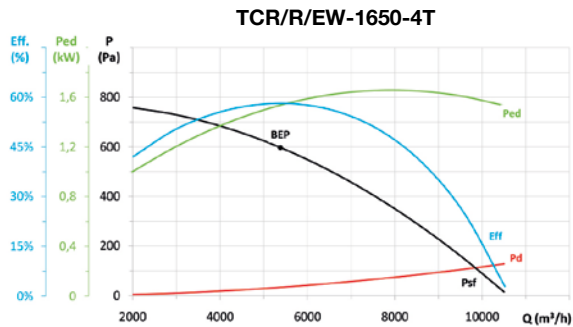

MC	EC	SR	Cc	$\eta_e$ (%)*	N	[kW]	[m <sup>3</sup> /h]	[Pa]	[rpm]	VSD
A	S	1,01	1,08	62,5%	71,1	1,535	5378	597,4	1449	NECESSARY

\* $\eta_e$  (%) = Eff. (%) x Cc

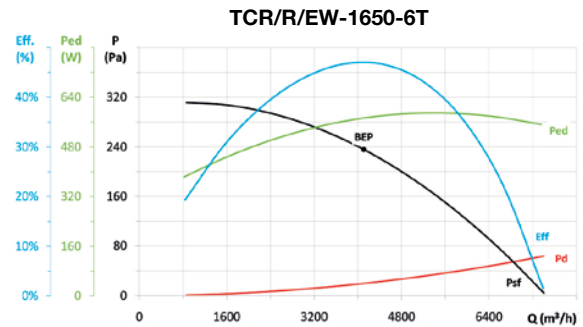

MC	EC	SR	Cc	$\eta_e$ (%)*	N	[kW]	[m <sup>3</sup> /h]	[Pa]	[rpm]	VSD
A	S	1,00	1,10	52,0%	65,0	0,572	4109	235,7	966	NECESSARY

\* $\eta_e$  (%) = Eff. (%) x Cc

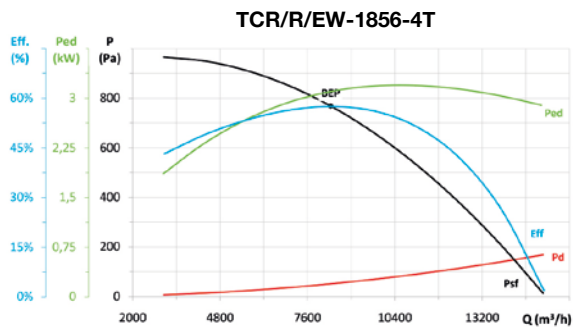

MC	EC	SR	Cc	$\eta_e$ (%)*	N	[kW]	[m <sup>3</sup> /h]	[Pa]	[rpm]	VSD
A	S	1,01	1,05	60,6%	65,9	3,096	8342	768,0	1448	NECESSARY

\* $\eta_e$  (%) = Eff. (%) x Cc

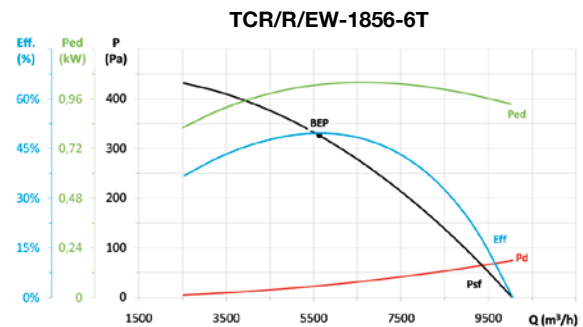

MC	EC	SR	Cc	$\eta_e$ (%)*	N	[kW]	[m <sup>3</sup> /h]	[Pa]	[rpm]	VSD
A	S	1,00	1,09	53,9%	64,3	1,028	5632	326,1	960	NECESSARY

\* $\eta_e$  (%) = Eff. (%) x Cc

## Curve caratteristiche

Q= Portata in m³/h, m³/s e cfm

Pe= Pressione statica in mmH₂O, Pa e inwg

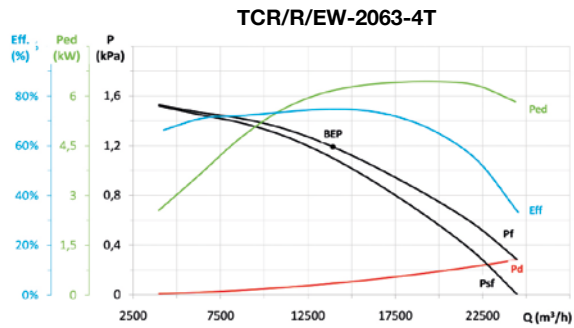

MC	EC	SR	Cc	$\eta_e$ (%)*	N	[kW]	[m³/h]	[Pa]	[rpm]	VSD
B	T	1,01	1,04	77,8%	80,0	6,161	13932	1190,7	1466	NECESSARY

\* $\eta_e$  (%) = Eff. (%) x Cc

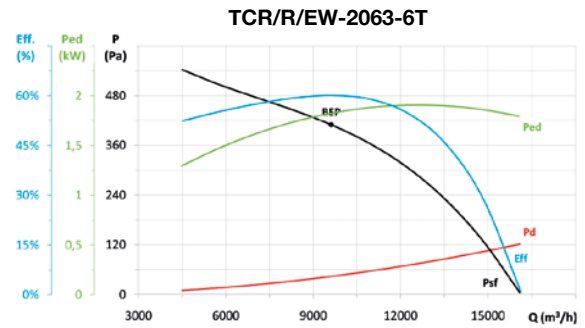

MC	EC	SR	Cc	$\eta_e$ (%)*	N	[kW]	[m³/h]	[Pa]	[rpm]	VSD
A	S	1,00	1,07	64,3%	72,1	1,822	9620	409,7	952	NECESSARY

\* $\eta_e$  (%) = Eff. (%) x Cc

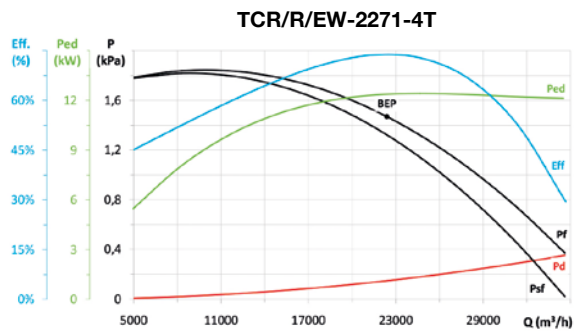

MC	EC	SR	Cc	$\eta_e$ (%)*	N	[kW]	[m³/h]	[Pa]	[rpm]	VSD
B	T	1,01	1,04	76,8%	76,7	12,369	22380	1469,6	1470	NECESSARY

\* $\eta_e$  (%) = Eff. (%) x Cc

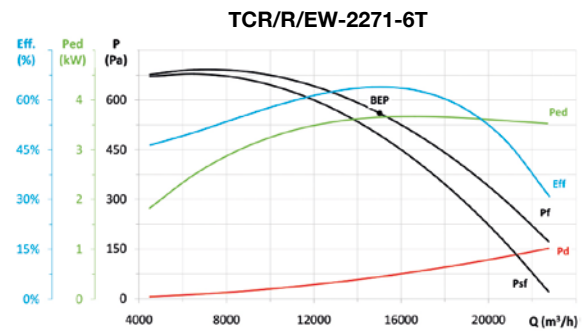

MC	EC	SR	Cc	$\eta_e$ (%)*	N	[kW]	[m³/h]	[Pa]	[rpm]	VSD
B	T	1,01	1,05	67,1%	71,7	3,654	15016	560,2	970	NECESSARY

\* $\eta_e$  (%) = Eff. (%) x Cc

## Accessori

