

THT/WALL

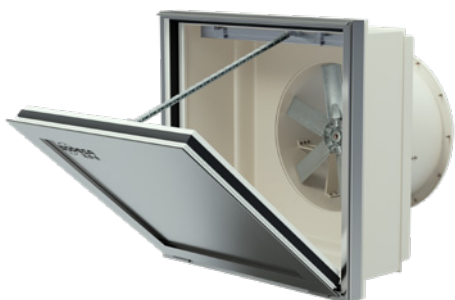

Estrattori dinamici da parete con paratoia ad apertura motorizzata, per l'evacuazione del fumo in caso di incendio, 400 °C/2h e 300 °C/2h



Estrattori dinamici da parete con apertura motorizzata, con possibilità di collegamento al condotto di estrazione. Appositamente progettati per un'evacuazione rapida ed efficiente di fumo e gas nocivi in caso di incendio. Per l'installazione in capannoni industriali, edifici commerciali o qualsiasi altro tipo di fabbricato. Omologazione dell'intero gruppo a norma EN-12101-3 con certificazione F400 e F300. Adatti anche per la ventilazione ambientale.

Ventilatore:

- Flangia di fissaggio alla parete e piede di supporto dell'anello assiale per una corretta e agevole installazione.
- Con certificazioni n. 0370-CPR-2823 (F400) e 0370-CPR-0973 (F300).
- Involucro tubolare di lamiera di acciaio con trattamento anticorrosione in resina di poliestere.
- Eliche a inclinazione variabile in alluminio pressofuso.
- Cavo di potenza schermato con protezione EMC.
- Direzione aria motore-elica.

Paratoia in alluminio estruso:

- Struttura altamente resistente per sopportare importanti cambiamenti climatici.
- Progettato per garantire una tenuta stagna contro le infiltrazioni dell'acqua.
- Profilo in alluminio con rottura del ponte termico.

- Plafoniera centrale e struttura dotate di isolante termico ad alte prestazioni.
- Resistività termica del gruppo inferiore a 0,89 W/m²-K.
- Interruttori di fine corsa in entrambe le posizioni (aperto e chiuso).
- Sistema di apertura manuale.

Motore:

- Motori in classe H per uso continuo S1 e di emergenza S2. Con cuscinetti a sfere, grado di protezione IP55, a 1 o 2 velocità in base al modello.
- Motori con rendimento IE3.
- Trifase 230/400 V 50 Hz (fino a 3 kW) e 400/690 V 50 Hz (potenze superiori a 3 kW).
- Temperatura massima dell'aria da movimentare: Servizio S1 -25 °C +40 °C in continuo, adatto anche per climi caldi con temperature fino a 50 °C. Servizio S2 300 °C/2h, 400 °C/2h.

Attuatore:

- Affidabilità per oltre 11.000 doppi cicli.
- Tensione di alimentazione 230 V AC 50/60 Hz.
- Temperatura di esercizio: -25 °C +60 °C.

Finitura paratoia:

- Anticorrosiva in alluminio estruso.
- Colore standard RAL 7016. Su richiesta, qualsiasi colore della cartella RAL.

Codice di ordinazione

Dalla dimensione 40 alla dimensione 100

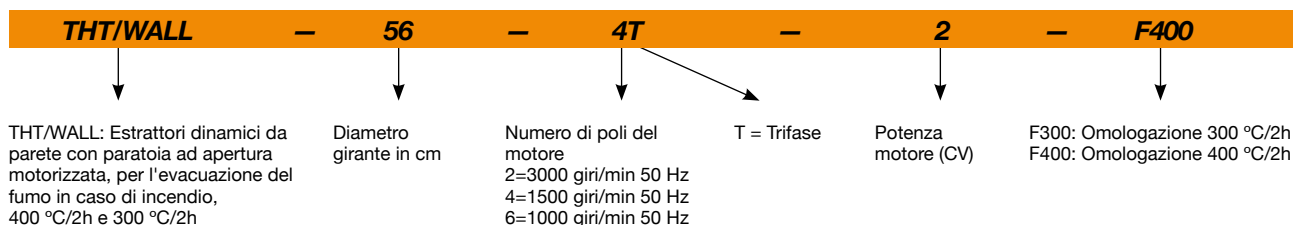

Dimensione 125

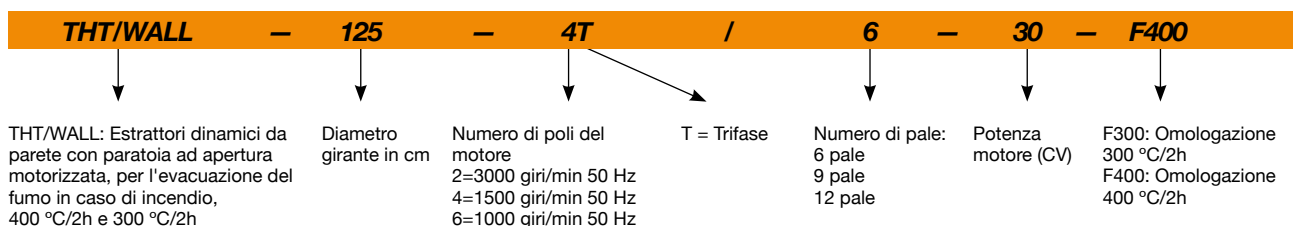

Caratteristiche tecniche

Modello	Velocità (giri/min)	Intensità massima consentita (A)			Potenza installata (kW)	Angolo di inclinazione delle pale (°)	Portata massima (m³/h)	Livello di pressione sonora ¹ dB (A)		Peso circa (Kg)
		230V	400V	690V				Aspirazione	Scarico	
THT/WALL-40-2T-1 IE3	2850	2,76	1,59		0,75	16	6100	62	62	62
THT/WALL-40-2T-1.5 IE3	2880	3,93	2,26		1,10	20	7040	61	61	63
THT/WALL-45-2T-2 IE3	2880	4,91	2,84		1,50	16	9400	61	61	67
THT/WALL-45-2T-3 IE3	2840	7,14	4,13		2,20	22	11325	61	61	68
THT/WALL-50-2T-4 IE3	2880	9,61	5,52		3,00	16	13860	66	66	84
THT/WALL-50-2T-5.5 IE3	2870		7,20	4,17	4,00	20	15900	66	66	100
THT/WALL-56-2T-5.5 IE3	2870		7,20	4,17	4,00	16	18820	68	68	105
THT/WALL-56-2T-7.5 IE3	2910		10,10	5,80	5,50	22	22510	68	68	107
THT/WALL-56-4T-2 IE3	1440	5,89	3,38		1,50	36	15020	54	54	84
THT/WALL-63-4T-3 IE3	1425	7,86	4,52		2,20	32	22170	58	58	131
THT/WALL-63-4T-4 IE3	1430	11,01	6,33		3,00	38	24240	59	59	132
THT/WALL-63-6T-1 IE3	940	3,36	1,93		0,75	38	15890	48	48	121
THT/WALL-71-4T-3 IE3	1425	7,86	4,52		2,20	22	25100	60	60	124
THT/WALL-71-4T-4 IE3	1430	11,01	6,33		3,00	28	27480	60	60	133
THT/WALL-71-4T-5.5 IE3	1440		7,95	4,61	4,00	38	32250	61	61	143
THT/WALL-71-6T-1.5 IE3	945	4,73	2,72		1,10	34	19930	51	51	123
THT/WALL-80-4T-3 IE3	1425	7,86	4,52		2,20	12	25460	65	65	138
THT/WALL-80-4T-4 IE3	1430	11,01	6,33		3,00	16	30270	64	64	147
THT/WALL-80-4T-5.5 IE3	1440		7,95	4,61	4,00	18	32770	63	63	153
THT/WALL-80-4T-7.5 IE3	1460		10,40	6,04	5,50	26	39640	63	63	154
THT/WALL-80-6T-1.5 IE3	945	4,73	2,72		1,10	18	21470	53	53	137
THT/WALL-80-6T-2 IE3	945	6,25	3,62		1,50	26	25970	54	54	146
THT/WALL-90-4T-7.5 IE3	1460		10,40	6,04	5,50	18	46140	67	67	222
THT/WALL-90-4T-10 IE3	1460		14,20	8,17	7,50	22	50140	66	66	233
THT/WALL-90-4T-15 IE3	1460		20,70	11,99	11,00	30	59390	68	68	242
THT/WALL-90-6T-3 IE3	950	9,78	5,62		2,20	24	34000	56	56	195
THT/WALL-90-6T-4 IE3	970	12,80	6,36		3,00	30	38910	59	59	221
THT/WALL-100-4T-10 IE3	1460		14,20	8,17	7,50	16	57420	69	69	239
THT/WALL-100-4T-15 IE3	1460		20,70	11,99	11,00	22	66300	69	69	292
THT/WALL-100-4T-20 IE3	1460		27,80	16,03	15,00	28	76160	70	70	307
THT/WALL-100-6T-5.5 IE3	970	8,37	4,82		4,00	26	47780	60	60	239
THT/WALL-100-6T-7.5 IE3	970	12,30	7,07		5,50	32	53520	62	62	276
THT/WALL-125-4T/6-20 IE3	1460	27,80	16,03	15,00	10	10	78600	77	77	462
THT/WALL-125-4T/6-25 IE3	1465	35,40	20,39	18,50	14	14	92550	76	76	530
THT/WALL-125-4T/6-30 IE3	1470	42,20	24,44	22,00	16	16	98830	75	75	544
THT/WALL-125-4T/6-40 IE3	1475	53,30	31,02	30,00	22	22	117450	75	75	625
THT/WALL-125-4T/6-50 IE3	1480	66,40	38,26	37,00	26	26	131050	75	75	673
THT/WALL-125-4T/9-25 IE3	1465	35,40	20,39	18,50	10	10	79650	77	77	539
THT/WALL-125-4T/9-30 IE3	1470	42,20	24,44	22,00	12	12	88290	76	76	553
THT/WALL-125-4T/9-40 IE3	1475	53,30	31,02	30,00	16	16	104040	75	75	634
THT/WALL-125-4T/9-50 IE3	1480	66,40	38,26	37,00	20	20	118400	75	75	682
THT/WALL-125-4T/12-30 IE3	1475	42,20	24,44	22,00	10	10	62900	78	78	569
THT/WALL-125-4T/12-40 IE3	1470	53,30	31,02	30,00	14	14	79180	77	77	650
THT/WALL-125-4T/12-50 IE3	1480	66,40	38,26	37,00	18	18	95715	76	76	693
THT/WALL-125-6T/6-5.5 IE3	970	8,37	4,82	4,00	10	10	51500	67	67	395
THT/WALL-125-6T/6-7.5 IE3	970	12,30	7,07	5,50	14	14	60640	65	65	402
THT/WALL-125-6T/6-10 IE3	960	15,20	8,83	7,50	20	20	72650	64	64	427
THT/WALL-125-6T/6-15 IE3	955	22,50	13,07	11,00	26	26	85850	64	64	457
THT/WALL-125-6T/6-20 IE3	950	29,00	16,78	15,00	30	30	92850	66	66	530
THT/WALL-125-6T/9-10 IE3	960	15,20	8,83	7,50	14	14	63490	67	67	436
THT/WALL-125-6T/9-15 IE3	955	22,50	13,07	11,00	20	20	77550	65	65	466
THT/WALL-125-6T/9-20 IE3	950	29,00	16,78	15,00	26	26	92950	65	65	539
THT/WALL-125-6T/9-25 IE3	975	36,10	20,77	18,50	32	32	96500	67	67	569
THT/WALL-125-6T/12-25 IE3	975	36,10	20,77	18,50	28	28	91680	67	67	579
THT/WALL-125-6T/12-30 IE3	975	42,30	24,35	22,00	32	32	102050	68	68	621
THT/WALL-125-6T/12-40 IE3	980	55,80	32,13	30,00	38	38	115950	72	72	739

¹ I valori dei livelli di rumore sono pressioni in dB(A), misurate in campo libero a una distanza di 10 metri.

Caratteristiche tecniche delle bocchette dinamiche in conformità con la norma EN 12101-3

Modello	Omologazione	Classe isolamento di motore	Durata	Temperatura ambiente minima	Carico di vento (Pa)
	(°C)	Classe H		(°C)	
THT/WALL	F300 e F400	Classe H	RE 11000	-25	WL 200



Erp. (Energy Related Products)

Informazioni sulla direttiva 2009/125/CE scaricabili dal sito web di SODECA o da QuickFan Selector.

Caratteristiche acustiche

Spettro di potenza sonora Lw(A) in dB(A) per banda di frequenza in Hz

Valori presi in aspirazione con portata massima

	63	125	250	500	1000	2000	4000	8000
40-2-1	48	64	76	84	89	87	83	76
40-2-1.5	47	63	75	83	88	86	82	75
45-2-2	47	60	74	86	87	86	82	74
45-2-3	47	64	74	81	88	86	83	75
50-2-4	58	74	84	91	92	89	88	89
50-2-5.5	58	74	84	91	92	89	88	89
56-2-5.5	53	66	84	92	94	93	88	81
56-2-7.5	53	66	84	92	94	93	88	81
56-4-2	52	64	73	79	79	79	73	65
63-4-3	56	68	77	83	83	83	77	69
63-4-4	57	69	78	84	84	84	78	70
63-6-1	49	59	69	73	74	72	65	57
71-4-3	56	72	79	85	85	85	81	73
71-4-4	63	75	79	85	85	86	83	75
71-4-5.5	64	76	80	86	86	87	84	76
71-6-1.5	47	65	74	77	77	72	65	56
80-4-3	55	71	84	91	91	88	82	74
80-4-4	54	70	83	90	90	87	81	73
80-4-5.5	53	69	82	89	89	86	80	72
80-4-7.5	53	69	82	89	89	86	80	72
80-6-1.5	53	68	75	78	79	76	70	62
80-6-2	59	69	75	79	80	78	73	65
90-4-7.5	59	75	86	92	93	91	86	78
90-4-10	58	74	85	91	92	90	85	77
90-4-15	60	76	87	93	94	92	87	79
90-6-3	52	67	78	82	82	78	71	63
90-6-4	60	70	80	85	85	82	76	68
100-4-10	64	80	87	94	95	93	89	81
100-4-15	71	83	87	93	94	94	91	83
100-4-20	72	84	88	94	95	95	92	84
100-6-5.5	57	72	82	85	86	83	75	67
100-6-7.5	59	74	84	87	88	85	77	69
125-4/6-20	69	85	96	103	104	102	95	87
125-4/6-25	68	84	95	102	103	101	94	86
125-4/6-30	67	83	94	101	102	100	93	85
125-4/6-40	67	83	94	101	102	100	93	85
125-4/6-50	67	83	94	101	102	100	93	85
125-4/9-25	67	81	94	102	104	101	96	88
125-4/9-30	66	80	93	101	103	100	95	87
125-4/9-40	65	79	92	100	102	99	94	86
125-4/9-50	65	79	92	100	102	99	94	86
125-6/6-5.5	64	79	89	92	93	90	85	77
125-6/6-7.5	62	77	87	90	91	88	83	75
125-6/6-10	61	76	86	89	90	87	82	74
125-6/6-15	61	76	86	89	90	87	82	74
125-6/6-20	63	78	88	91	92	89	84	76
125-6/9-10	61	76	87	93	94	88	84	77
125-6/9-15	59	74	85	91	92	86	82	75
125-6/9-20	59	74	85	91	92	86	82	75
125-6/9-25	61	76	87	93	94	88	84	77
125-4/12-30	68	82	95	103	105	102	97	89
125-4/12-40	67	81	94	102	104	101	96	88
125-4/12-50	66	80	93	101	103	100	95	87
125-6/12-25	61	76	87	93	94	88	84	77
125-6/12-30	62	77	88	94	95	89	85	78
125-6/12-40	66	81	92	98	99	93	89	82

Valori presi allo scarico con portata massima

	63	125	250	500	1000	2000	4000	8000
40-2-1	48	64	76	84	89	87	83	76
40-2-1.5	47	63	75	83	88	86	82	75
45-2-2	47	60	74	86	87	86	82	74
45-2-3	47	64	74	81	88	86	83	75
50-2-4	58	74	84	91	92	89	88	89
50-2-5.5	58	74	84	91	92	89	88	89
56-2-5.5	53	66	84	92	94	93	88	81
56-2-7.5	53	66	84	92	94	93	88	81
56-4-2	52	64	73	79	79	79	73	65
63-4-3	56	68	77	83	83	83	77	69
63-4-4	57	69	78	84	84	84	78	70
63-6-1	49	59	69	73	74	72	65	57
71-4-3	56	72	79	85	85	85	81	73
71-4-4	63	75	79	85	85	86	83	75
71-4-5.5	64	76	80	86	86	87	84	76
71-6-1.5	47	65	74	77	77	72	65	56
80-4-3	55	71	84	91	91	88	82	74
80-4-4	54	70	83	90	90	87	81	73
80-4-5.5	53	69	82	89	89	86	80	72
80-4-7.5	53	69	82	89	89	86	80	72
80-6-1.5	53	68	75	78	79	76	70	62
80-6-2	59	69	75	79	80	78	73	65
90-4-7.5	59	75	86	92	93	91	86	78
90-4-10	58	74	85	91	92	90	85	77
90-4-15	60	76	87	93	94	92	87	79
90-6-3	52	67	78	82	82	78	71	63
90-6-4	60	70	80	85	85	82	76	68
100-4-10	64	80	87	94	95	93	89	81
100-4-15	71	83	87	93	94	94	91	83
100-4-20	72	84	88	94	95	95	92	84
100-6-5.5	57	72	82	85	86	83	75	67
100-6-7.5	59	74	84	87	88	85	77	69
125-4/6-20	69	85	96	103	104	102	95	87
125-4/6-25	68	84	95	102	103	101	94	86
125-4/6-30	67	83	94	101	102	100	93	85
125-4/6-40	67	83	94	101	102	100	93	85
125-4/6-50	67	83	94	101	102	100	93	85
125-4/9-25	67	81	94	102	104	101	96	88
125-4/9-30	66	80	93	101	103	100	95	87
125-4/9-40	65	79	92	100	102	99	94	86
125-4/9-50	65	79	92	100	102	99	94	86
125-6/6-5.5	64	79	89	92	93	90	85	77
125-6/6-7.5	62	77	87	90	91	88	83	75
125-6/6-10	61	76	86	89	90	87	82	74
125-6/6-15	61	76	86	89	90	87	82	74
125-6/6-20	63	78	88	91	92	89	84	76
125-6/9-10	61	76	87	93	94	88	84	77
125-6/9-15	59	74	85	91	92	86	82	75
125-6/9-20	59	74	85	91	92	86	82	75
125-6/9-25	61	76	87	93	94	88	84	77
125-4/12-30	68	82	95	103	105	102	97	89
125-4/12-40	67	81	94	102	104	101	96	88
125-4/12-50	66	80	93	101	103	100	95	87
125-6/12-25	61	76	87	93	94	88	84	77
125-6/12-30	62	77	88	94	95	89	85	78
125-6/12-40	66	81	92	98	99	93	89	82

Dimensioni in mm

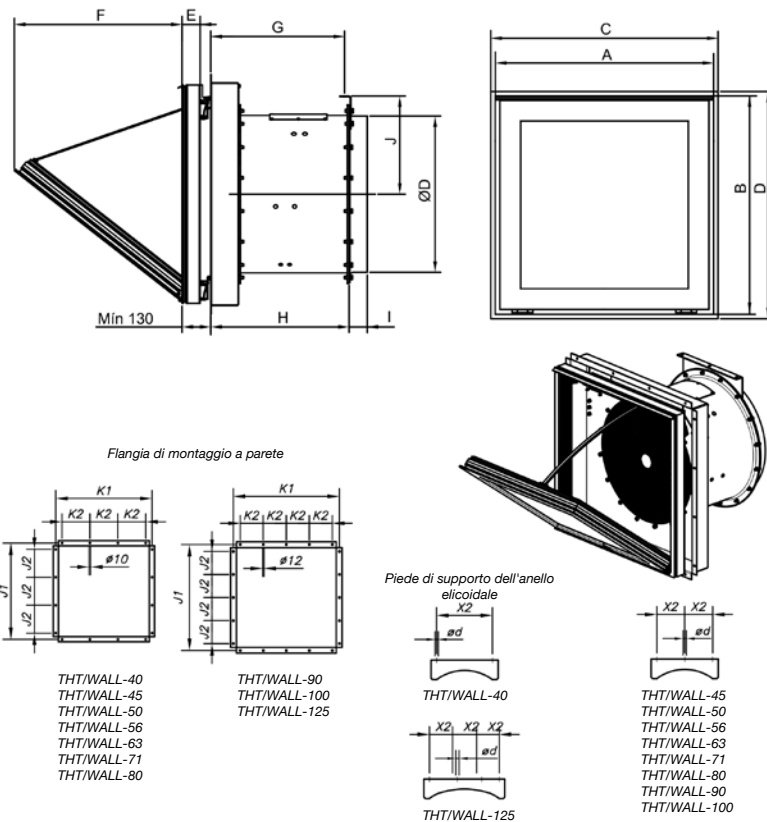

	A	B	C	D	ØD*	I	J	H	G	E	F	J1	J2	K1	K2	X2	ød
THT/WALL-40	640	590	650	600	400	80	255	530	510	82	430	700	200	700	200	200	10
THT/WALL-45	640	590	650	600	450	80	280	530	510	82	430	700	200	700	200	200	12
THT/WALL-50	690	690	700	700	500	80	305	530	510	82	560	790	220	790	220	200	12
THT/WALL-56	690	690	700	700	560	80	340	530	510	82	560	790	220	790	220	215	13
THT/WALL-56-2T-7.5	690	690	700	700	560	80	340	630	610	82	560	790	220	790	220	215	13
THT/WALL-63	990	990	1000	1000	630	80	385	630	605	82	760	1050	300	1050	300	215	13
THT/WALL-63-6T-1	990	990	1000	1000	630	80	385	530	505	82	760	1050	300	1050	300	215	13
THT/WALL-71	990	990	1000	1000	710	80	445	630	605	82	760	1050	300	1050	300	225	13
THT/WALL-80	990	990	1000	1000	800	100	490	630	605	82	760	1050	300	1050	300	280	13
THT/WALL-90	1190	1190	1200	1200	900	100	550	730	705	82	790	1250	250	1250	250	280	18
THT/WALL-90-4T-15	1190	1190	1200	1200	900	100	550	830	805	82	790	1250	250	1250	250	280	18
THT/WALL-100	1190	1190	1200	1200	1000	100	600	730	705	82	790	1250	250	1250	250	280	18
THT/WALL-100-4T-15	1190	1190	1200	1200	1000	100	600	830	805	82	790	1250	250	1250	250	280	18
THT/WALL-100-4T-20	1190	1190	1200	1200	1000	100	600	830	805	82	790	1250	250	1250	250	280	18
THT/WALL-125	1490	1490	1500	1500	1250	100	725	1050	1025	82	1240	1600	300	1600	300	300	18
THT/WALL-125-4T/6-20	1490	1490	1500	1500	1250	100	725	850	825	82	1240	1600	300	1600	300	300	18
THT/WALL-125-6T/6-5.5	1490	1490	1500	1500	1250	100	725	850	825	82	1240	1600	300	1600	300	300	18
THT/WALL-125-6T/6-7.5	1490	1490	1500	1500	1250	100	725	850	825	82	1240	1600	300	1600	300	300	18
THT/WALL-125-6T/6-10	1490	1490	1500	1500	1250	100	725	850	825	82	1240	1600	300	1600	300	300	18
THT/WALL-125-6T/6-15	1490	1490	1500	1500	1250	100	725	850	825	82	1240	1600	300	1600	300	300	18
THT/WALL-125-6T/9-10	1490	1490	1500	1500	1250	100	725	850	825	82	1240	1600	300	1600	300	300	18
THT/WALL-125-6T/9-15	1490	1490	1500	1500	1250	100	725	850	825	82	1240	1600	300	1600	300	300	18
THT/WALL-125-4T/6-50	1490	1490	1500	1500	1250	100	725	1150	1125	82	1240	1600	300	1600	300	300	18
THT/WALL-125-4T/9-50	1490	1490	1500	1500	1250	100	725	1150	1125	82	1240	1600	300	1600	300	300	18
THT/WALL-125-4T/12-50	1490	1490	1500	1500	1250	100	725	1150	1125	82	1240	1600	300	1600	300	300	18

* Diametro nominale raccomandato per le tubazioni
(C x D) Dimensione nominale dell'apertura nella parete.

Curve caratteristiche

Q= Portata in m³/h, m³/s e cfm

Pe= Pressione statica in mmH₂O, Pa e in wg

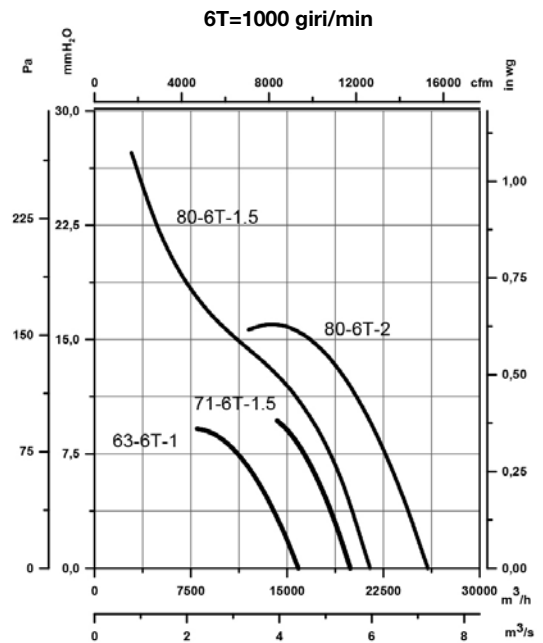
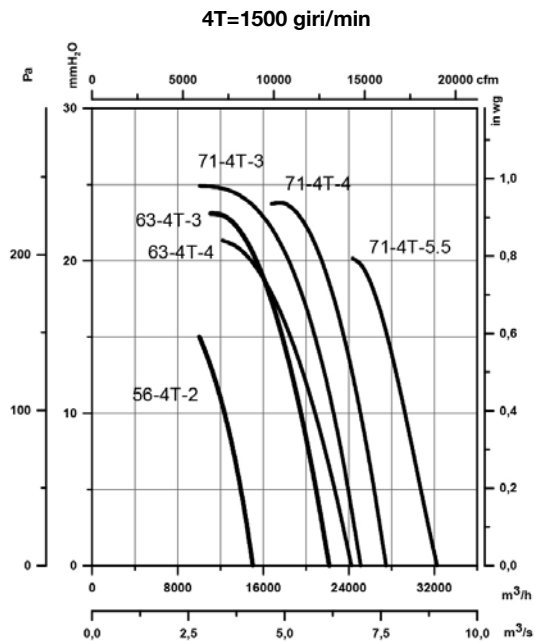
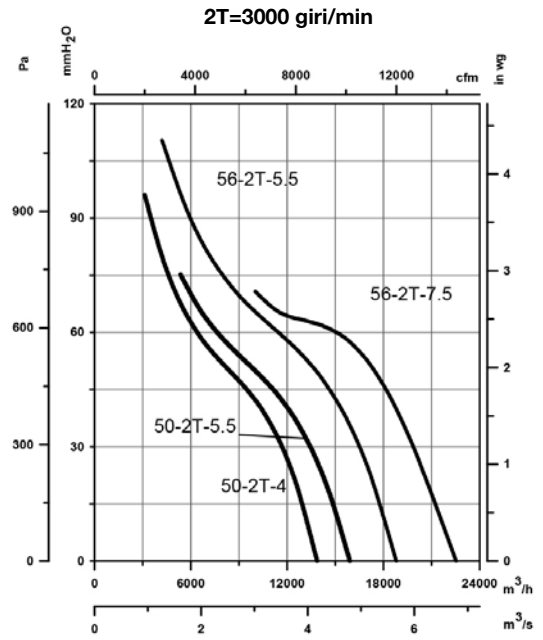
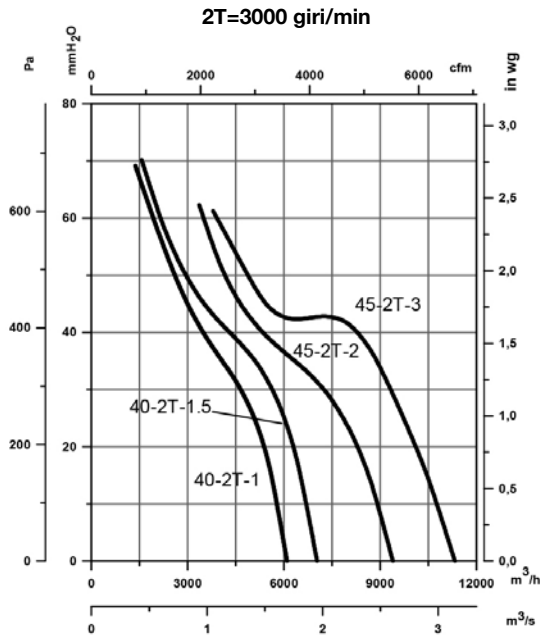

Curve caratteristiche

Q= Portata in m³/h, m³/s e cfm

Pe= Pressione statica in mmH₂O, Pa e in wg

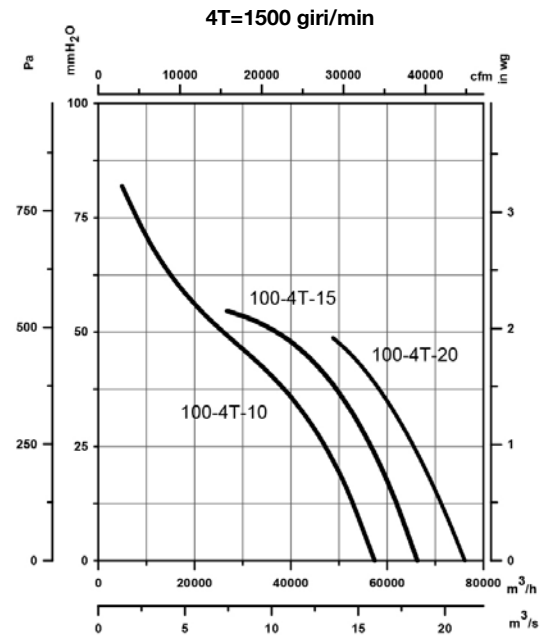
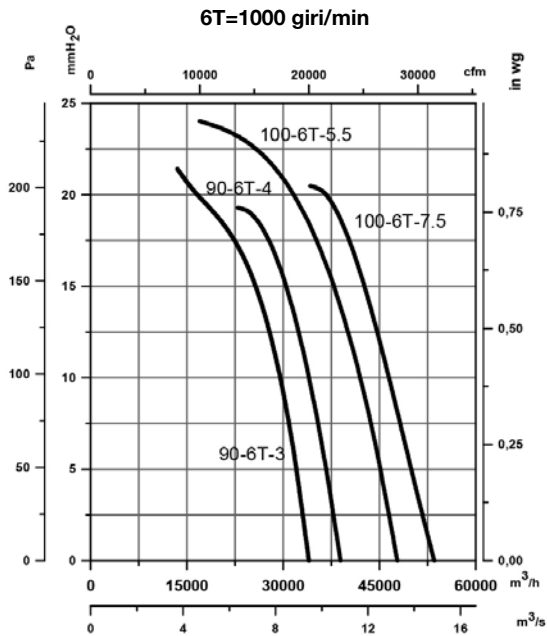
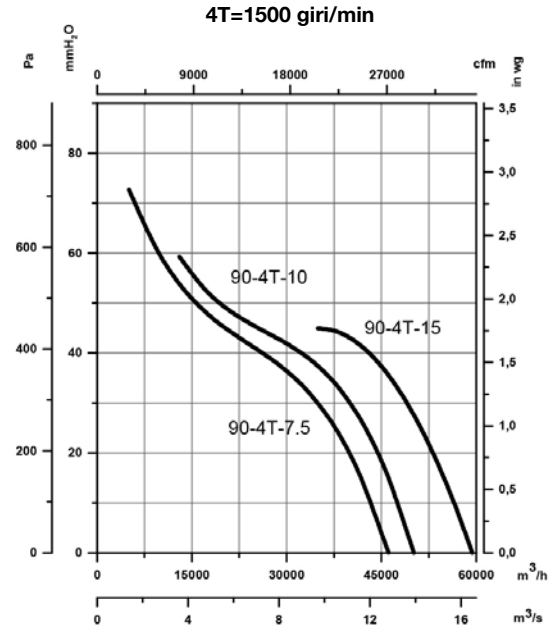
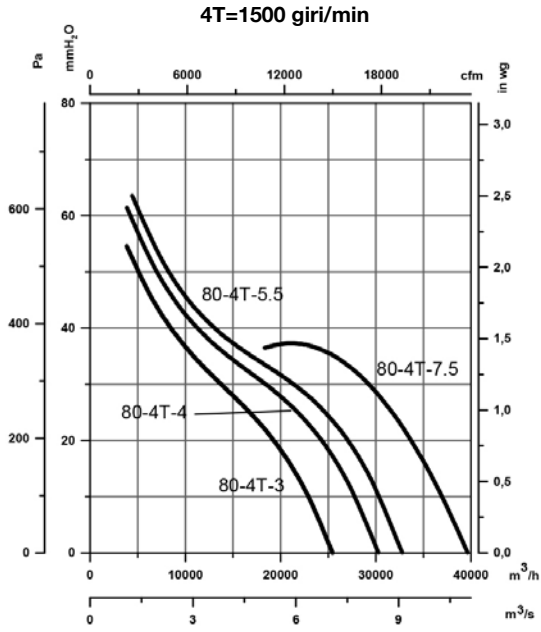

Curve caratteristiche

Q= Portata in m³/h, m³/s e cfm

Pe= Pressione statica in mmH₂O, Pa e in wg

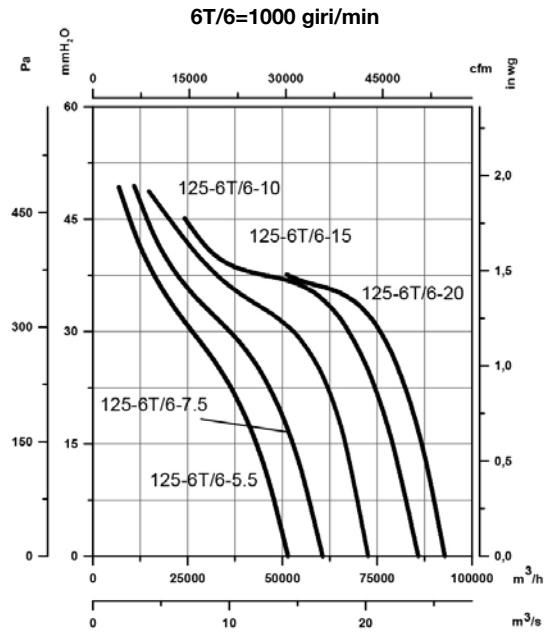
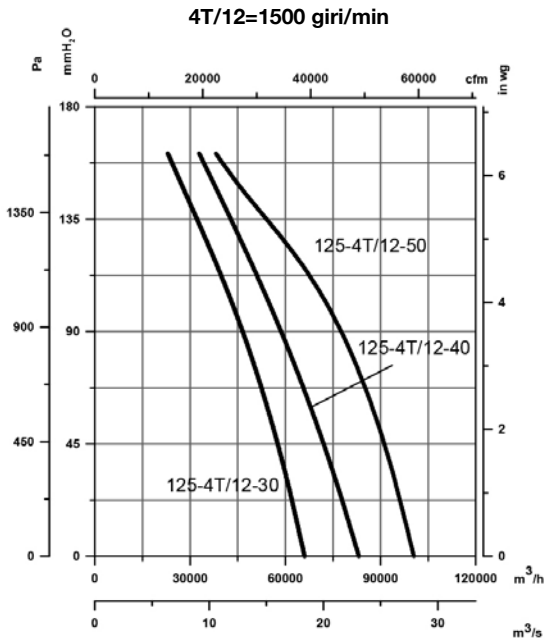
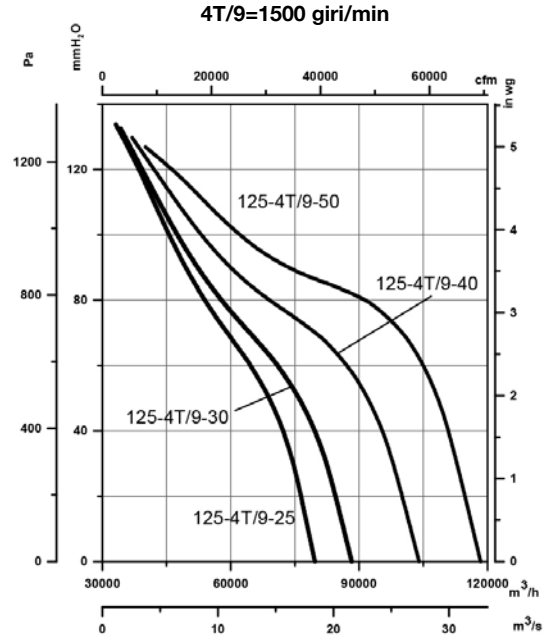
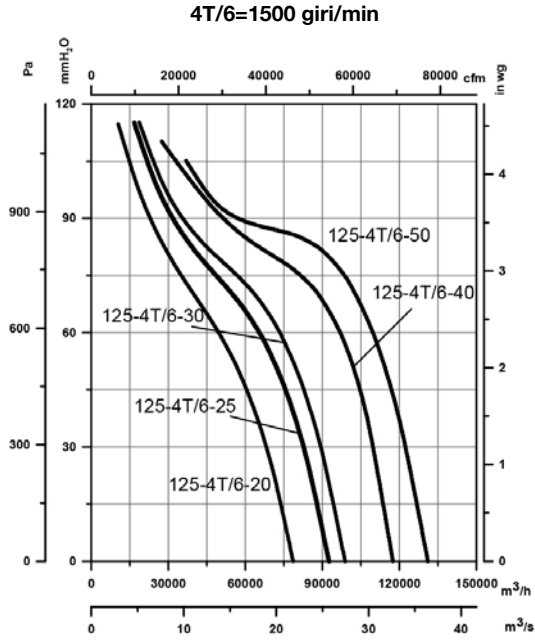

Curve caratteristiche

Q= Portata in m³/h, m³/s e cfm

Pe= Pressione statica in mmH₂O, Pa e inwg

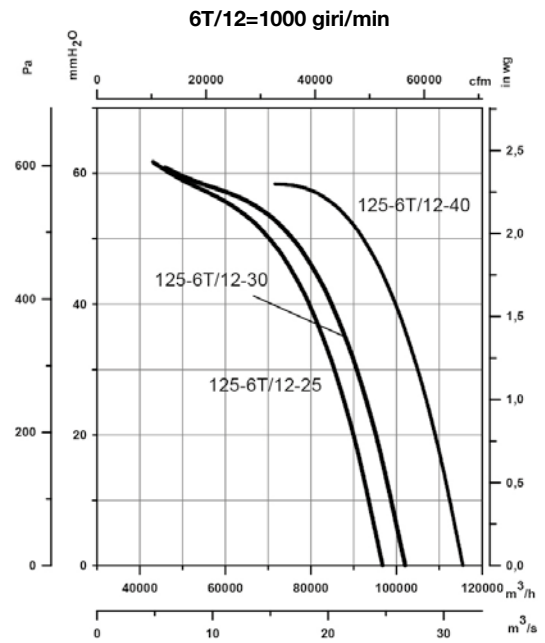
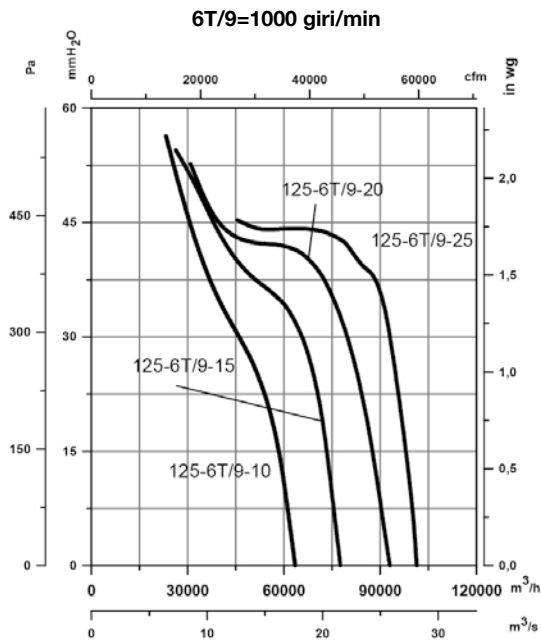

Accessori



INT



IAT



CABLE BOX



C2V



VSD3/A-RFT
- VSD1/A-RFM



CENTRAL CO



AET



P-400



RT



R/THT



BAC



PS



ACE ACE/400



S