

THT/HATCH



400 °C/2h and 300 °C/2h rated dynamic discharge system with motorised opening function, equipped with roof mounted extractor, for smoke exhaust in the event of fire



THT/HATCH-40...100



THT/HATCH-125

Dynamic discharge systems with roof-mounted extract fans and motorised opening function. Specially designed for the fast, effective exhaust of harmful smoke and gases in the event of fire. Suitable for installation in industrial or commercial buildings. Approved in accordance with standard EN 12101-3, with F400 and F300 certificate. The rapid smoke extract permits the efficient intervention of fire fighters, fast evacuation of people and prevents new sources of fire and greater structural damage to the building. Can also be used for ambient ventilation in the buildings in which it is installed.

Fan:

- An extremely robust structure that is able to withstand severe weather changes.
- Equipment structure made of anti-corrosive galvanised sheet steel.
- Designed to ensure watertightness.
- 100 mm thick thermal insulation for the hatch and 60 mm for the sides.
- Adapter socket (or skirting) for correct and easy installation on the roof.
- Maintenance switches for actuator and fan disconnection with auxiliary contacts.
- Roof mounted extract fans with F400 certificate No. 0370-CPR-1827 and F300 certificate No. 0370-CPR-3406.
- Tubular casing in sheet steel with polyester resin anti-corrosive treatment.
- Adjustable cast aluminum impeller.
- Shielded power cable with EMC protection.

Opening system:

- Motorised opening arm, with encapsulated IP65 mechanism.
- Supply voltage at 230 V AC 50/60 Hz.
- System reinforced and guaranteed with more than 11,000 cycles.
- Snow load SL 1000.
- Automatic opening by external signal from the control system (fire panel, smoke detector ...). Control systems not included in the equipment.
- Limit switches in both positions (open and closed).

Motor:

- Class H motors for S1 continuous operation and S2 emergency use. With ball bearings and IP55 protection.
- IE3 efficiency motors.
- Three-phase 230/400 V 50 Hz (up to 3 kW) and 400/690 V 50 Hz (powers greater than 3 kW).
- Maximum temperature of air to be carried: S1 -25 °C +40 °C continuous service, also suitable for warm climates with temperatures up to 50 °C. S2 operation, 300 °C/2h, 400 °C/2h.

Finish:

- Galvanised steel sheet.

On request:

- Polyester resin anti-corrosive paint finish.
- Motorised opening arms with supply voltage of 24 V DC.
- Protection grille against contact according to UNE-EN ISO 12499 for inlet and/or outlet.

Order code

From size 40 to size 100

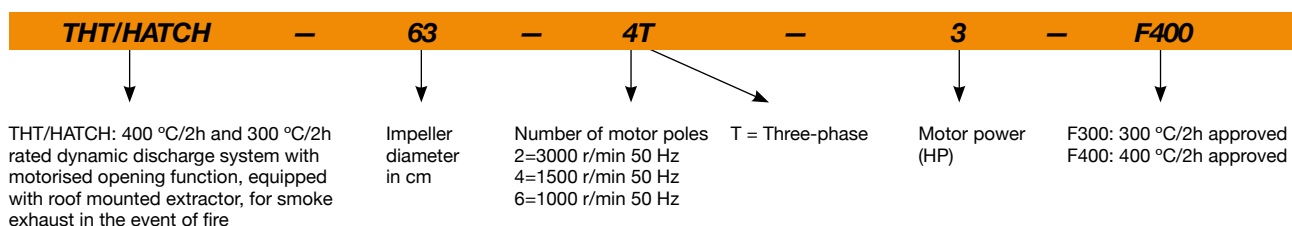

Order code

Size 125

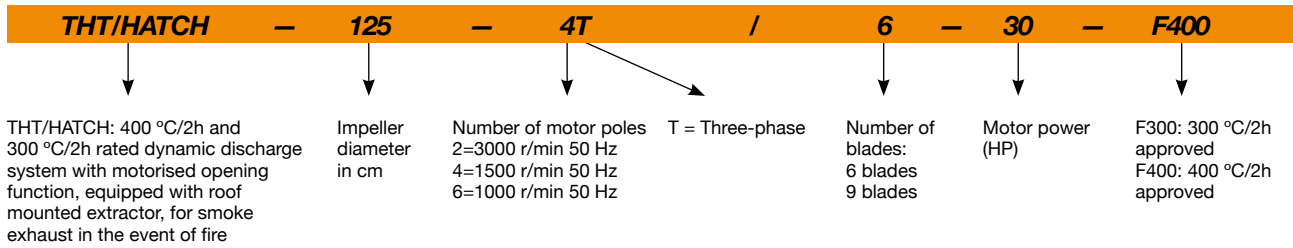

Technical characteristics

Model	Speed (r/min)	Maximum admissible current (A)			Installed power (kW)	Blade tilt angle (°)	Maximum flow rate (m³/h)	Sound pressure level ¹ dB (A)		Approx. weight (Kg)
		230V	400V	690V				Inlet	Exhaust	
THT/HATCH-40-2T-1 IE3	2850	2.76	1.59		0.75	16	6100	62	62	184
THT/HATCH-40-2T-1.5 IE3	2880	3.93	2.26		1.10	20	7040	61	61	188
THT/HATCH-45-2T-2 IE3	2880	4.91	2.84		1.50	16	9400	61	61	193
THT/HATCH-45-2T-3 IE3	2840	7.14	4.13		2.20	22	11325	61	61	194
THT/HATCH-50-2T-4 IE3	2880	9.61	5.52		3.00	16	13860	66	66	206
THT/HATCH-56-2T-5.5 IE3	2870		7.20	4.17	4.00	16	18820	68	68	226
THT/HATCH-56-2T-7.5 IE3	2910		10.10	5.80	5.50	22	22510	68	68	237
THT/HATCH-63-4T-3 IE3	1425	7.86	4.52		2.20	32	22170	58	58	262
THT/HATCH-63-4T-4 IE3	1430	11.01	6.33		3.00	38	24240	59	59	271
THT/HATCH-63-6T-1 IE3	940	3.36	1.93		0.75	38	15890	48	48	252
THT/HATCH-80-4T-3 IE3	1425	7.86	4.52		2.20	12	25460	65	65	280
THT/HATCH-80-4T-4 IE3	1430	11.01	6.33		3.00	16	30270	64	64	289
THT/HATCH-80-4T-5.5 IE3	1440		7.95	4.61	4.00	18	32770	63	63	295
THT/HATCH-80-4T-7.5 IE3	1460		10.40	6.04	5.50	26	39640	63	63	311
THT/HATCH-80-6T-1.5 IE3	945	4.73	2.72		1.10	18	21470	53	53	279
THT/HATCH-80-6T-2 IE3	945	6.25	3.62		1.50	26	25970	54	54	288
THT/HATCH-90-4T-7.5 IE3	1460		10.40	6.04	5.50	18	46140	67	67	392
THT/HATCH-90-4T-10 IE3	1460		14.20	8.17	7.50	22	50140	66	66	403
THT/HATCH-90-4T-15 IE3	1460		20.70	11.99	11.00	30	59390	68	68	456
THT/HATCH-90-6T-3 IE3	950	9.78	5.62		2.20	24	34000	56	56	365
THT/HATCH-90-6T-4 IE3	970	12.80	6.36		3.00	30	38910	59	59	391
THT/HATCH-100-4T-10 IE3	1460		14.20	8.17	7.50	16	57420	69	69	413
THT/HATCH-100-4T-15 IE3	1460		20.70	11.99	11.00	22	66300	69	69	466
THT/HATCH-100-4T-20 IE3	1460		27.80	16.03	15.00	28	76160	70	70	481
THT/HATCH-100-4T/9-25 IE3	1475		35.40	20.39	18.50	26	70620	70	70	535
THT/HATCH-100-4T/9-30 IE3	1475		42.20	24.44	22.00	30	74840	72	72	552
THT/HATCH-100-6T-5.5 IE3	970		8.37	4.82	4.00	26	47780	60	60	413
THT/HATCH-100-6T-7.5 IE3	970		12.30	7.07	5.50	32	53520	62	62	420
THT/HATCH-125-4T/6-25 IE3	1465		35.40	20.39	18.50	14	92550	76	76	746
THT/HATCH-125-4T/6-30 IE3	1470		42.20	24.44	22.00	16	98830	75	75	760
THT/HATCH-125-4T/6-40 IE3	1475		53.30	31.02	30.00	22	117450	75	75	841
THT/HATCH-125-4T/6-50 IE3	1480		66.40	38.26	37.00	26	131050	75	75	889
THT/HATCH-125-4T/9-25 IE3	1465		35.40	20.39	18.50	10	79650	77	77	755
THT/HATCH-125-4T/9-30 IE3	1470		42.20	24.44	22.00	12	88290	76	76	769
THT/HATCH-125-4T/9-40 IE3	1475		53.30	31.02	30.00	16	104040	75	75	850
THT/HATCH-125-4T/9-50 IE3	1480		66.40	38.26	37.00	20	118400	75	75	898
THT/HATCH-125-6T/6-5.5 IE3	970		8.37	4.82	4.00	10	51500	67	67	611
THT/HATCH-125-6T/6-7.5 IE3	970		12.30	7.07	5.50	14	60640	65	65	618
THT/HATCH-125-6T/6-10 IE3	960		15.20	8.83	7.50	20	72650	64	64	643
THT/HATCH-125-6T/6-15 IE3	955		22.50	13.07	11.00	26	85850	64	64	673
THT/HATCH-125-6T/6-20 IE3	950		29.00	16.78	15.00	30	92850	66	66	746
THT/HATCH-125-6T/9-10 IE3	960		15.20	8.83	7.50	14	63490	67	67	652
THT/HATCH-125-6T/9-15 IE3	955		22.50	13.07	11.00	20	77550	65	65	682
THT/HATCH-125-6T/9-20 IE3	950		29.00	16.78	15.00	26	92950	65	65	755

¹ The noise level values are pressures in dB(A) measured at a distance of 10 metres in a free field.

Technical characteristics of the dynamic exhaust system based on standards EN 12101-3 and EN 12101-2

Model	Approval (°C)	Motor insulation class	Durability	Temperature room temperature (°C)	Wind load (Pa)	Snow load (Pa)
THT/HATCH	F300 and F400	Class H	RE 11000	-25	WL 200	SL 1000



Erp. (Energy Related Products)

Information on Directive 2009/125/EC can be downloaded from the SODECA website or the QuickFan selector programme.

Acoustic characteristics

The values given are obtained under laboratory conditions according to ISO 3744.
Sound power spectrum Lw(A) in dB(A) per Hz frequency band

Values measured at inlet with maximum flow rate

	63	125	250	500	1000	2000	4000	8000
40-2-1	48	64	76	84	89	87	83	76
40-2-1.5	47	63	75	83	88	86	82	75
45-2-2	47	60	74	86	87	86	82	74
45-2-3	47	64	74	81	88	86	83	75
50-2-4	58	74	84	91	92	89	88	89
56-2-5.5	53	66	84	92	94	93	88	81
56-2-7.5	53	66	84	92	94	93	88	81
63-4-3	56	68	77	83	83	83	77	69
63-4-4	57	69	78	84	84	84	78	70
63-6-1	49	59	69	73	74	72	65	57
80-4-3	55	71	84	91	91	88	82	74
80-4-4	54	70	83	90	90	87	81	73
80-4-5.5	53	69	82	89	89	86	80	72
80-4-7.5	53	69	82	89	89	86	80	72
80-6-1.5	53	68	75	78	79	76	70	62
80-6-2	59	69	75	79	80	78	73	65
90-4-7.5	59	75	86	92	93	91	86	78
90-4-10	58	74	85	91	92	90	85	77
90-4-15	60	76	87	93	94	92	87	79
90-6-3	52	67	78	82	82	78	71	63
90-6-4	60	70	80	85	85	82	76	68
100-4-10	64	80	87	94	95	93	89	81
100-4-15	71	83	87	93	94	94	91	83
100-4-20	72	84	88	94	95	95	92	84
100-4/9-25	72	84	88	94	95	95	92	84
100-4/9-30	74	86	90	96	97	97	94	86
100-6-5.5	57	72	82	85	86	83	75	67
100-6-7.5	59	74	84	87	88	85	77	69
125-4/6-25	68	84	95	102	103	101	94	86
125-4/6-30	67	83	94	101	102	100	93	85
125-4/6-40	67	83	94	101	102	100	93	85
125-4/6-50	67	83	94	101	102	100	93	85
125-4/9-25	67	81	94	102	104	101	96	88
125-4/9-30	66	80	93	101	103	100	95	87
125-4/9-40	65	79	92	100	102	99	94	86
125-4/9-50	65	79	92	100	102	99	94	86
125-6/6-5.5	64	79	89	92	93	90	85	77
125-6/6-7.5	62	77	87	90	91	88	83	75
125-6/6-10	61	76	86	89	90	87	82	74
125-6/6-15	61	76	86	89	90	87	82	74
125-6/6-20	63	78	88	91	92	89	84	76
125-6/9-10	61	76	87	93	94	88	84	77
125-6/9-15	59	74	85	91	92	86	82	75
125-6/9-20	59	74	85	91	92	86	82	75

Values measured at exhaust with maximum flow rate

	63	125	250	500	1000	2000	4000	8000
40-2-1	48	64	76	84	89	87	83	76
40-2-1.5	47	63	75	83	88	86	82	75
45-2-2	47	60	74	86	87	86	82	74
45-2-3	47	64	74	81	88	86	83	75
50-2-4	58	74	84	91	92	89	88	89
56-2-5.5	53	66	84	92	94	93	88	81
56-2-7.5	53	66	84	92	94	93	88	81
63-4-3	56	68	77	83	83	83	77	69
63-4-4	57	69	78	84	84	84	78	70
63-6-1	49	59	69	73	74	72	65	57
80-4-3	55	71	84	91	91	88	82	74
80-4-4	54	70	83	90	90	87	81	73
80-4-5.5	53	69	82	89	89	86	80	72
80-4-7.5	53	69	82	89	89	86	80	72
80-6-1.5	53	68	75	78	79	76	70	62
80-6-2	59	69	75	79	80	78	73	65
90-4-7.5	59	75	86	92	93	91	86	78
90-4-10	58	74	85	91	92	90	85	77
90-4-15	60	76	87	93	94	92	87	79
90-6-3	52	67	78	82	82	78	71	63
90-6-4	60	70	80	85	85	82	76	68
100-4-10	64	80	87	94	95	93	89	81
100-4-15	71	83	87	93	94	94	91	83
100-4-20	72	84	88	94	95	95	92	84
100-4/9-25	72	84	88	94	95	95	92	84
100-4/9-30	74	86	90	96	97	97	94	86
100-6-5.5	57	72	82	85	86	83	75	67
100-6-7.5	59	74	84	87	88	85	77	69
125-4/6-25	68	84	95	102	103	101	94	86
125-4/6-30	67	83	94	101	102	100	93	85
125-4/6-40	67	83	94	101	102	100	93	85
125-4/6-50	67	83	94	101	102	100	93	85
125-4/9-25	67	81	94	102	104	101	96	88
125-4/9-30	66	80	93	101	103	100	95	87
125-4/9-40	65	79	92	100	102	99	94	86
125-4/9-50	65	79	92	100	102	99	94	86
125-6/6-5.5	64	79	89	92	93	90	85	77
125-6/6-7.5	62	77	87	90	91	88	83	75
125-6/6-10	61	76	86	89	90	87	82	74
125-6/6-15	61	76	86	89	90	87	82	74
125-6/6-20	63	78	88	91	92	89	84	76
125-6/9-10	61	76	87	93	94	88	84	77
125-6/9-15	59	74	85	91	92	86	82	75
125-6/9-20	59	74	85	91	92	86	82	75

Dimensions mm

THT/HATCH-40...100

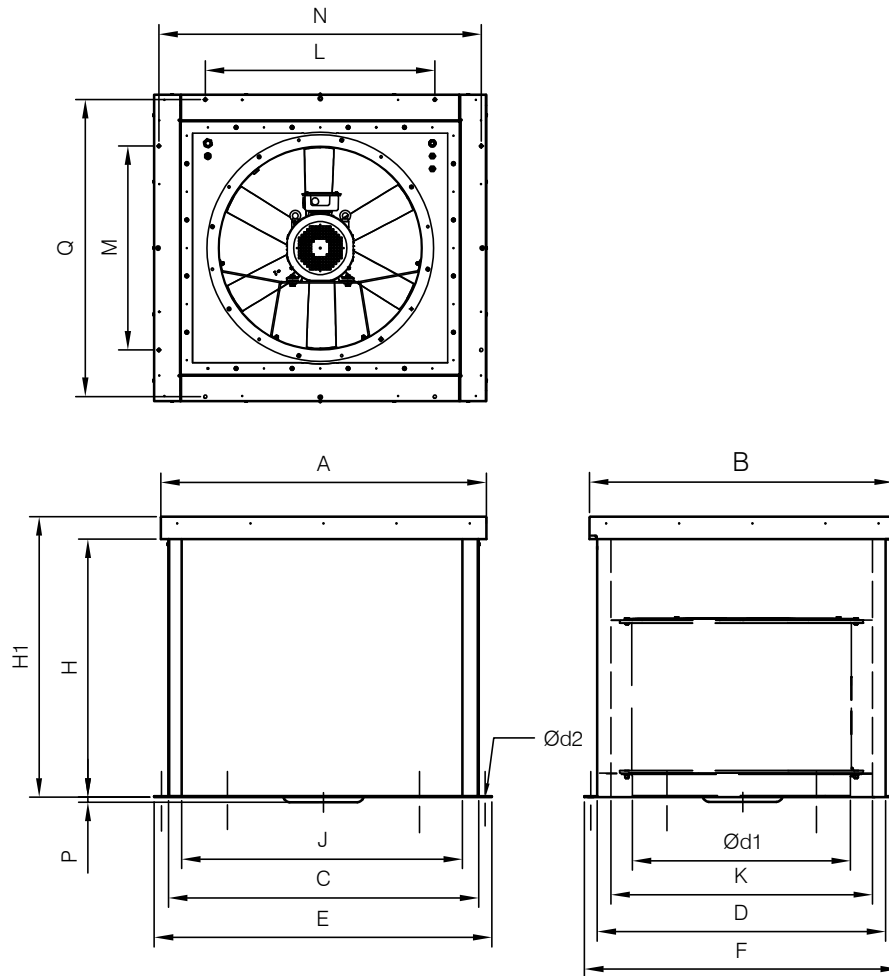

	A	B	C	D	$\varnothing d1$	$\varnothing d2$	E	F	H	H1	J	K	L	M	N	P	Q
THT/HATCH-40	1100	1000	1020	920	400	13	1100	1000	900	1000	900	800	700	600	1065	-	965
THT/HATCH-45	1100	1000	1020	920	450	13	1100	1000	900	1000	900	800	700	600	1065	-	965
THT/HATCH-50	1100	1000	1020	920	500	13	1100	1000	900	1000	900	800	700	600	1065	-	965
THT/HATCH-56	1100	1000	1020	920	560	13	1100	1000	900	1000	900	800	700	600	1065	-	965
THT/HATCH-63	1300	1200	1220	1120	630	13	1300	1200	900	1000	1100	1000	900	800	1265	-	1165
THT/HATCH-80	1300	1200	1220	1120	800	13	1300	1200	900	1000	1100	1000	900	800	1265	-	1165
THT/HATCH-90	1500	1400	1420	1320	900	13	1500	1400	900	1000	1300	1200	1100	1000	1465	-	1365
THT/HATCH-90-4T-15	1500	1400	1420	1320	900	13	1500	1400	900	1000	1300	1200	1100	1000	1465	38	1365
THT/HATCH-100	1500	1400	1420	1320	1000	13	1500	1400	900	1000	1300	1200	1100	1000	1465	-	1365
THT/HATCH-100-4T-15	1500	1400	1420	1320	1000	13	1500	1400	900	1000	1300	1200	1100	1000	1465	80	1365
THT/HATCH-100-4T-20	1500	1400	1420	1320	1000	13	1500	1400	900	1000	1300	1200	1100	1000	1465	80	1365
THT/HATCH-100-4T/9-25	1500	1400	1420	1320	1000	13	1500	1400	900	1000	1300	1200	1100	1000	1465	125	1365
THT/HATCH-100-4T/9-30	1500	1400	1420	1320	1000	13	1500	1400	900	1000	1300	1200	1100	1000	1465	125	1365

Dimensions mm

THT/HATCH-125

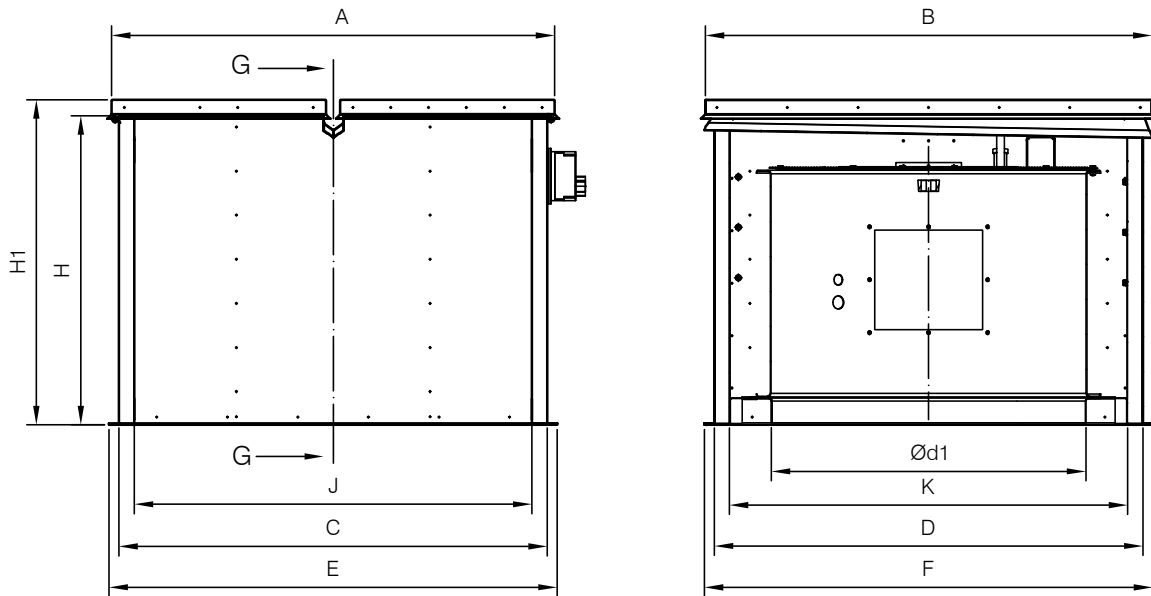

	A	B	C	D	ød1	E	F	H	H1	J	K
THT/HATCH-125	1750	1775	1700	1700	1245	1780	1780	1230	1330	1580	1580

Installation diagram

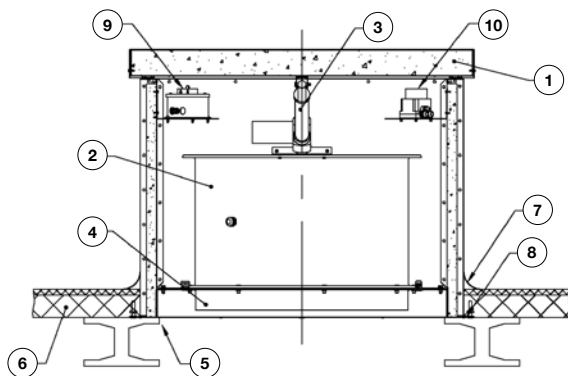

1. THT/HATCH box
2. THT fan
3. Motorised arm (230 V AC or 24 V DC)
4. Connection flange in inlet conduit
5. Roof opening
6. Roof
7. Protection against water entry
8. Direct assembly using the adjustable baseboard
9. Motor safety switch
10. Actuator safety switch

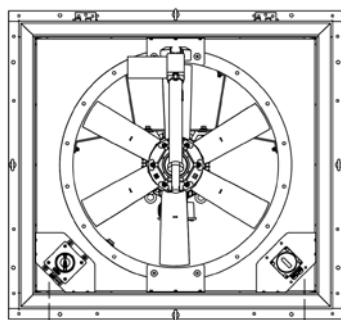

--- Pre-installed by the manufacturer

Note: For motors with powers greater than 5.5 kW it is advisable to use an electronic starter.

Motor power supply 3x400 V 50 Hz Actuator power supply 1x230 V 50/60 Hz or 24 V DC

Characteristic curves

Q= Flow rate in m³/h, m³/s and cfm

Pe= Static pressure in mm H₂O, Pa and inwg

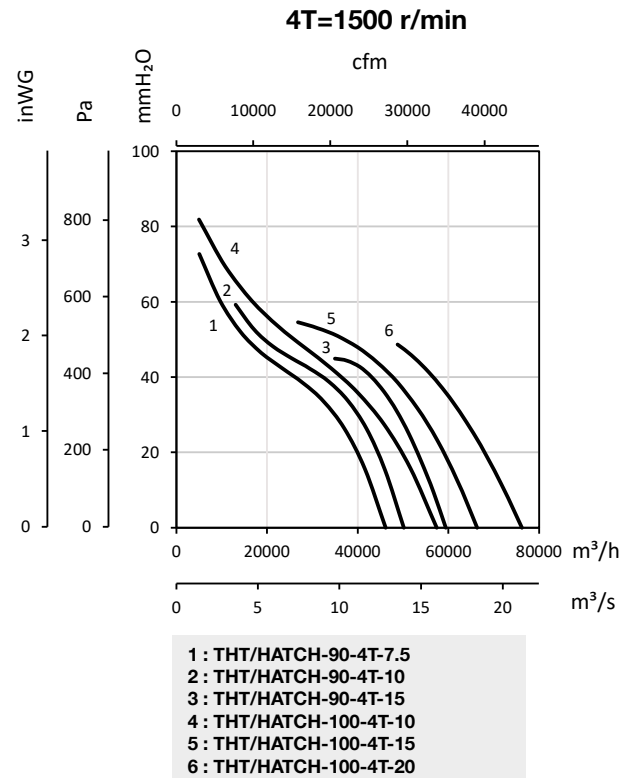
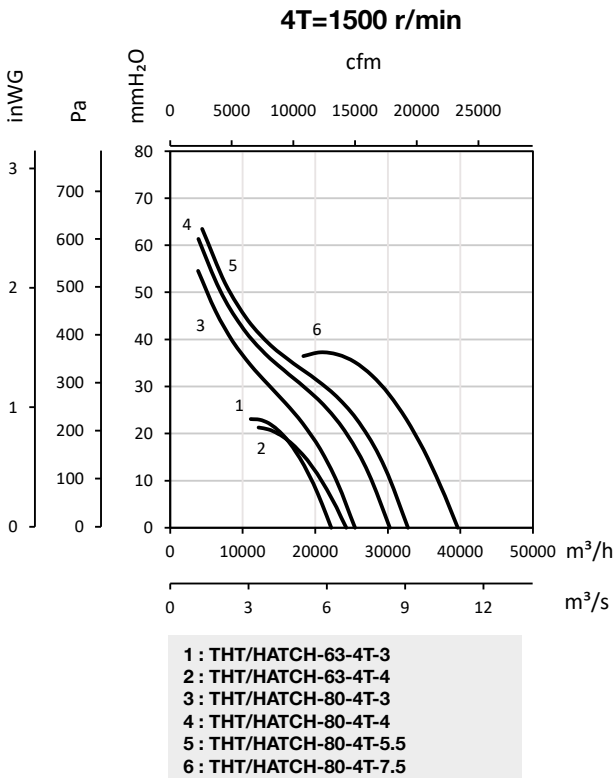
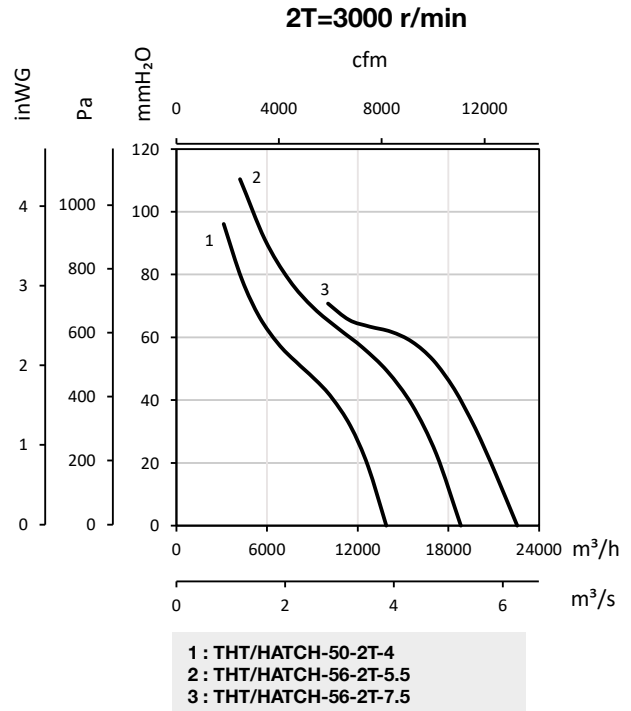
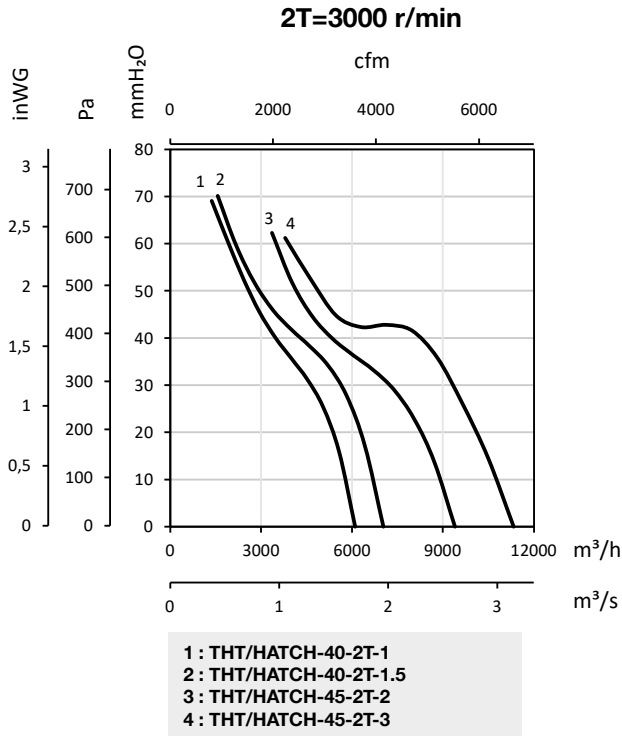

Characteristic curves

Q= Flow rate in m³/h, m³/s and cfm

Pe= Static pressure in mm H₂O, Pa and inwg

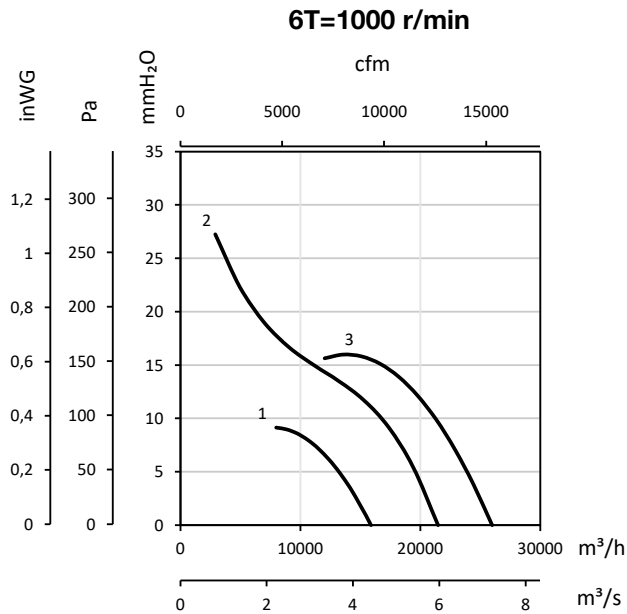

- 1 : THT/HATCH-63-6T-1
- 2 : THT/HATCH-80-6T-1.5
- 3 : THT/HATCH-80-6T-2

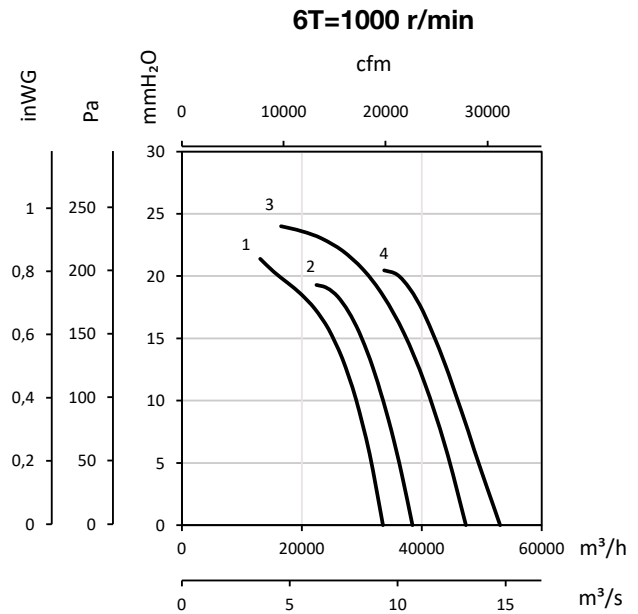

- 1 : THT/HATCH-90-6T-3
- 2 : THT/HATCH-90-6T-4
- 3 : THT/HATCH-100-6T-5.5
- 4 : THT/HATCH-100-6T-7.5

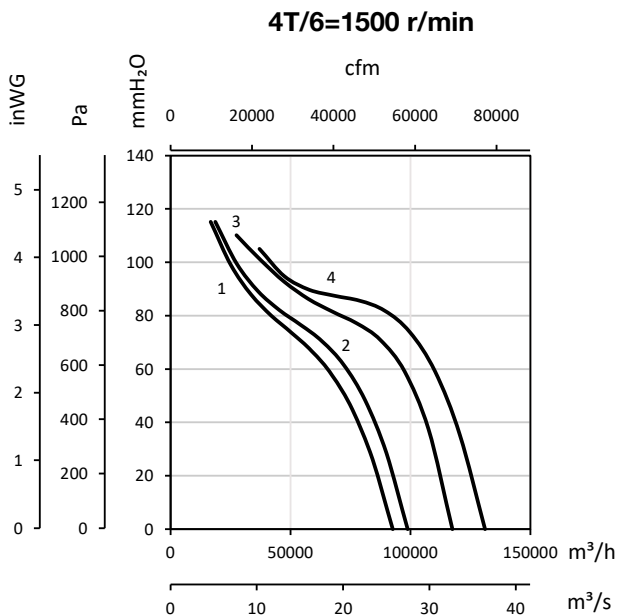

- 1 : THT/HATCH-125-4T/6-25
- 2 : THT/HATCH-125-4T/6-30
- 3 : THT/HATCH-125-4T/6-40
- 4 : THT/HATCH-125-4T/6-50

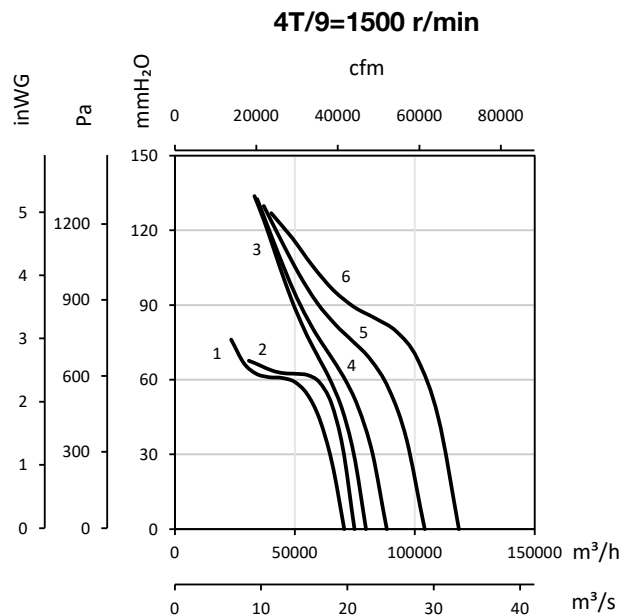

- 1 : THT/HATCH-100-4T/9-25
- 2 : THT/HATCH-100-4T/9-30
- 3 : THT/HATCH-125-4T/9-25
- 4 : THT/HATCH-125-4T/9-30
- 5 : THT/HATCH-125-4T/9-40
- 6 : THT/HATCH-125-4T/9-50

Characteristic curves

Q= Flow rate in m³/h, m³/s and cfm

Pe= Static pressure in mm H₂O, Pa and inwg

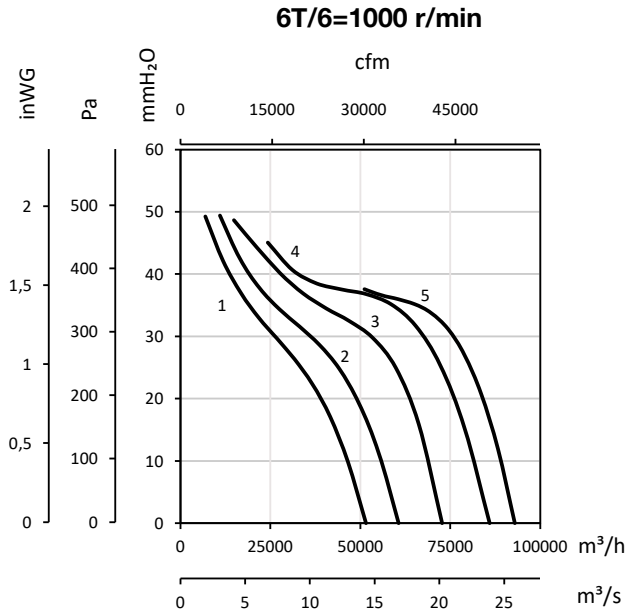

- 1 : THT/HATCH-125-6T/6-5.5
- 2 : THT/HATCH-125-6T/6-7.5
- 3 : THT/HATCH-125-6T/6-10
- 4 : THT/HATCH-125-6T/6-15
- 5 : THT/HATCH-125-6T/6-20

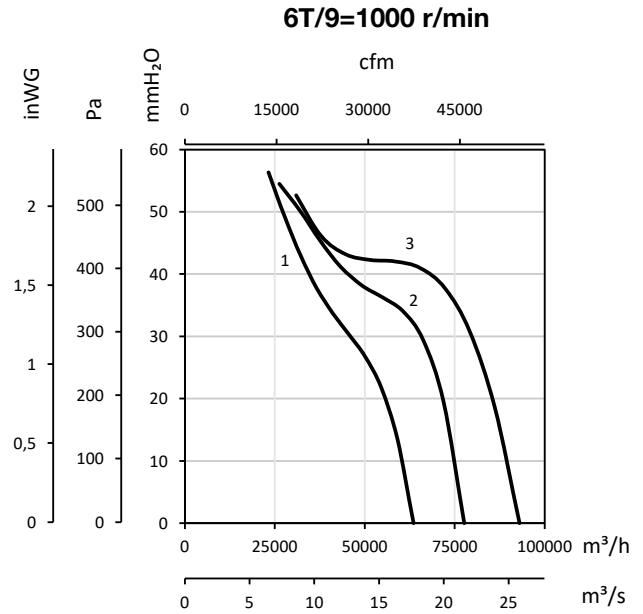

- 1 : THT/HATCH-125-6T/9-10
- 2 : THT/HATCH-125-6T/9-15
- 3 : THT/HATCH-125-6T/9-20

Accessories



CABLE BOX



VSD3/A-RFT
-VSD1/A-RFM

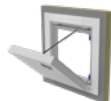

FRIDGE/FLAP

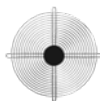

RT



PV



BAC



ACE ACE/400